



seed drills

NEUMASEM 699

NEUMASEM 799



**OPERATING MANUAL
MAINTENANCE
ADJUSTMENTS
SPARE PARTS**

please read carefully prior to operation

Seed Drills and Fertilizer Spreaders SOLA are produced in a factory particularly specialized in this kind of machines and they are guaranteed for the experience of the users.

They are machines based on state-of-the-art technology and are manufactured with recognized safety requirements for doing an excellent work with a minimal maintenance.

The purpose of this operating manual is to enable you to familiarise yourself with the working of your seed drill and to achieve your purposes.



Quality Certificate

Ref.: CN-811002

11^a Edition -05- 2010

It is forbidden the total and partial reproduction

We can modify the specifications without prior notice

1. INTRODUCTION.....	5
2. TECHNICAL SPECIFICATIONS.....	6
2.1. Technical data.....	6
2.2. Standard equipent.....	7
2.3. Optional equipmet.....	7
3. SAFETY INSTRUCTIONS.....	8
3.1. Safety symbols.....	8
3.2. Proper use.....	10
3.3. General arrangements.....	10
3.4. Loading and unloading.....	12
5. STARTING.....	14
5.1 Coupling the seed drill with cultivator.....	14
5.2 Coupling the seed drill without cultivator.....	15
5.3 Hydraulic system.....	16
5.4 Dosage.....	18
5.5 Microdosage.....	22
5.6 Setting the sowing depth, 799.....	22
5.7 Setting the sowing depth, 699.....	23
5.8 Distribution with mechanical fan.....	24
5.9 Distribution with hydraulic fan.....	25
5.10 Cultivator.....	26
5.11 Leveler.....	26
5.12 Harrow.....	27
5.13 Track markers.....	28
6. PLUS DRILL CONTROL.....	29
7. MAINTENANCE.....	48
8. DOSAGE TABLE.....	49
9. SPARE PARTS.....	52
9.1 Chassis.....	53
9.2 Arms bar 400,450,500.....	55
9.3 Arms 600.....	57
9.4 Arms bar of de discs.....	59
9.5 Arms bar 4 rows.....	63
9.6 Arms 799.....	65
9.7 Arms 699.....	67
9.8 Arms of de discs.....	69
9.9 Hopper.....	71
9.10 Transmission.....	73
9.11 Distribution-1.....	75
9.12 Distribution-2.....	77
9.13 Hidraulic fan.....	81
9.14Mechanical fan-1.....	83
9.15Mechanical fan-2.....	85
9.16Big mechanical fan.....	87
9.17Mechanical fan 3d.....	91
9.18Rear cultivator arm.....	93
9.19Rear cultivator.....	95
9.20Afloat cultivator.....	97
9.21flat leveler.....	99
9.22Leveler tines.....	101
9.23Track erasers.....	103
9.24Harrow.....	105
9.25Track markers.....	107
9.26Pre-emergence track markers.....	109
9.27Track markers 6 mts.....	111
9.28Track markers 6 mts/discs.....	113
9.29Finish.....	115
9.30Platform.....	117
9.31Stairs for retar cultivator.....	119
9.32Stairs for amrs bar of the discs.....	121
9.33Shut-off valves.....	123
9.34Optional equipment control monitors.....	125

Before you proceed to operate the seed drill, please read and observe these instructions. In this way, you will avoid accidents, reduce repair costs and downtimes and increase the reliability and service life of your seed drill.

This operating manual must be read and used by all persons who are required to work with the seed drill (including preparatory work, troubleshooting during operation, care), maintenance (inspection and technical servicing) and transporting.

Pay particular attention to the safety instructions. SOLÀ cannot assume any liability for damage or malfunctions caused by a failure to observe the instructions contained in this operating manual.

First of all, the manual will explain the Technical Specifications, the Safety Instructions, and some Essential Concepts for sowing. In the chapters PRIOR TO SOWING and MAINTENANCE, the manual will explain the basic instructions for working with the machine. This manual is finished with a Dosage Table with different types of seeds.



2. TECHNICAL SPECIFICATIONS NEUMASEM 699/799

2.1 TECHNICAL SPECIFICATIONS

TIPE AND ARMS	ARMS SEPARATION	WORKING WIDTH	HUPPER CAPACITY	WEIGHT	TYRE	TRANSPORT WIDTH
400/32	12,5 cm	4 m	1200 l	1450 kg	350/50-16	3 m
450/36	12,5 cm	4,5 m	1200 l	1570 kg	350/50-16	3 m
500/40	12,5 cm	5 m	1200 l	1680 kg	350/50-16	3 m
400/32	12,5 cm	4 m	1575 l	1500 kg	350/50-16	3 m
450/36	12,5 cm	4,5 m	1575 l	1620 kg	350/50-16	3 m
500/40	12,5 cm	5 m	1575 l	1730 kg	350/50-16	3 m
600/48	12,5 cm	6 m	1575 l	1850 kg	350/50-16	3 m

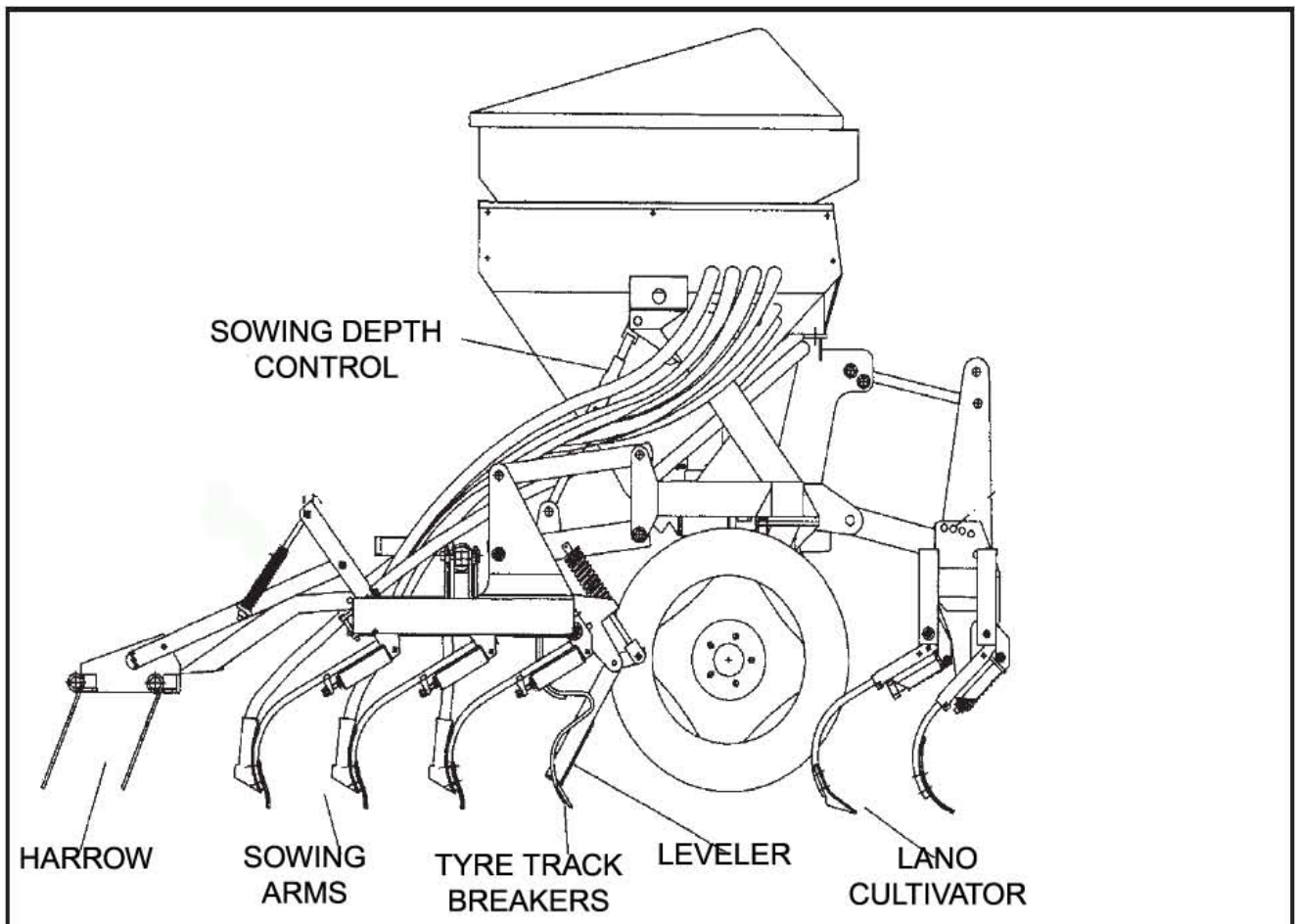

2.2 STANDARD EQUIPMENT

- Capacity hopper: 1200 l
- Sight of 825 l in the machines with big capacity hopper
- Selector sieve
- Hectare counter
- Electronic speed counter
- Seed level and distributor problems alarm
- Leveler
- Track erasers
- Hydraulic track markers
- Set of lights and working lamp
- Harrow
- Loading platform with access stairs
- Mechanical fan
- Hydraulic fan (type with cultivator).
- Arms with tooth furrow (699)
- Arms with coulter (799)
- Weighing machine, crank and grains counter

2.3 OPTIONAL EQUIPMENT

- Tramlining system
- Manuel shut-off valve
- Shut-off folding parts
- Total sowing shut-off
- Leveler
- Lateral wheels

3. SAFETY INSTRUCTIONS

3.1 SAFETY SYMBOLS

You will find, in this operating manual, three types of safety and danger symbols:



To facilitate operation with the seed drill



To avoid damages on the seed drill or in the optional equipments



This symbol warns of the risk of injury

On the machine, you will find the following symbols:

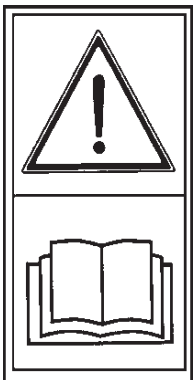

Please, read all safety instructions contained in this operation manual with care and also observe all warning signs attached to the seed drill.



If you are working under the machine, it is very important to assure it, to avoid its collapse. **Danger of serious lesions.**



Stay away of the tractor back part during the coupling operation, during the coupling manoeuvre. **Danger of serious lesions.**



Do not ride on the seed drill stairs when the machine is working. **Danger of serious lesions.**



Do not place under the sowing equipment or under swinging areas.
Danger of serious lesions.



Avoid fluid escaping under pressure.
Consult operating manual for service procedures.
Danger of serious lesions.

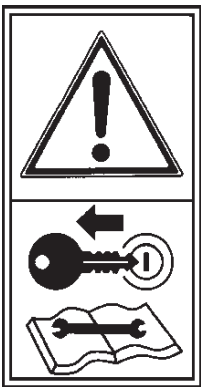

Stop the tractor engine and avoid its start during the maintenance or repairing works in the seed drill.
Consult operating manual.

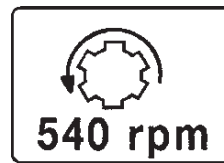

Direction and speed of the power point.
(only in the machines with mechanical fan)



Do not place under track markers.

Danger of serious lesions.



Couplint point to raise the machine.

3.2 PROPER USE

- Seed drill **NEUMASEM 699/799** has been produced for the agricultural works, specially for cereals sowing and the other grain seeds.
- SOLA cannot be held liable for any consequential damage resulting from incorrect use, metering or distribution.
- All relevant accident prevention regulations, as well as other generally acknowledged safety and road traffic regulations, must be observed.
- SOLA seed drills are intended for sowing. Any uses other than those will automatically exempt SOLA from its/his liability in respect on ensuing damages.

3.3 GENERAL SAFETY ARRANGEMENTS

- Before to start the machine, it is very important to read the operation safety and road safety.
- Road traffic regulations must be observed when towing the seed drill on roads.
- No persons may be allowed to ride on the seed drill during the work and during the transport.
- Before to bring into operation the machine, it is very important to know the parts and the elements.
- Be extremely careful when coupling and uncoupling the seed drill to tractor. This operation involves a high risk of injury.
- The transmission of the power point must be fitted with a protective equipment and in good conditions. Avoid the turns of the protector tube with the chaine. The side of the clutch will be fit in the seed drill.
- The transmission of the power point must be fitted when engine is stopped.
- Before to connect the power point, make sure that nobody is standing in dangerous proximity to the seed drill.

- Do not never abandon the seat drive during the work
- Do not place strange elements inside the hopper
- Before carrying out care or maintenance work, always de-pressurize the hydraulic system and switch off the p.t.o. shaft and the tractor engine.
- The hydraulic system generates extremely high pressures. All piping, hoses and connections must therefore be checked regularly for leakage and visible external damage. Useful life for these elements is not more than six years. You must change them after this time.
- When the seed drill is raised, the tractor front axle discharges. Verify that the charge is enough to avoid lodging danger. In this situation, verify direction and braking capacity.
- During the transport with the seed drill raised, block the descent control. Before descending of the tractor, place the machine on the ground and remove starting keys.
- Be extremely careful when working with the machine in raised position. Use support elements to avoid a possible descent of the machine.

3.4 LOADING AND UNLOADING INSTRUCTIONS

The trucks loading and unloading must be made with the help of a crane-bridge. To avoid the damages in the seed drill, we have to use a special hook, as you can observe in drawings 1 and 2. Haul down cables must fasten to the three-point linkage and to the fastening points prepared in the back arms bar.

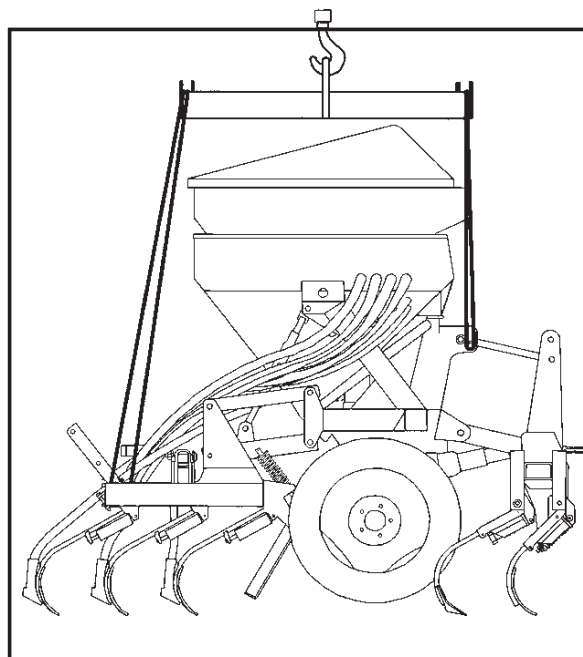
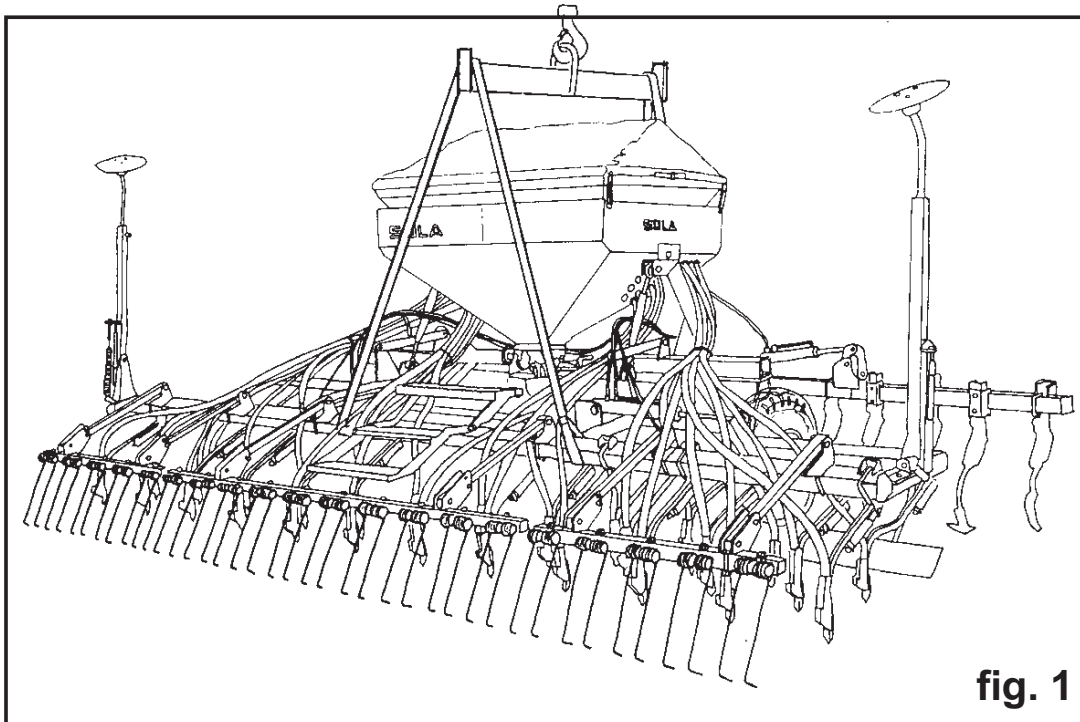

1

Sowing. Normal depth: from 2 to 4 cm

Thick stem, short rizhome, good freezing endurance.

Multiple sprouting, from 3 to 6 shoots and a lot of blades (from 6 to 10).

Big tuft of roots, 5 cms wide and 10-12 cms depth.

With less grains per square meters, we will obtain more ears.

2

Sowing. Between 5 and 6 cm

Thin stem, rizhome exposed to freezing.

Delayed and poor sprouting, one shoot (sometimes none), not many blades.

Medium tuft of roots, from 3 cm wide and 5 cms. depth.

We need more grains per square meter to obtain the same quantity of ears as in the first case.

3

Sowing. Very deep: from 8 to 10 cm

Very thin stem. No sprouting and a single blade

The grain reserves become depleted by forming a large rizhome,

Poor tuft of roots, just 1 cm wide and 3 depth.

We need twice the grains per square meter to obtain the same quantity of ears as in the first case.



In very cold areas, successive frosts may cause soil surface fluffing up, involving the risk of releasing the incipient plant roots and causing its death.

In these cases and to avoid this danger, it is recommendable to deeply more the seed or, if it is possible, to pass a roller in order to compact the land and to protect the seed.

5. STARTING

5.1 COUPLING THE SEED DRILL WITH CULTIVATOR

To reduce the seed drill width in order to transport the machine by truck, the cultivator is connected to the machine chassis with a links fitted in a special position. Also, the arms placed in the cultivator are wrongly placed of the working position de su posición de trabajo. When the machine is unloaded and BEFORE doing the folding essai, connecting rods and wrongly placed arms, will be placed in the correct position, as we can see in drawing 4. In a different way, the hopper could suffer damages during the folding operation.

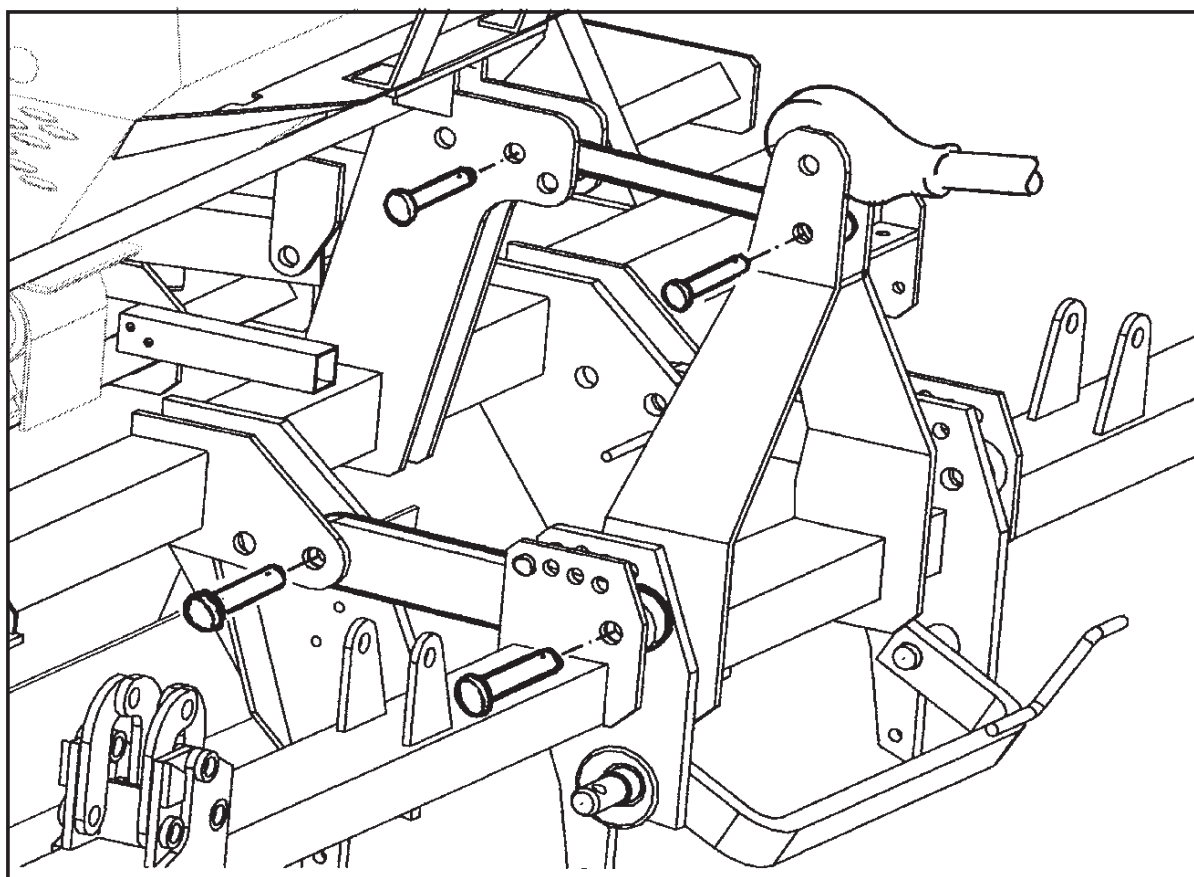
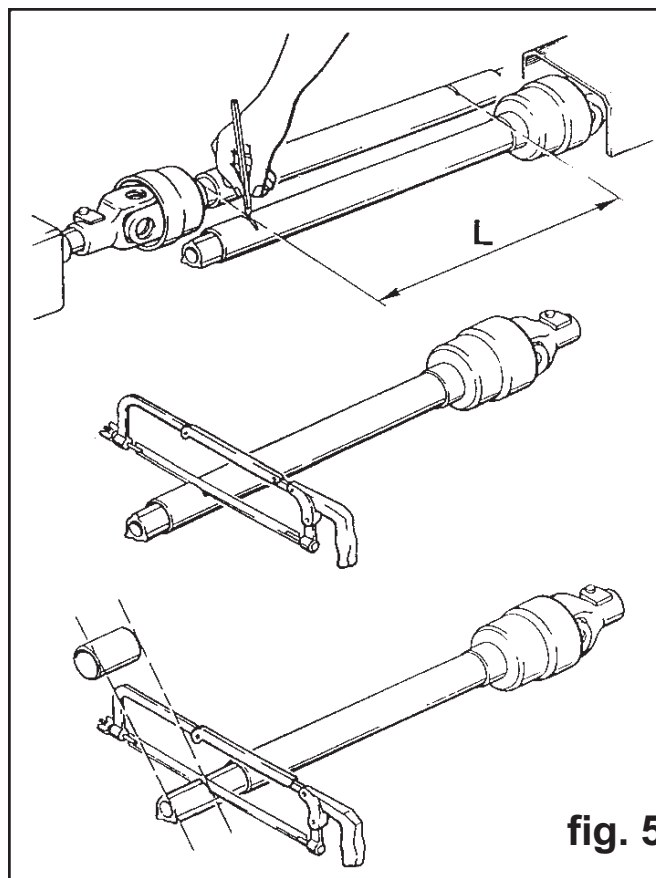

fig. 4

5.2 COUPLING SEED DRILL WITHOUT CULTIVATOR

Seed drills NEUMASEM are fitted for a fast coupling to the hydraulic and to the coupling bar.

Once the seed drill is coupled to the tractor, we have to adapt the joint shaft. Take to pieces and insert the end in the tractor power take-off and the other end in the seed drill. To calculate the lowest length of displacement "L" (drawing 5), lifting and descending the hydraulic lift. Cut to the correct length the metal and plastic parts, in the same size both pieces and place the transmission.



Verify that the transmission displacement was correct.



Make sure that the tractor engine and the p.t.o. shaft are switched off before proceeding to fit the universal joint shaft. Make sure that the protective tube can not rotate. Fix it with the chaine.



Disconnect the p.t.o. shaft to place the seed drill on the ground. In this way, you will avoid the transmission work with an excessive angle of divergence.. (maximum 35°).

Be extremely carefully actuate the tractor power take-off. ABRUPT STARTS COULD CAUSE IMPORTANT DAMAGES IN THE SEED DRILL.

5.3 HYDRAULIC SYSTEM

Flow regulator

It so the seed drill folding and unfolding realise carefully, we have two flow regulators. (drawing 6), one for each operation. They must be calibrated depending of the hydraulic flow given by the tractor. It is important and advisable to start with the regulator almost closed to avoid a too fast folding that could cause damages in the seed drill.



fig. 6



Make sure that nobody is standing in dangerous proximity to the seed drill.

Safety valve

Hydraulic system is fitted with a safety valve (drawing 7) to avoid the opening and closing of the cylinders while circulate by roads and ways. **Before desconecting the tractor hydraulic tubes, it is necessary to depressurize the. In this way, we will avoid the descending of the folding laterals during the time.** Before doing this operation, we have to switch-off the tractor.

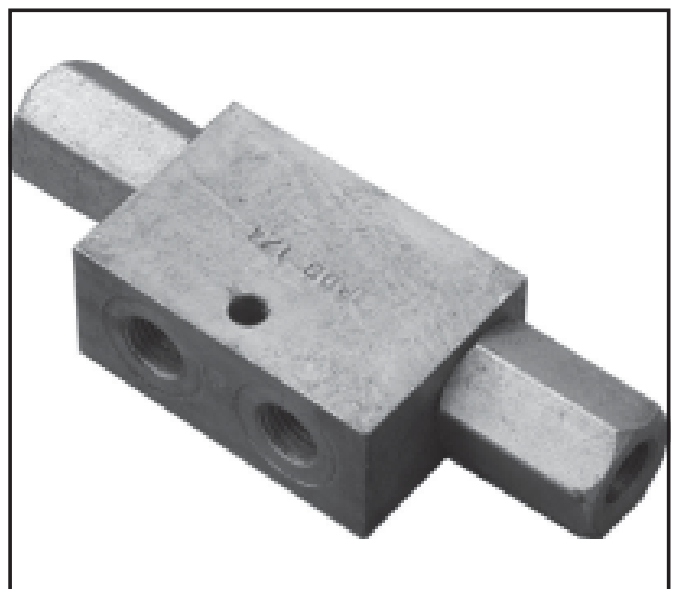

fig. 7

The machine is fitted with a mechanical safety pawl to secure the equipment during the transport of the machine. In drawing number 8 we can see the pawl in the safety position.

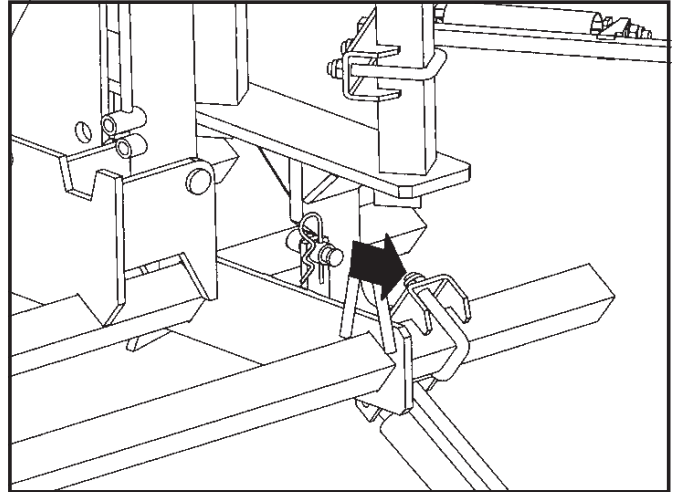

fig. 8



Before descending the equipment for working and after pressing to the system, be sure to take away mechanical pawls.

Parachute valves

Parachute valves are fitted on the connections of the sowing equipment cylinders. The valves mission es to avoid, in the case of breaking tubes, the equipment free fall.

These valves are regulated by the factory. Please, avoid their manipulation durant the maintenance and repairing works.

For your security, be sure that the valves are in the correct place before connecting the machine to the tractor and starting to work.



All piping, hoses and connections must be checked regularly. Spurting hydraulic oil can cause injuries and fires.

5.4 DOSAGE

We have two ways for doing dosage: for normal seed and for fine and small seed when sowing small quantities of seed.

For **normal seed** set the red change-over switch (n° 3, drawing 9) and the spring clip-butterfly valve (n° 8, drawing 9) to position N.



There is a risk of damaging the metering device when adjusting the seed rate to a lower setting. Do this only when the metering device is rotating or the seed hopper is empty.

fig. 9

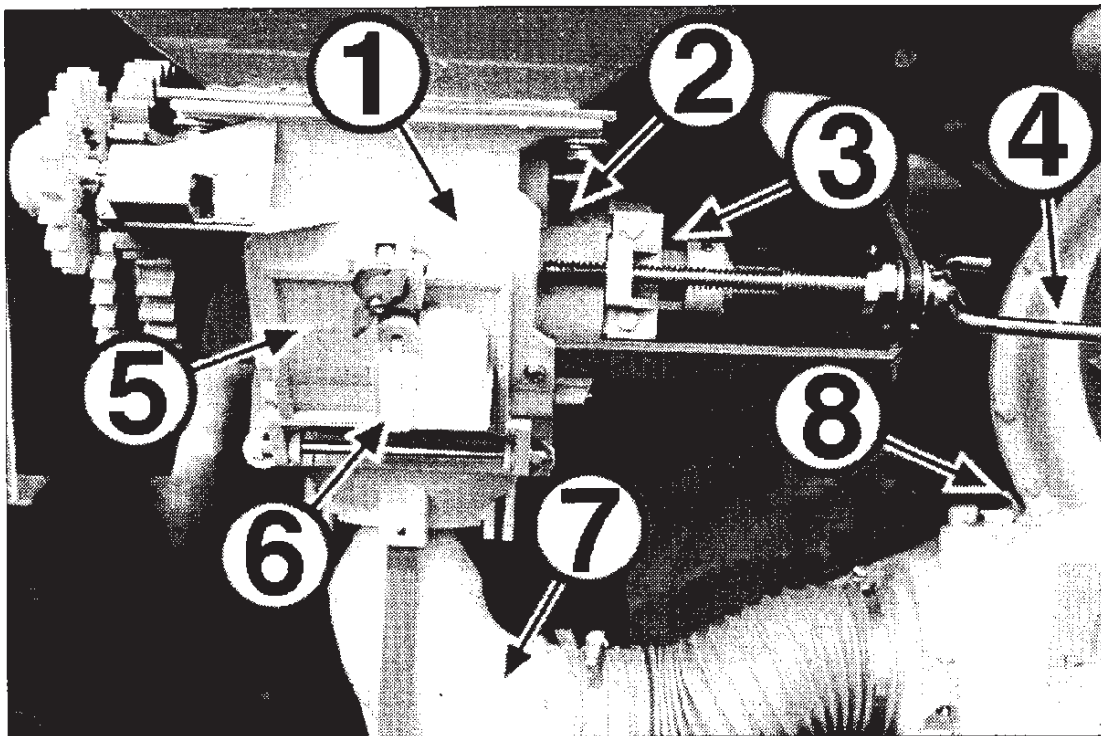

- 1 Housing
- 2 Metering scale
- 3 Red change-over switch
N = normal seed
F = fine or small seed
- 4 Spindle
- 5 Hopper trap-door

- 6 Rotary slide valve (not fitted on all machines)
- 7 Manifold
- 8 Spring clip-butterfly valve
N = normal seed
F = fine or small seed

For **fine seeds**, turn the spindle until the metering scale is in position 0. Turn the red change-over switch clockwise (n° 3, fig. 9) until it engages in the groove in the hexagonal shaft.

The letter F on the red change-over switch will no be visible. Now we can regulate from 0 to of the metering scale. The spring clip on the butterfly valve of the fan (n° 8, fig. 9) to position F.

Flow test

For doing the **flow test**, close the hopper trap-door and fill the hopper with seed. Open the venturi cones. Remove the manifold by unscrewing the wing nut (n° 7, figura 9). Place a bucket under the venturi cone outlet in order to collect the seed. Coloque

Attach the crank in the left wheel of the seed drill and turn, giving the turns number as follows:

TYPE	WHEELS 350/50-16
NEUMASEM 400/32	26,5
NEUMASEM 450/36	23,5
NEUMASEM 500/40	21
NEUMASEM 600/48	17,6

If necessary repeat the operation until you consider the seed has been calibrated.

Replace the cone venturi and the fan and secure by the wing nut.



To do the flow test make sure the seed drill is standing on firm, level ground. The tractor and the PTO shaft must be connected.

Dosage test

Between the test done and the flow spreaded by the machine, can exist some differences, owing to the few pressure in the wheels, irregularities on the ground, etc., we can do an experimental test.

With a tape measure, we can mark on the ground, the distance in meters indicated as the follows:

WORKING WIDTH	EXPERIMENTAL TEST METERS TO CROSSING
400	62,5
450	55,6
500	50,0
600	41,7

Then, we can cover the market distanc with the seed drill in working position. By means of a signal done in the wheel, we can count the wheel turns during the round.

In this way, we obtain the turns number to do the seed dosage test.

Doing the test with this number ot turns, we will obtain the kgs per hectare that the machine will spread.

Adjustment of the seed dose

With current use of high quality seed, it is not enough to set the weight that has to be distributed by the seed drill, since the final results of the harvest will depends on the number of plants that reach complete lripeness.

Each plant needs or requires its living space from which feeds on.

In this way, as poor could be a high plant density as a low.

To know or to decide the kgs per hectare to sowing, and to know the adequate dose, we must know the number of plants par square meter we are going to sow. Orientatively, the plants number recommended for wheat and barley in dry land is as follows:

AUTUMN:	early sowing,	200 plants per m ²
	late sowing,	265 plants per m ²
SPRING:	early sowing,	310 plants per m ²
	late sowing,	445 plants per m ²

Notice that, in spring, sprouting is always lower and, consequently, we need to increase the quantity to sow.



MAQUINARIA AGRÍCOLA SOLÀ, S.L., thinks that is very recommendable for the farmer, to seek advice about dosification in some technical sowing centers.



The seed dose, must be adjusted to each soil depending on its texture, fertilization level, dampness and sowing time, grain quality, germinative value...

Moreover, it must be took into account that the maximum germinative value is variable and depends on a lot of factors. Experimentally it can be established between 70% and 80%, that is equivalent to multiply the number of grains to sow by 1,43 or 1,25 respectively. Find as follows, a practical method to obtain the kgs per hectare we are going to sow starting from de plants per square meter we want to obtain.

- 1) To introduce the grains counter in the seed (drawing 10). Get out, pass the hand on in order to have only a grain for each hole (100 grains in total). Repeat the operation 10 times in order to have 1000 grains.

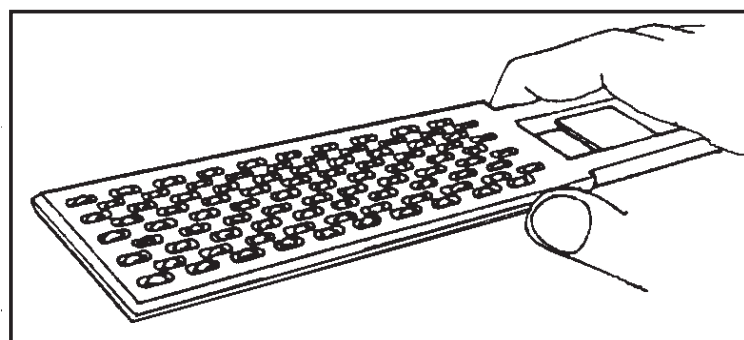

fig. 10

- 2) Weight the 1000 grains collected . Trought this operation, we will have the OPERATIF WEIGH.
- 3) Knowing the grains par square meter we are goint to sow, kgs per hectare we have to adjust in the dosage control are:

$$\text{kilos per hectare} = (\text{grains per m}^2 \times \text{OPERATIF WEIGHT}) / 100$$

5.5 MICROSAGE

The micrometering system serves as a means of metering fine seed and extremely small quantities of seed per hectare. The advantage of the micrometering system over the standard system when handling fine seed is that the cell is twice as wide for the same seed rate. This considerably enhances the self-cleaning properties of the cells.

Pull out the red gearwheel until it engages in position (n° 1, fig. 11). The micrometering system is now switched on. The settings are given in the calibration chart for fine seed (pages 33-36) with the micrometering system M.

- 1 Read gearwheel
- 2 Dispenser

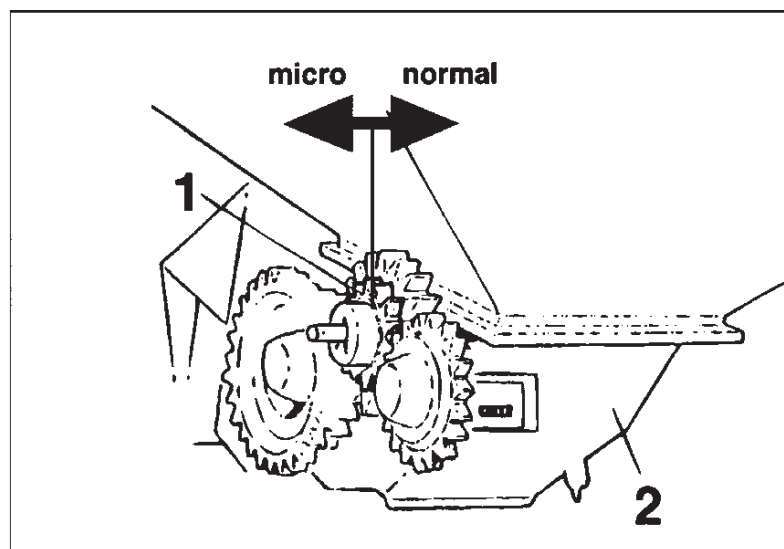

fig. 11



Check the cleaning brush before sowing with fine seed.

5.6 SETTING THE SOWING DEPTH NEUMASEM 799

The sowing depth can be adapted to the soil conditions by adjusting the coulter pressure.

Always, the seed drill will work in horizontal position.

Front and back coulters have to entered the ground in the same way.

Also, we can modify the sowing depth, adjusting the arms pressures individually by attaching to the coulter springs.

It exist, a spring kit for the smoothest grounds.

Another way to modify the sowing depth is attaching on the cultivator and the leveler: if the cultivator works deeper, the sowing arms works deeper, because they will find a free ground and the leveler will be able to drag more land.



In pneumatic machines, the air pressure, with the absence the record in the coulter, provoke that the seed depth in the rows was bigger than another conventional machine.

After some working minutes, verify that the sowing depth is correct.

5.7 SETTING THE SOWING DEPTH NEUMASEM 699

For setting the sowing depth in type 699 we have to modify the pressure of the springs of the arms. For this, we have to operate on three cranks adjusting the three sections that divide the arms equipment.

(drawing 12).

fig. 12

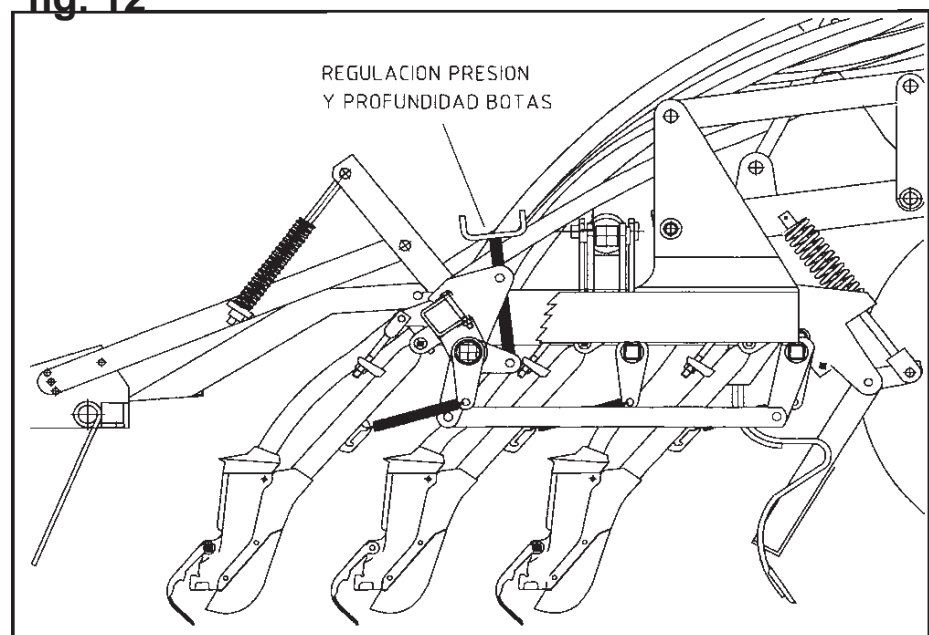

We have another possibility to adjust sowing depth. We can modify the sowing equipment height through the two tighteners that hold it to the chassis. With the sowing equipment hold on, sowing coulters have a penetration angle very big (nearly 90°) and they can bury the seed deeper. If we want to work in this position, the most advisable for the hard grounds, we will loosen the set nut of each arms in order to have that the sowing coulters descent for working better and for copying the unevenness of the terrain.

On the other hand, with the equipment in down position, coulters work with an angle of small penetration and the seed depth is smallest. In this case, we must tighten the adjustment nuts of each descended arm. To lift the seed drill, the arms do not descend too and the pressure springs will be able to go out of their grooves.

5.8 DISTRIBUTION WITH MECHANICAL FAN

To guarantee the seed supply to the sowing coulters it is necessary that the fan turns between 4200 and 4500 r.p.m, for that we must take the p.t.o. at the outlet with 1000 r.p.m.

With less speed, some seeds could stay in the conductor pipes.

Also, we will take precaution to turn the fan to the operating speed before turning the transmission wheel.

To raise the machine, we will not reduce the operation speed until the wheel do not touch the ground.

If we trail the seed drill along the ground with air fan switched-off, the seed coming from distributor will block the manifold that feed the venturi cone. In the case it happens, replace the manifold and collect the seed before starting the normal operation with the seed drill.



The turn of the transmission wheel without fan to full operation can cause the blocked of the manifold tubes.

5.9 DISTRIBUTION WITH HYDRAULIC FAN

Type of machine	Hydraulic motor		Oil supply		
	absorption capacity (cm ³)	speed (rpm)	minimum feed line pressure (bar)	maximum return line pressure (bar)	flow rate (l/min)
400	8	4200	130	10	10
450/500/600	8	4500	160	10	44

Connection

Connect the fast plug of the fan small pipe to a pressureless line of the tractor. Connect the pipe of 1/2" with the big fast plug, to a return line without pressure.



The maximum permissible return line pressure is 15 bar. Too high pressure will force the shaft seal out of its seating.

Settings

Adjust the fan speed to a 4200 r.p.m. or to 4500 r.p.m. as the upper table.



If you find that the oil becomes over heated, either because the delivery rate is excessively high or the oil reserve is too small, it could be necessary to fit an additional oil reservoir.



If it is not possible to obtain the required flow rate for normal operation, an additional hydraulic circuit must be installed. (hydraulic pump, pressure relief valve, directional valve, oil cooler, and possibly and additional reservoir). So as not to increase the pressure in the pressure line unnecessary verify hydraulic lines. Consult your manufacturer.

5.10 CULTIVATOR

The cultivator work has to be superficial but enough to erase the tractor marks. For achieving this result it is possible to adjust the arms located behind the wheels tractor with a different depth than the others.

The cultivator has 4 points to adjust in 4 different ways and it is afloat, that is, it has lateral movement and it is independent of the seed drill. It is possible to lift it with the tractor elevator while the seed drill remains on the ground.

5.11 LEVELER

The leveler work is essential to obtain a sowing of regular depth. We can adjust the leveler operating on four screws (drawing 13) to modify height and pressure of the leveler three sections.

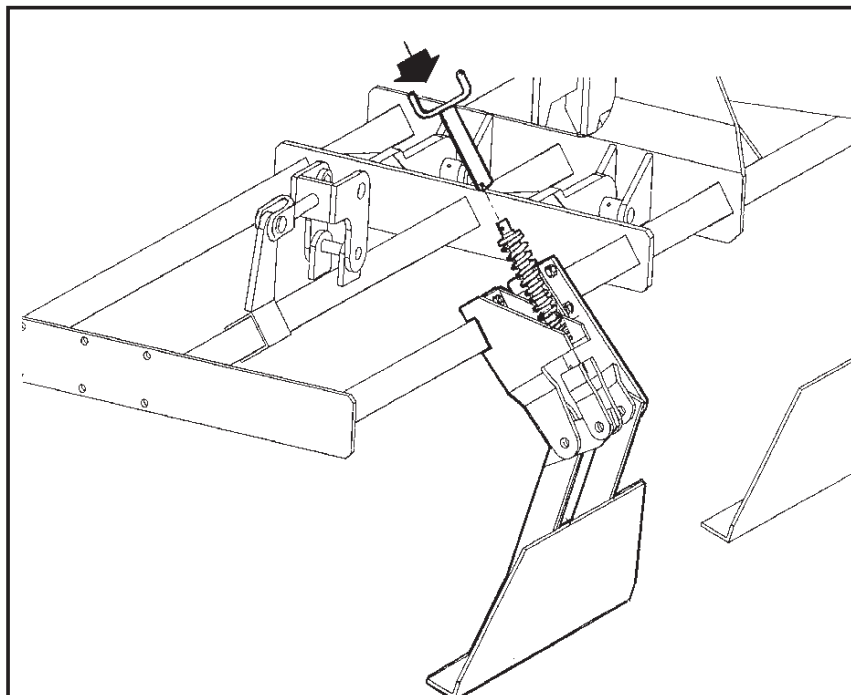

fig. 13

The leveler must trail the land but avoiding that the land running over the plate. To erase the seed drill marks, we can fit the track erasers. We have to adjust them.

5.12 HARROW

The harrow has different positions for working on different ground types. We can adjust:

- 1- Height: tighten the lower bolt (1, drawing 14).
- 2- Pressure: tighten the upper bolt of the brace rod (2, drawing 14).
- 3- Positions: modifying the screws position that hold the harrow to the arms (3, drawing 14).

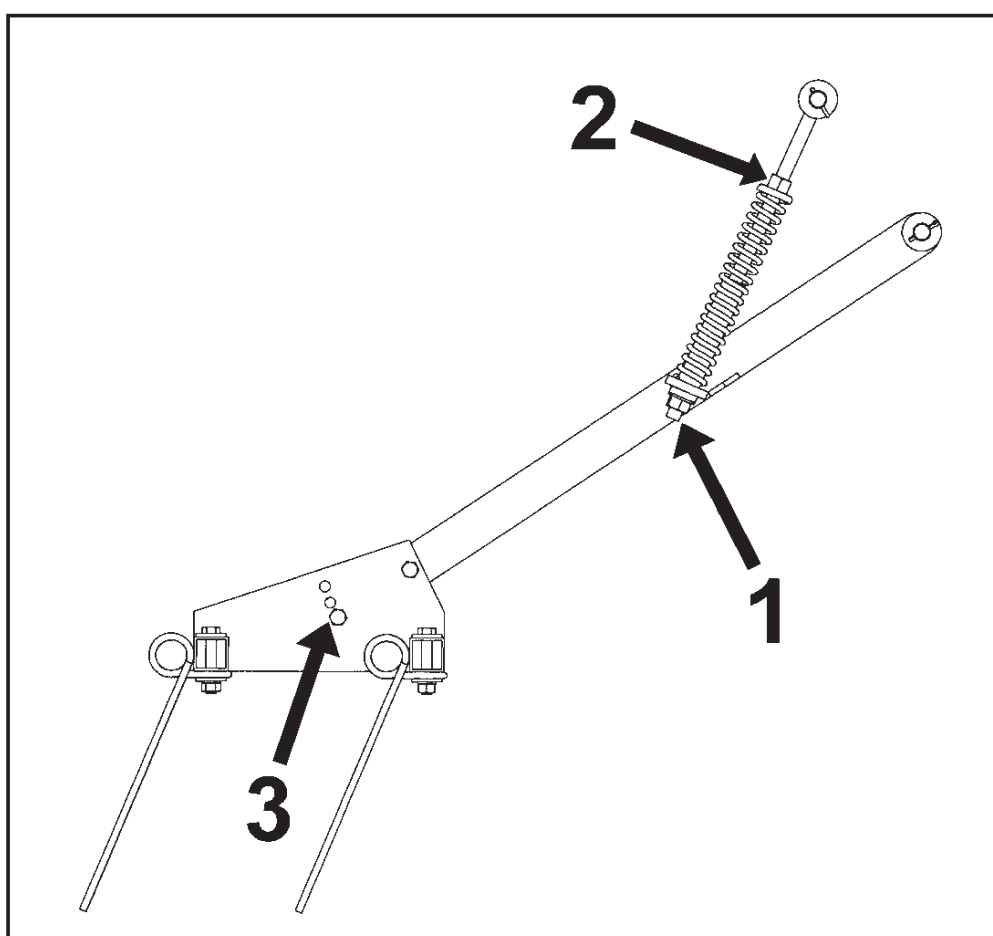
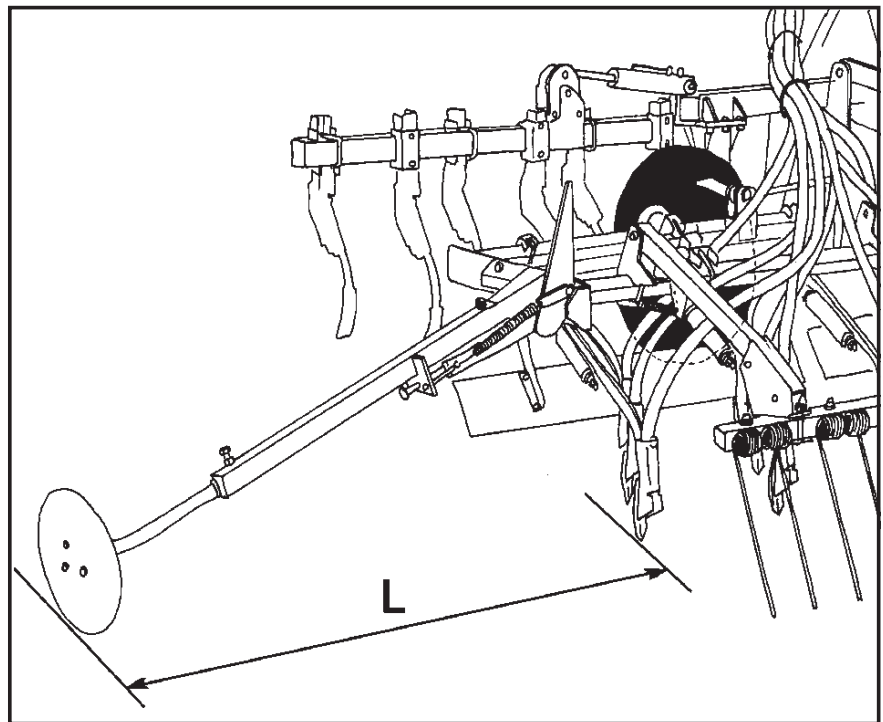

fig. 14

5.13 HYDRAULIC TRACK MARKERS

Track markers are fitted in the laterals of the folding equipment. The right marker is fitted on the short support and the left marker on the long support. Their operation is hydraulic and we have to connect them to two different connectors for working in an indistinctly way. It is very important to fold the track markers and fix them with the bow pin before folding the machine for transporting.

The track markers arms are extending. We can adjust them in length and we can position the discs on the correct penetration inclination. The spring allows to adjust the disc pressure on the ground. The length of the track markers is calculated as follows:



$$L = \frac{\text{working width seed drill - track gauge wheels tractor} + \text{width of the row}}{2}$$

NOTE: Sizes in cms



It is not advisable use to much the spring pressure, to avoid seriously damages.



The pressure oil can penetrate in the skin and can cause injuries and fires. Be extremely careful with the hydraulic connections and tubes.



No persons may be allowed to stand within the working area.

6. PLUS DRILL CONTROL

6.1 Overview

The *Sola Neumasem Drill Control* monitors several functions of the seed drill, sets the seeding width, and controls the tramlining function of both conventional and pneumatic type seed drills. The instrument has an illuminated 4-digit display with 6 display functions and alarm functions for forward speed, fan rpm, seed distribution shaft rpm and hopper level.

The speed and area functions are displayed in metric units.

The instrument indicates;

- Forward Speed (plus low speed alarm)
- Part Area and Total Area worked
- The current bout number and tramline bouts for the selected tramlining sequence.
- Fan rpm (plus low/high speed alarm)
- Seed Distribution Shaft rpm (plus low speed alarm)
- Hopper level low (plus alarm)

There are two memory registers (Total 1 and Total 2) to record area worked. The area is accumulated to both memory registers. Area totals and all calibration data are automatically stored in memory when the instrument is powered off.

The instrument also indicates whether seeding at part width or full width, or that the micro-metering ratio (for small seed) is in effect.

Normal Display Mode

The instrument has a normal display mode displaying the work functions. Select a channel by pressing the  button once or more.

When the drill is moving, the selected channel is displayed for 10 seconds before defaulting back to the tramline display ( channel).

Programming Modes

There are 2 programming modes with various calibration factors and default settings.

Many of these settings are made on installation and do not normally need to be changed unless the instrument is switched onto a different drill. These settings are appended to the back of this manual. The operator does not normally need to refer to them.

6.2 The Control Switches

There are five switches on the front panel used individually or in combination to select, programme, or reset a function.

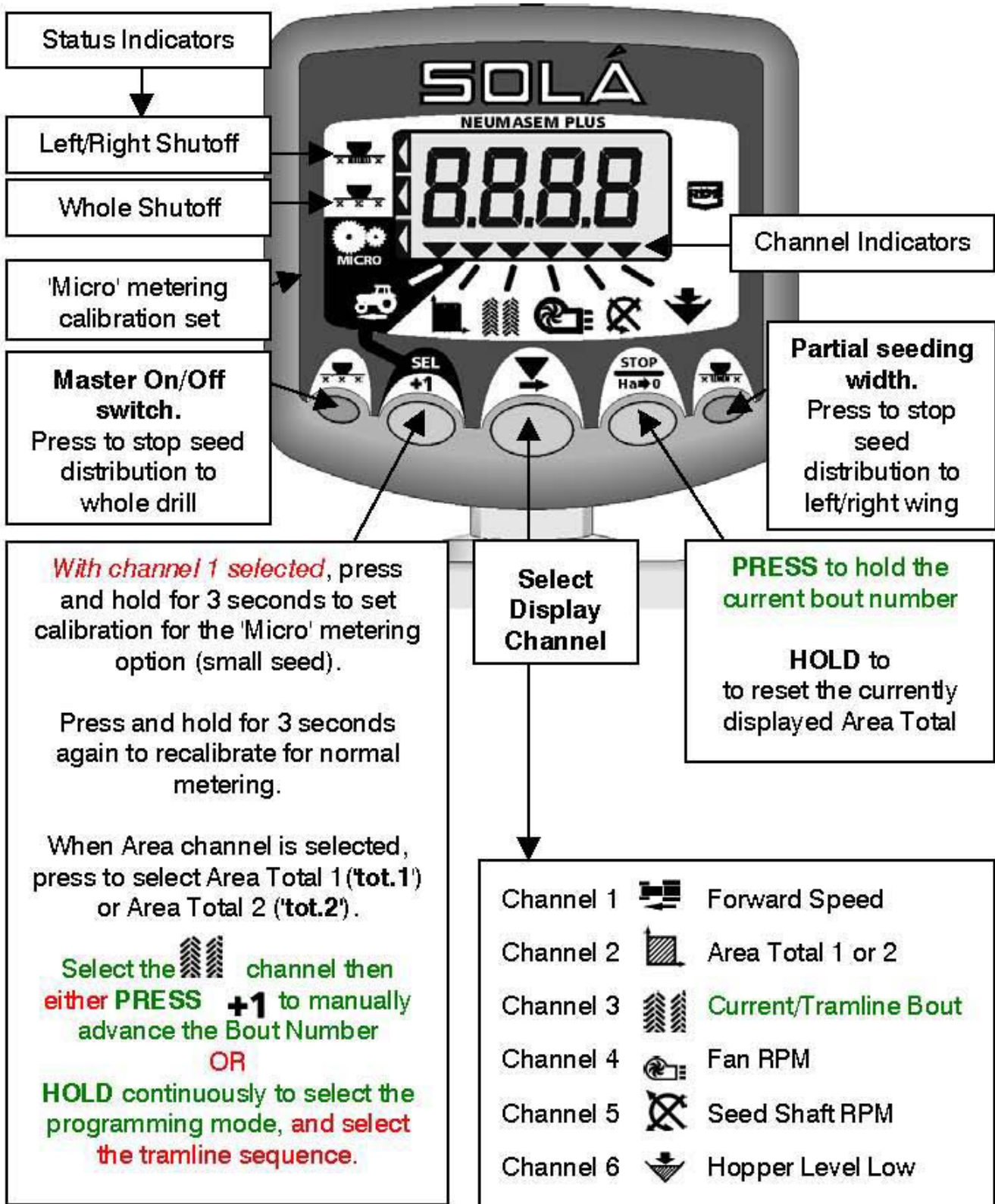

6.3 Forward Speed

Display Forward Speed



Forward Speed displays for 10 seconds before returning to the tramline display.

If an alarm condition occurs, the display will default to the appropriate channel, the buzzer will sound 5 beeps, and the display will remain flashing on that channel until either,

- (i) the alarm condition is rectified.
- (ii) the forward speed drops below 2km/h.
- (iii) another channel is selected and the alarm ignored.





Figure 1: Display Forward Speed

Forward Speed Alarm

If you stop while the drill is in work, then the instrument will beep twice, and the display will alternate between '0.0' and 'ALAR'

This continues until the speed is increased above the 2.0 km/hr threshold.

Disable Forward Speed Alarm

1. Press and hold  whilst switching on the instrument to enter programme mode 2. The display should show '1' indicating the alarm is enabled.
2. Press  to set '0' and disable the alarm.
3. Switch the instrument off and on again to resume normal operating mode.

FORWARD SPEED C1

Select the channel with the central button. Under 2.6 km/h the alarm rings. You can deactivate this alarm by entering in programme 2.

Speed sensor calibration

Enter a calibration factor in programme 2, following this panel:

MODEL	400	450	500	600
CALIBRATION FACTOR	1.818	1.574	1.449	1.258

1. Select the speed channel. (C1)
2. Press "SEL" to enter in rate 1. Keep pressing and press the central button (v) to change the digit to modify.
3. Keep the central button pressed for some seconds to modify the digit's moving value. Leave the value on the screen.
4. Stop pressing the buttons and the monitor will return to normal position.

The S.S.F. is normally calculated automatically via the "Autocal" function.

'Autocal'

For maximum accuracy, perform an auto-calibration in field conditions.

NOTE: The seed shaft gear ratio must be set for normal seed i.e. not set for 'micro' metering. If the gearing is set to the 'micro' ratio, speed calibration will be incorrect resulting in incorrect forward speed display and area accumulation when set at the normal metering ratio.



1. Set two markers at 100 metres apart (328 feet). Choose a convenient reference point on the tractor/implement and position this point opposite the first marker.
2. Select the  channel.
3. HOLD  until the existing calibration factor is displayed.
4. Continue holding this button and press 
The display flashes 'Auto' ready for calibration.



Figure 2: Start 'Autocal'

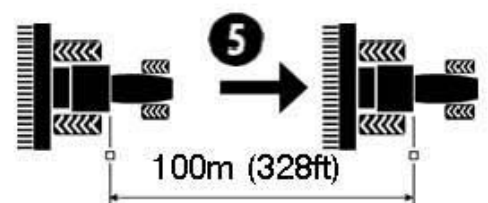



Figure 3: 'Autocal' distance

5. Drive the vehicle until the chosen reference point on the tractor/implement is opposite the second marker.

The instrument counts and displays the sensor pulses received over the distance travelled.

6. Press the  button to complete the Autocal routine (fig. 4).

The calibration factor is automatically calculated and stored in memory.



Figure 4: Stop 'Autocal'

6.4 Area Total / Implement Width



The area is derived from the forward speed and the programmed implement width and is accumulated to whichever total is selected on the display – total 1 or total 2.

Area will only accumulate while the drill is in work, i.e. forward speed is being registered, and is automatically calculated based on the seeding width selected.

The two separate area totals can be independently reset to zero.

Display Area Total



1. Select the  channel.
2. Press  to cycle between the two area totals.

The display will then show 'tot.1' or 'tot.2' before displaying the area accumulated since that total was last reset.

Area total displays for 10 seconds before returning to the **tramline** display.

Reset Totals



1. Select the  channel.
2. Press  to cycle between the two area totals.
3. Hold  for 5 seconds to zero that total.



Figure 5: Display Area Total



Figure 6: Select Total 1 or Total 2









Figure 7: Reset Total

View/Set Implement Width

In order for the instrument to accumulate area correctly, the implement working width must be programmed. The units are in metres.

View/Set Left/Right Wing Width

1. Select the  channel.
2. Press  to select left/right wing shutoff as shown by the left top indicator (fig. 8).
3. HOLD  to enter programme mode 1.
After 5 seconds the current wing width is displayed with the first digit flashing.
4. To change the value, continue holding the button and...
5. PRESS  to select the digit or decimal point to change.
6. HOLD  to change the selected digit (or move the decimal point).
7. RELEASE  to select the next digit and repeat as above, otherwise simply release both buttons. The instrument will then return to the normal display mode.

View/Set Full Width

As above except first press  to select full width shutoff as shown by the left middle indicator (fig. 10).



Figure 8: View Wing Width



Figure 9: Set Wing Width



Figure 10: Set Full Width

6.5 Tramlining

The display defaults to the  channel after 10 seconds (unless the Area Total was selected).

There are five systems of tramlining - symmetric, asymmetric left, asymmetric right, 10 bout and 18 bout. The tramline bout is programmable from 1 to 15 in symmetric, asymmetric left and asymmetric right sequences.

Selection of asymmetric tramlining is denoted by a decimal point on the display between the current bout number on the left and the tramline bout number on the right. Left or right asymmetric tramlining is selected in the programming mode.

NOTE: There is an option in the programme mode to disable the tramline function altogether.

Manually advance the bout number

Press  to advance the current bout number by 1.

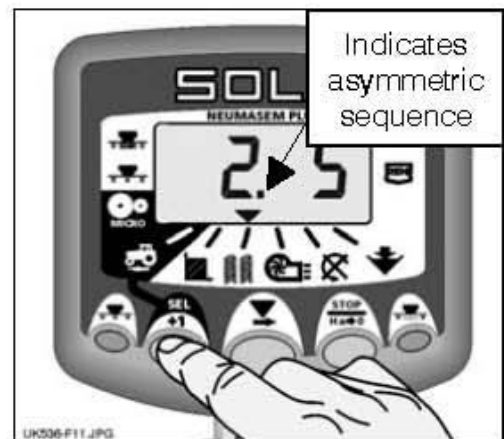



Figure 11: Advance bout number

Hold the bout number

Press  to 'hold' the current bout when the drill goes out of work.

The display will flash 'StOP'.

Press  again to resume the normal bout sequence.

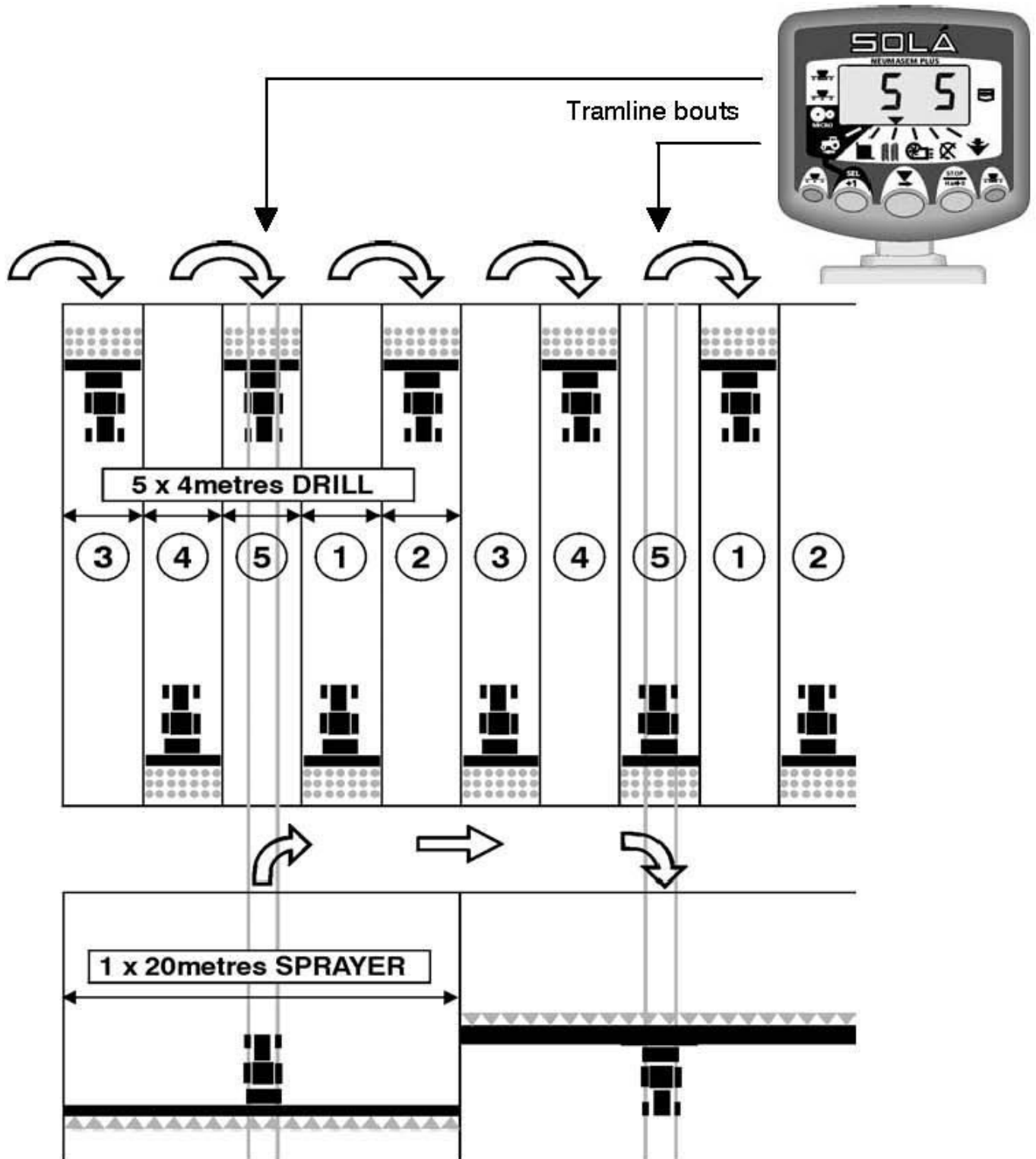

Figure 12: Hold bout number

Symmetric Tramlining Sequence

2+2 seed spouts are closed during the tramline bout only.

The instrument will beep once at the beginning of the tramline bout, and the display will continue flashing for the duration of the bout.



Asymmetric Left Tramlining Sequence

Two seed spouts are closed on the **left hand side** of the drill on the tramline bouts.

The instrument will beep once at the beginning of each tramline bout, and the display will continue flashing for the duration of the bout.

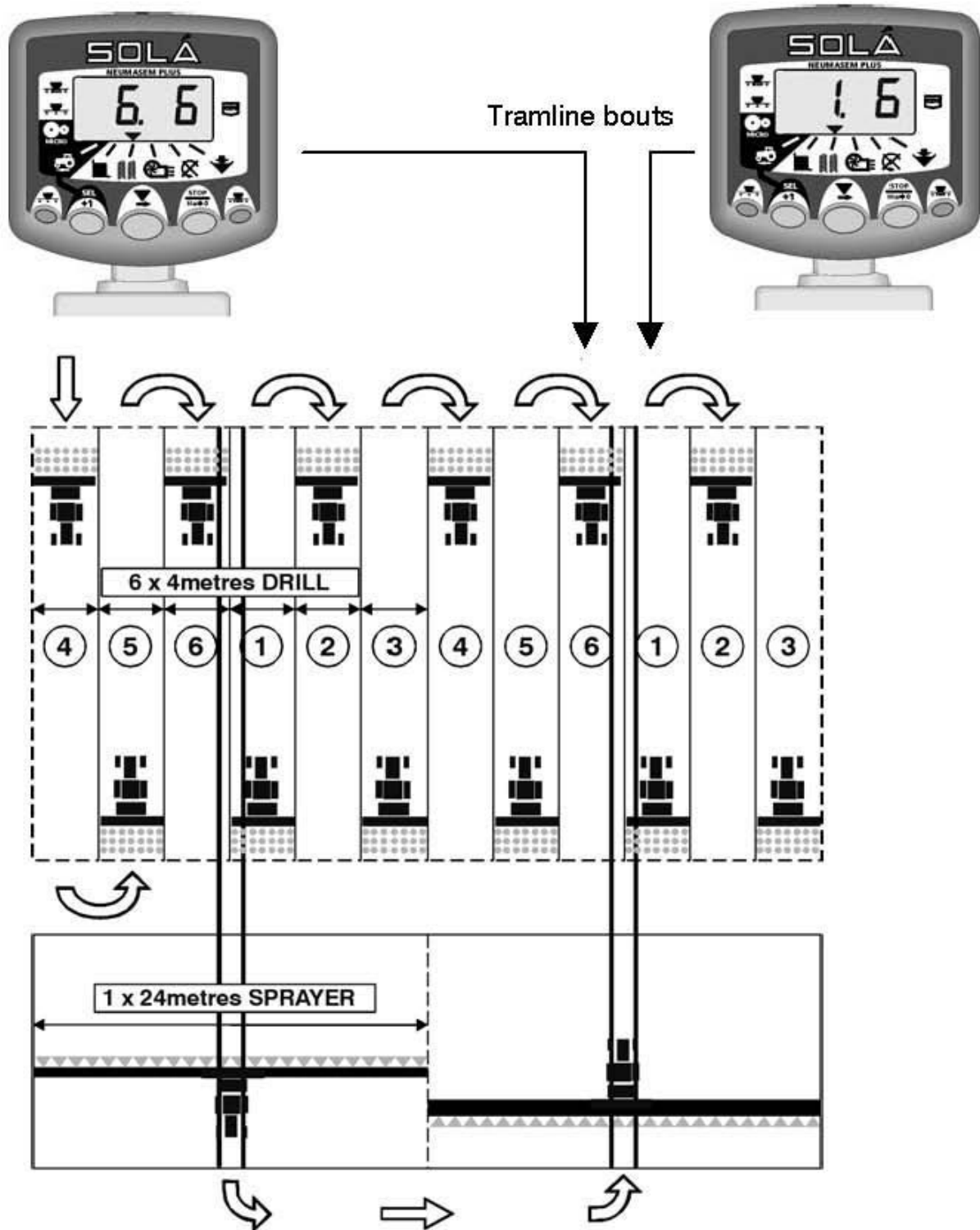

Asymmetric Right Tramlining Sequence

Two seed spouts are closed on the **right hand side** of the drill on the tramline bouts.

The instrument will beep once at the beginning of each tramline bout, and the display will continue flashing for the duration of the bout.

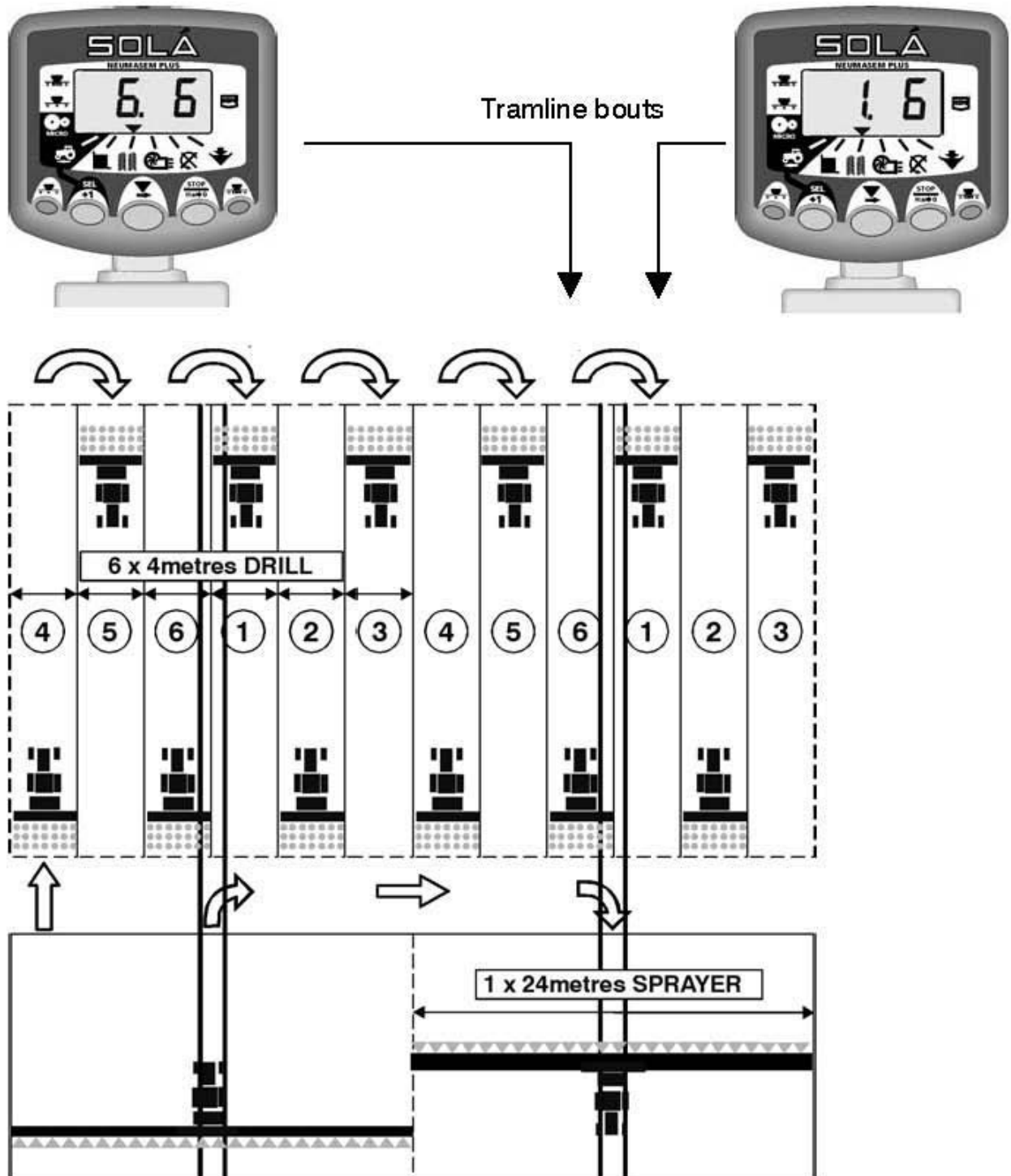

10-Bout Tramlining Sequence

For use with 4 metre drill/10 metre sprayer, or 8 metre drill/20 metre sprayer combinations. (2 x 2 left hand seed spouts are closed on bouts 4 and 7, and 2 x 2 right hand seed spouts closed on bouts 2 and 9). Starting on bout 1 requires turning **RIGHT** at the end of the first bout.

NOTE: To turn LEFT at the end of the first bout, advance the bout number to 6 before commencing drilling.

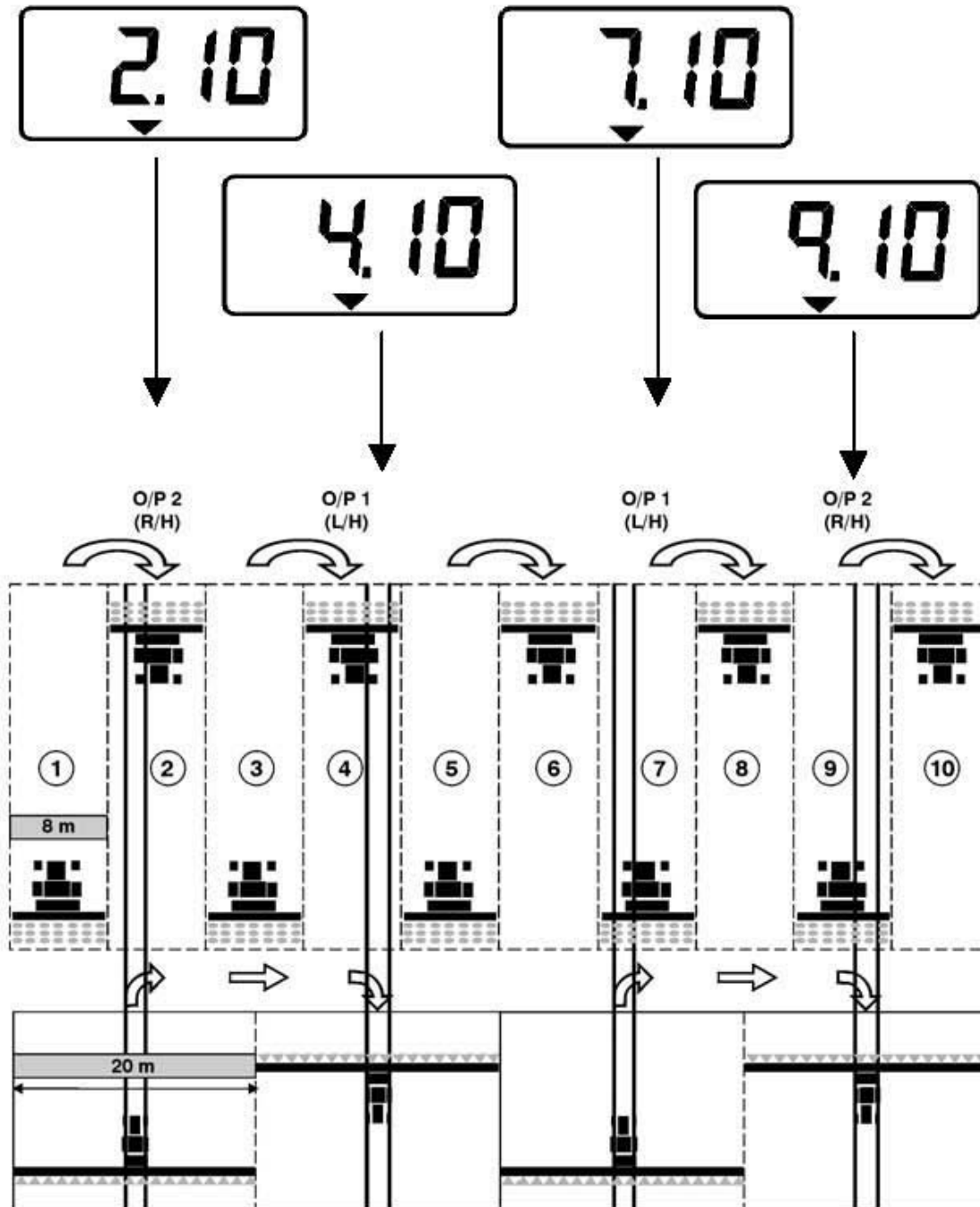

/10BOUT.CDR

18-Bout Tramlining Sequence

For use with a 4 metre drill and an 18 metre sprayer. (2 x 2 left hand seed spouts are closed on bouts 3 and 16, and 2 x 2 right hand seed spouts closed on bouts 7 and 12). Starting on bout 1 requires turning **RIGHT** at the end of the first bout.

NOTE: To turn **LEFT** at the end of the first bout, advance the bout number to 10 before commencing drilling.

The instrument will beep once at the beginning of each tramline bout and the display will flash for the duration of the tramline bout.

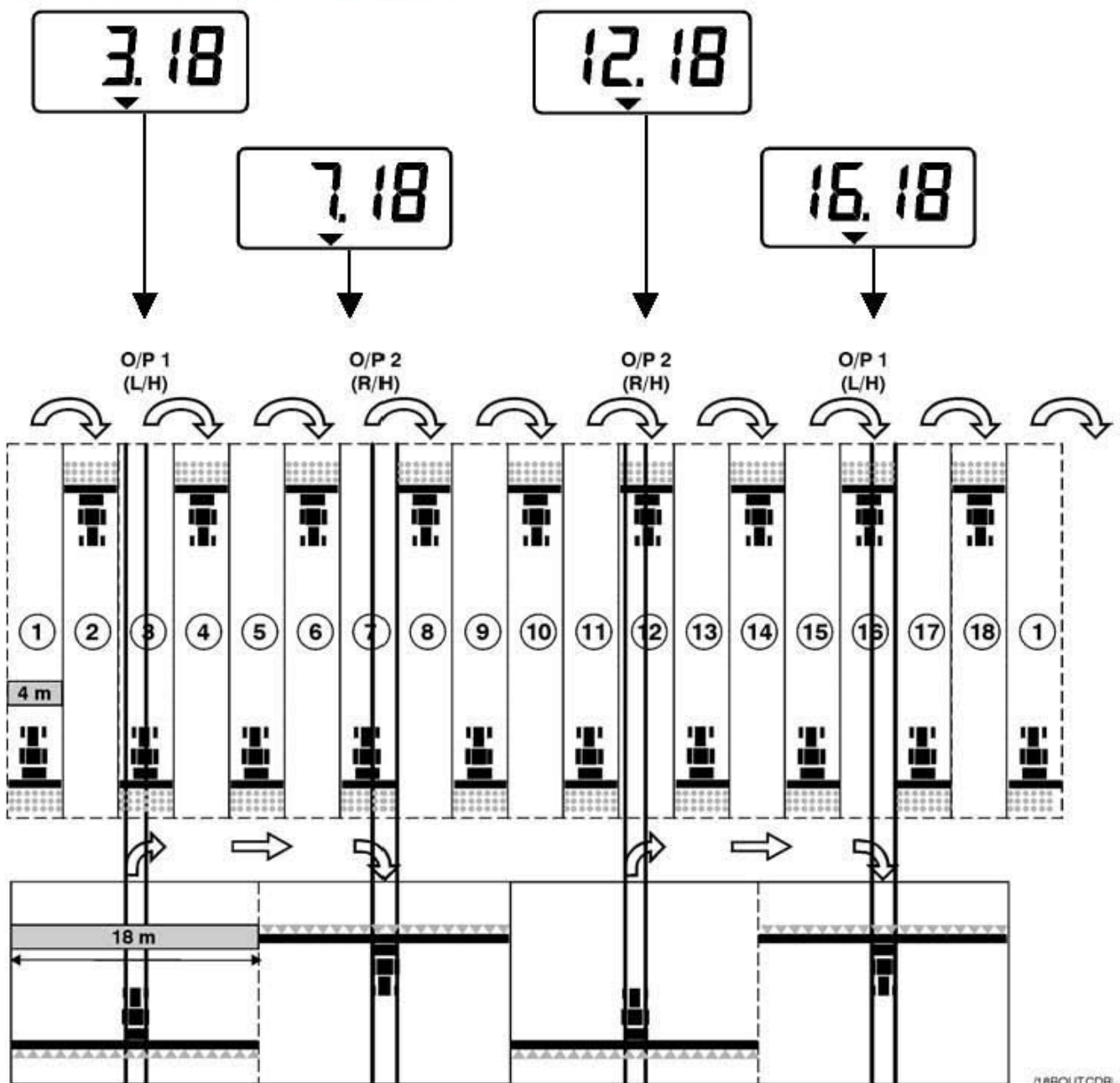

/18BOUT.GDR

Selecting the Tramline Sequence





1. Select the  channel.
2. Hold  to enter programme mode 1.
After 5 seconds the first two digits flash, indicating the tramline sequence currently set:-
'SY' = Symmetric
'AL' = Asymmetric Left
'Ar' = Asymmetric Right
'AS' = Special Asymmetric sequences e.g. 10 bout and 18 bout.
3. Continue holding the  button and press and HOLD the  button to select the required sequence.



Figure 13: Tramline Sequence

Setting the Tramline Bout



4. PRESS and RELEASE the  button to toggle between the tramline sequence and tramline bout number display.
The 3rd and 4th digits flash indicating the tramline bout number currently set.
5. PRESS and HOLD the  button to cycle the tramline bout from 1 to 15.
NOTE: If either asymmetric left ('AL') or asymmetric right ('Ar') sequences are selected, the tramline output is also switched on for the bout following the target bout (i.e. bout 1).
If the special asymmetric sequence ('AS') is selected, the only options for the tramline bout number are 10 and 18.



Figure 14: Tramline Bout Number

6.6 Fan Speed / Speed Alarms

Display Fan Speed



Select the  channel.

Fan Speed displays for 10 seconds before returning to the **tramline** display.

Fan Speed Alarms

There is a programmable **low**-speed alarm and a **non-programmable high** speed alarm. An alarm condition causes the instrument to default to the fan speed channel, sound 5 beeps and flash the actual fan speed. The audible alarm will continue to sound every 30 seconds until the alarm condition is resolved.

NOTE: The alarm is temporarily inhibited if another channel is selected, or if the forward speed is less than 2 km/hr.

Thresholds: Low speed = 2700 rpm (default), High speed = 5000 rpm

Set Low Fan Speed Alarm





1. Select the  channel.
2. Hold  to enter programme mode 1.
The alarm threshold is displayed after 5 seconds. Continue holding the button and...
3. PRESS  to select the digit or decimal point



Figure 15: Display Fan Speed



Figure 16: Low speed alarm threshold

4. HOLD  to change the selected digit (or move the decimal point).
5. RELEASE  to select the next digit and repeat as above, otherwise simply release both buttons. The instrument will then return to the normal display mode.

High Fan Speed Alarm

The high speed alarm is set at 5000 rpm and is not programmable.

6.7 Seed Distribution Shaft Speed

Display Shaft Speed



Select the  channel.

Shaft Speed displays for 10 seconds before returning to the **tramline** display.





Distribution Shaft Speed Alarm

The default alarm setting is 0 rpm. When set >0 , and the seed shaft rpm goes below the threshold or stops, the instrument will sound 5 beeps and will default to the  channel from the current channel selected.

The audible alarm will continue to sound every 30 seconds until the alarm condition is resolved.

NOTE: The alarm is temporarily inhibited if another channel is selected, or if the forward speed is less than 2 km/hr.

Set Alarm Speed for Distribution Shaft

1. Select the  channel.
2. Hold  to enter programme mode 1.
The alarm threshold is displayed after 5 seconds. Continue holding the button and...
3. PRESS  to select the digit to change.
4. HOLD  to change the selected digit.
5. RELEASE  to select the next digit and repeat as above, otherwise simply release both buttons. The instrument will then return to the normal display mode.

NOTE: Setting '0' disables the alarm function.



Figure 17: Distribution Shaft speed

6.8 Hopper Level





This display is left blank if the alarm function is disabled in programme mode 1.

When the alarm is enabled, when the seed level drops below the sensor fitted in the side of the hopper, the instrument defaults to this channel and sounds 5 beeps



Figure 18: Hopper Low Alarm

Enable / Disable Hopper Level Alarm

1. Select the  channel.
2. Hold  to enter programme mode 1. Continue holding the button and...
3. PRESS  to select 0 (Off) / 1 (On).

The display will stay blank on this channel when the alarm is disabled.

4. Release both buttons. The instrument will then return to the normal display mode.



Figure 19: Disable Alarm

6.9 Summary of Programme

Most settings do not need to be accessed during normal. Default values shown in *[brackets]*.

		Programming mode 1	Programming mode 2	Programming mode s
	Operating Mode	Select channel, press and hold 'SEL/+1' to enter	Power on whilst holding 'SEL/+1' to enter mode. Use same key to select channel	Power on whilst holding 'STOP/HA-0' for 10 seconds to enter mode. Use same key to select channel
Channel 1	Forward Speed	Speed sensor factor & autocal	Forward speed alarm	
	(Km/h)	Default: 2.000m/2 pulse	Default: 1 (on)	
Channel 2	Area x 2	Working width		Grand total area
	(Hectares)	Default: 4.000m		(Ha)
Channel 3	Tramlining	Tramline Sequence	Tramline option	
		Default: SY04	Default: 1 (on)	
Channel 4	Fan Speed	Low alarm speed	High alarm speed	Fan PPR
	(RPM)	Default: 3800 rpm	Default: 5000rpm	Default: 2.000
Channel 5	Shaft Speed	Low alarm speed		Shaft PPR
	(RPM)	Default: 0rpm		Default: 1.000
Channel 6	Hopper Alarm	Alarm on/off		
		Default: 1 (on)		

7. MAINTENANCE

7.1 GREASING

Grease regularly the following points:

- Every day, transmissions articulations.
- Each 100 ha graise the folding parts articulations.
- Each 400 ha graise the wheel axles and the transmission bushing.

7.2 WHEELS PRESSURE

Tyre 350/50-16 --- 3,75 kg/cm²

The information is prescribed by the tyre manufacturer. Full-load pressure.

Generally, in poor prepared soils, it is advisable to reduce a bit the lpressure in order to overcome the land irregularities and achieve more sowing regularity.

7.3 SCREW WORKS

After some working hours, all bolts must be verified and tightened if necessaty. In model 799 we supply a special key, a tube key, located inside the hopper, for the hold-down screw.

7.4 DISTRIBUTOR HEAD AND TUBES

Before working it is very important to verify that the seed delivery tubes and the distributor head are not blocked. For this, with the operating fan and with the full hopper , we will give some turns to the wheel to verify that the seed falls through the arms. Switch-off the machine and disconnect the head cover to verify that anything is inside.

8. DOSAGE TABLES



The quantities shown at the tables are for guidance only. The flow can change due to preservation powders, seed sizes, density, humidity...



For a precision sowing, we advise you to follow the dosage process described in the chapter 5.4 of this booklet.

SEED	WHEAT	RYE	BARLEY	OATS	BEANS	PEAS	LUPINES	VETCHES	CORN	GRASS	GRASS	RAPE	RED CLOVER	GRASS	TURN - BEETS					
	RELATIVE DENSITY (kg/l)	0.77	0.74	0.68	0.5	0.85	0.81	0.76	0.83	0.79	0.36	RELATIVE DENSITY (kg/l)	0.65	0.8	0.39	0.7				
SETPOINT VALUE	NORMAL SEED, KG/HA (LOCKING TAP POINTS TO THE METERING DEVICE)																			
10	31	31	30	22	21	20	26	30	7.4			1.98	0.99	2.1	1.07	2.36	1.12			
15	47	46	45	32	38	37	42	47	22	17		4.22	2.11	4.8	2.36	4.22	2.23			
20	64	62	60	43	57	55	57	64	43	24		6.32	3.1	7.9	3.97	2.6	1.3	6.94	3.47	
25	79	77	73	53	73	72	73	83	64	31		8.43	4.22	11	5.58	4.84	2.36	5.3	4.65	
30	97	93	88	66	91	91	89	100	86	38		10.5	5.33	14	7.07	6.7	3.35	11.7	5.83	
35	114	109	103	76	108	109	105	118	107	46		12.8	6.32	17	8.43	8.56	4.28	13.9	6.94	
40	130	124	118	87	125	126	120	135	128			14.8	7.32	20	9.8	10.4	5.21	16.2	8.13	
45	146	140	133	98	143	144	136	154	145			16.9	8.43	22	11.2	12.3	6.08	18.6	9.3	
50	161	156	148	109	160	161	153	171	162			19.1	9.55	25	12.3	13.9	6.94	20	9.99	
55	179	171	161	120	177	180	169	188	180			21.2	10.5	26	12.8	15.1	7.56	21.4	10.7	
60	195	186	177	131	195	198	184	206	197			N	M	N	M	N	M	N	M	
65	212	202	191	143	212	216	201	224	215			M = MICROMETERING								
70	229	218	206	154	229	233	217	242	232			PREVIOUS FLOW TEST:								
75	246	234	221	165	247	250	233	259	248			SEED DRILL	400/32	26.5	26.5	26.5	26.5	26.5	26.5	26.5
80	262	250	234	176	263	268	249	277	265			450/36	23.5	23.5	23.5	23.5	23.5	23.5	23.5	23.5
85	277	267	249	186	280	288	265	294	283			500/40	21	21	21	21	21	21	21	21
90	294	280	264	197	298	305	280	312	300			600/48	17.6	17.6	17.6	17.6	17.6	17.6	17.6	17.6
95	311	296	279	208	314	322	298	330	317			WHEEL TURNS NUMBER FOR SIMULATING THE 250M2								
100	327	312	294	219	331	340	312	347	335			SOWING THE FLOW IN KG/HA CAN BE GOT BY MULTIPLYING								
105	343	329	309	231	347	358	329	366	353			THE AMOUNT COLLECTED FOR 40.								
110	360	345	324	242	366	376	345	383	370											

NEUMASEM BOARD 400/450/500/600 WITH FLOTATION WHEELS 350/50-16

SEED	WHEAT	RYE	BARLEY	OATS	BEANS	PEAS	LUPINES	VETCHES	CORN	GRASS	RELATIVE DENSITY (kg/l)	SETPOINT VALUE	GRAPE	RED CLOVER	GRASS	TURN - BEETS			
RELATIVE DENSITY (kg/l)	0.77	0.74	0.68	0.5	0.85	0.81	0.76	0.83	0.79	0.36		SETPOINT VALUE	0.65	0.8	0.39	0.7			
SETPOINT VALUE	NORMAL SEED, KG/HA (LOCKING TAP POINTS TO THE METERING DEVICE)											FINE SEED, KG/HA (LOCKING TAP IN THE HEXAGONAL SHAFT GROOVE)							
10	25	25	24	18	17	16	21	24	6		2.5	1.6	0.8	1.7	0.86	1.9	0.9		
15	38	37	36	26	31	30	34	38	18	14	5	3.4	1.7	3.9	1.9	3.4	1.8		
20	52	50	48	35	46	44	46	52	35	19	7.5	5.1	2.5	6.4	3.2	2.1	1.05	2.8	
25	64	62	59	43	59	58	59	67	52	25	10	6.8	3.4	9	4.5	3.9	1.9	7.5	3.75
30	78	75	71	53	73	73	72	81	69	31	12.5	8.5	4.3	12	5.7	5.4	2.7	9.4	4.7
35	92	88	83	61	87	88	85	95	86	37	15	10.3	5.1	14	6.8	6.9	3.45	11.2	5.6
40	105	100	95	70	101	102	97	109	103		17.5	11.9	5.9	16	7.9	8.4	4.2	13.1	6.56
45	118	113	107	79	115	116	110	124	117		20	13.6	6.8	18	9	9.9	4.9	15	7.5
50	130	126	119	88	129	130	123	138	131		22.5	15.4	7.7	20	9.9	11.2	5.6	16.1	8.06
55	144	138	130	97	143	145	136	152	145		25	17.1	8.5	21	10.3	12.2	6.1	17.3	8.6
60	157	150	143	106	157	160	148	166	159			N	M	N	M	N	M	N	M
65	171	163	154	115	171	174	162	181	173			N = NORMAL SEED M = MICROMETERING							
70	185	176	166	124	185	188	175	195	187			PREVIOUS FLOW TEST:							
75	198	189	178	133	199	202	188	209	200			SEED DRILL TURNS							
80	211	202	189	142	212	216	201	223	214			600/40							
85	223	215	201	150	226	232	214	237	228			17,6							
90	237	226	213	159	240	246	226	252	242										
95	251	239	225	168	253	260	240	266	256										
100	264	252	237	177	267	274	252	280	270										
105	277	265	249	186	280	289	265	295	285										
110	290	278	261	195	295	303	278	309	298										

NEUMASEM BOARD 600 /40 WITH FLOTATION WHEELS 350/50-16

9. SPARE PARTS

The terms RIGHT (derecha), LEFT (izquierda), FRONT (delante) and iBACK (detrás) refers to the machine in starting direction.

In drawings we do not repeat the same spare parts, but with different hand. Codes are in spare parts chapters.

Please, when you order the spare parts, inform about the code and machine type. You will find it on the hopper identification nameplate.

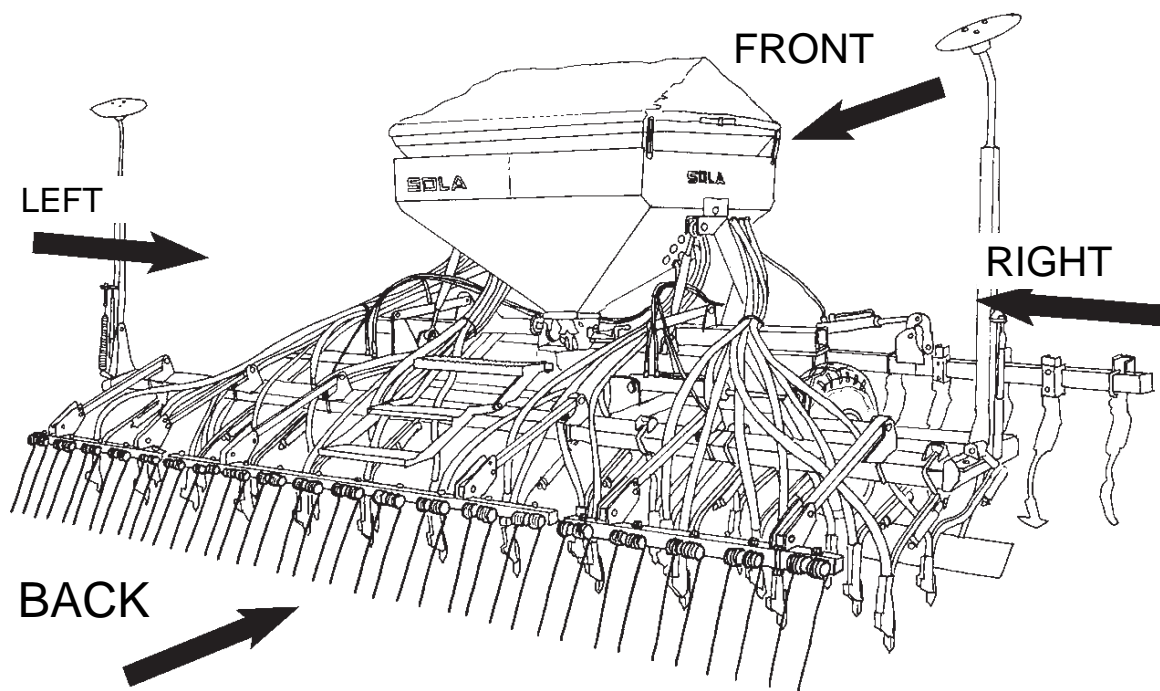

Be careful to change the elements of the sowing equipment, because the sharp elements can cause injuries.



As a general instruction, you must avoid working under the machine hanged up from the tractor. If you must do it, be extremely careful and secure it.

9.1 CHASSIS

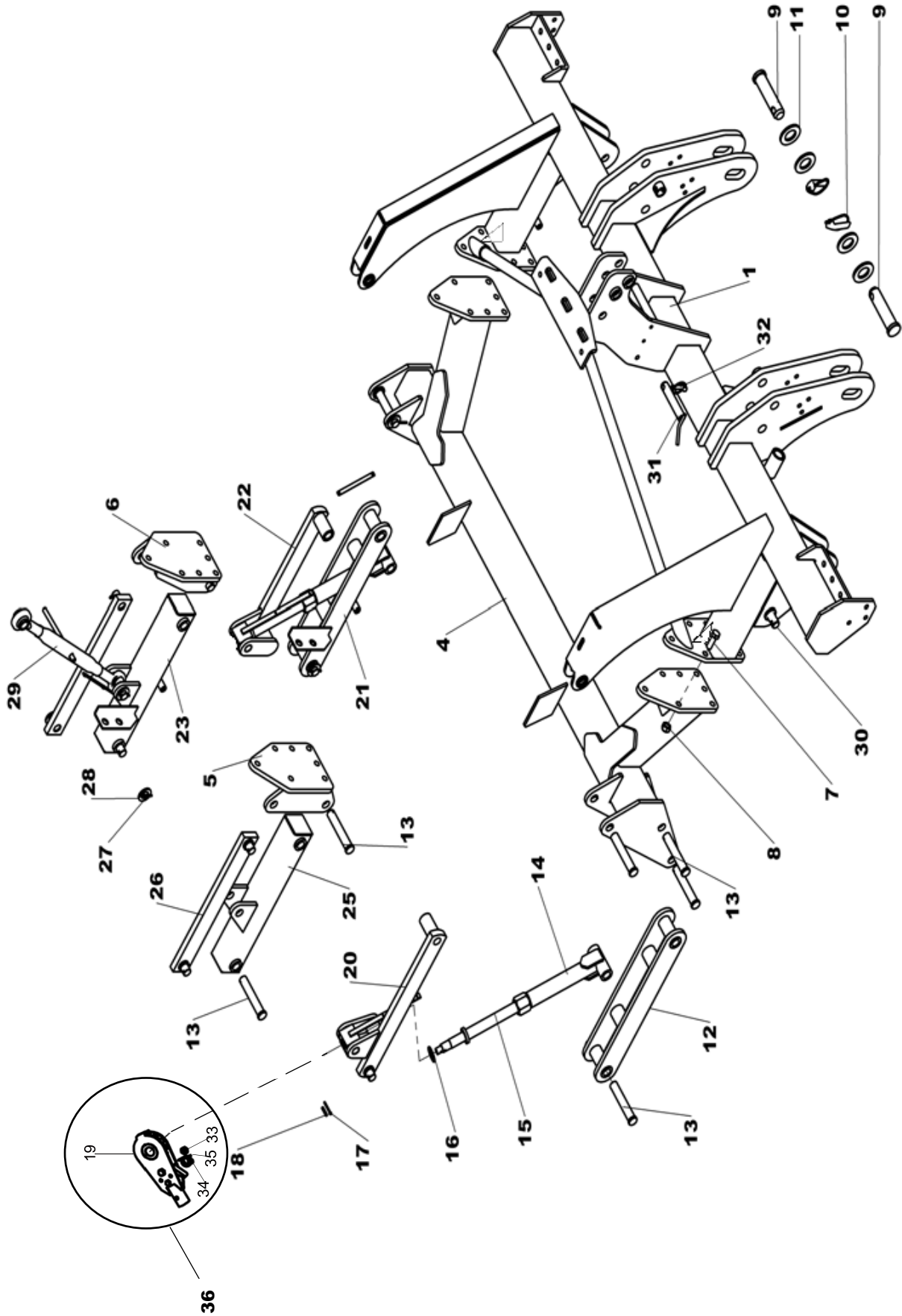

SPARE PARTS

Draw	Code
1	PS-011309
4	PS-011311
5	PS-011312/D
6	PS-011312/I
7	933 16x45 8.8 B
8	985 16
9	BU-011303
10	FE-610011
11	ARAN PLANA 39
12	PS-051340/D
13	BU-051301
14	PS-051342
15	PS-051343
16	A02-43
17	94 5x40 BI
18	6325 6X30
19	PS-051370
20	PS-051341/D
21	PS-051340/I
22	PS-051341/I
23	PS-051323/I
25	PS-051323/D
26	PS-051324
27	94 5x40 BI
28	125 24 BI
29	AF-051300
30	BU-051302
31	PS-010101
32	FE-610008
33	985 8
34	985 6
35	ML-051302
36	MO-051335

9.2 ARMS BAR 400,450,500

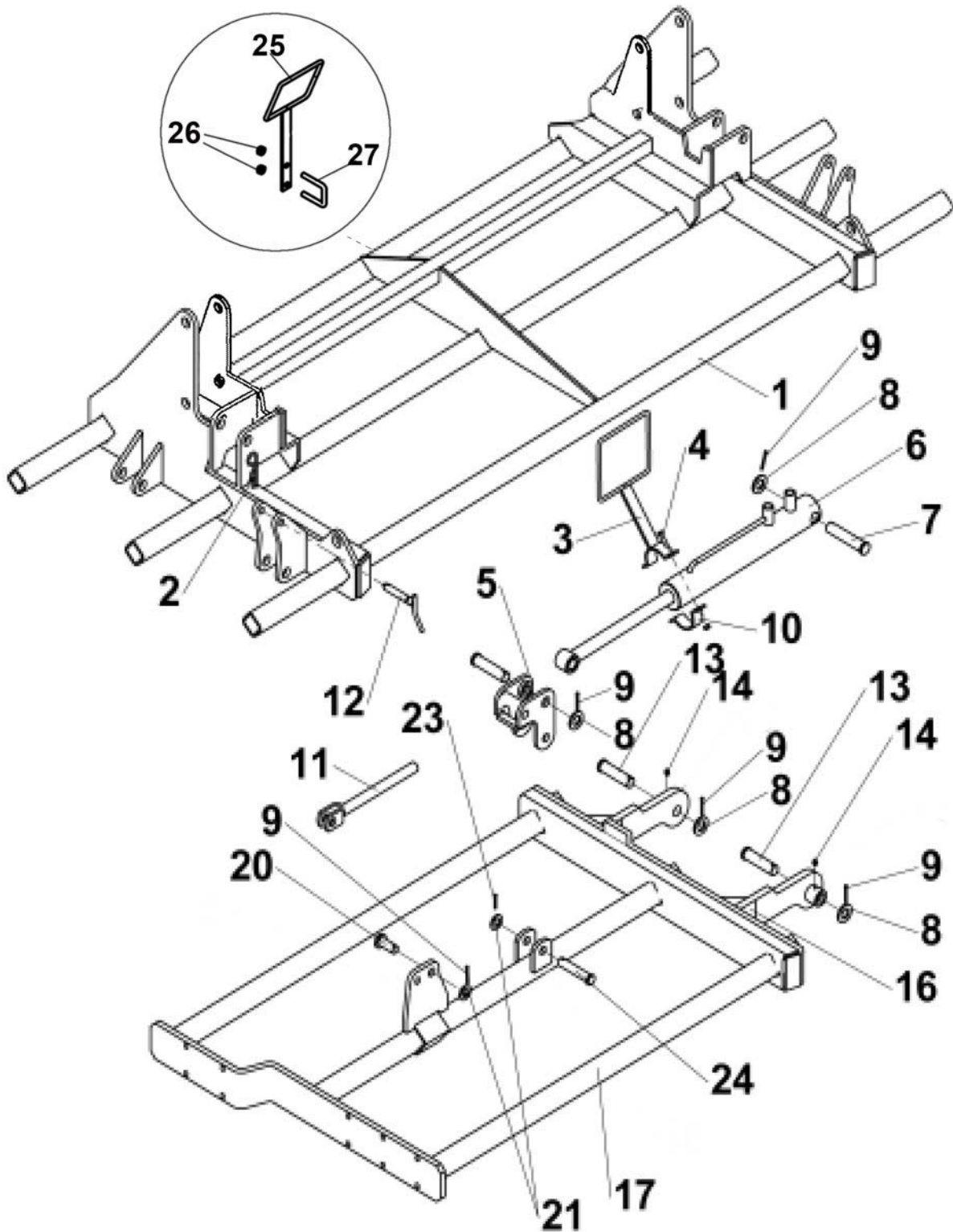

SPARE PARTS

Draw	Code
1	PS-051319
2	FE-610004
3	PS-051315
4	933 8x30 8.8 B
5	PS-051307
6	CO-051300
7	BU-061302
8	125 24 BI
9	94 5x40 BI
10	B10-44
11	TA-051328
	TA-051329
12	PS-051329
13	BU-051302
14	FE-603001
16	C01-180
17	PS-051320/D/I
	PS-051321/D/I
	PS-051322/D/I
20	B03-176
21	125 20 BI
23	94 5x32 BI
24	BU-051303
25	PS-051375
26	985 10
27	EE-101701

9.3 ARMS BAR 600

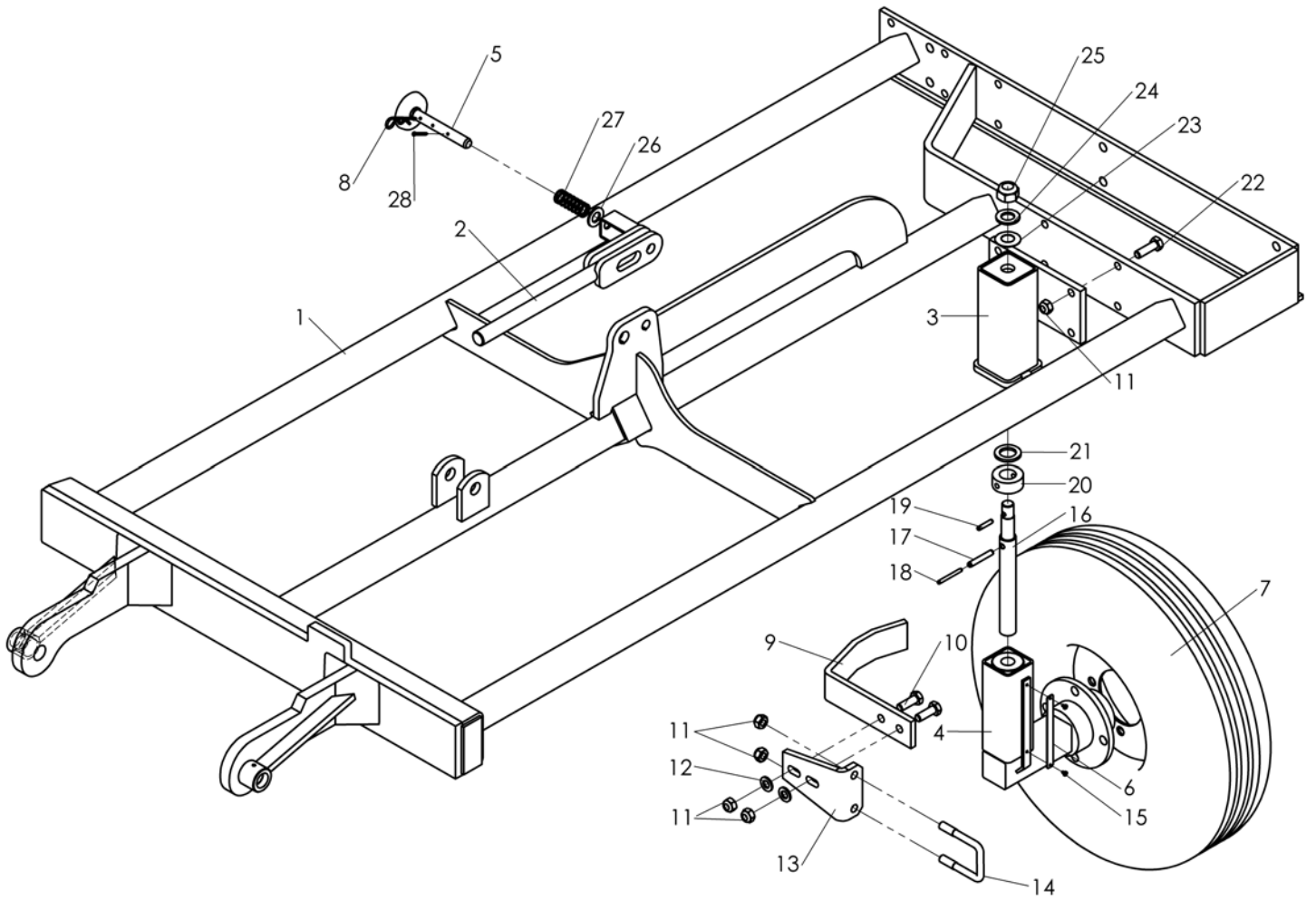

SPARE PARTS

Draw	Code
1	PS-051339/I PS-051339/D PS-053714/I PS-053714/D
2	PS-051328
3	PS-101364/D PS-101364/I
4	PS-101363
5	PS-051344
6	P09-09
7	CO-101305
8	FE-610002
9	EE-101345
10	933 12X35 8.8B
11	985 12
12	125 12 BI
13	PX-101338
14	EE-101346
15	FE-602001
16	ME-101331
17	1481 8X50 BI
18	1481 5X50 BI
19	1481 6X30 BI
20	T06-35
21	A02-27
22	933 12X40 8.8B
23	2093 40X20,4X1B
24	125 20 BI
25	985 20/150
26	125 16 BI
27	ML-050605
28	94 3,5x28 BI

9.4 ARMS BAR OF THE DISCS

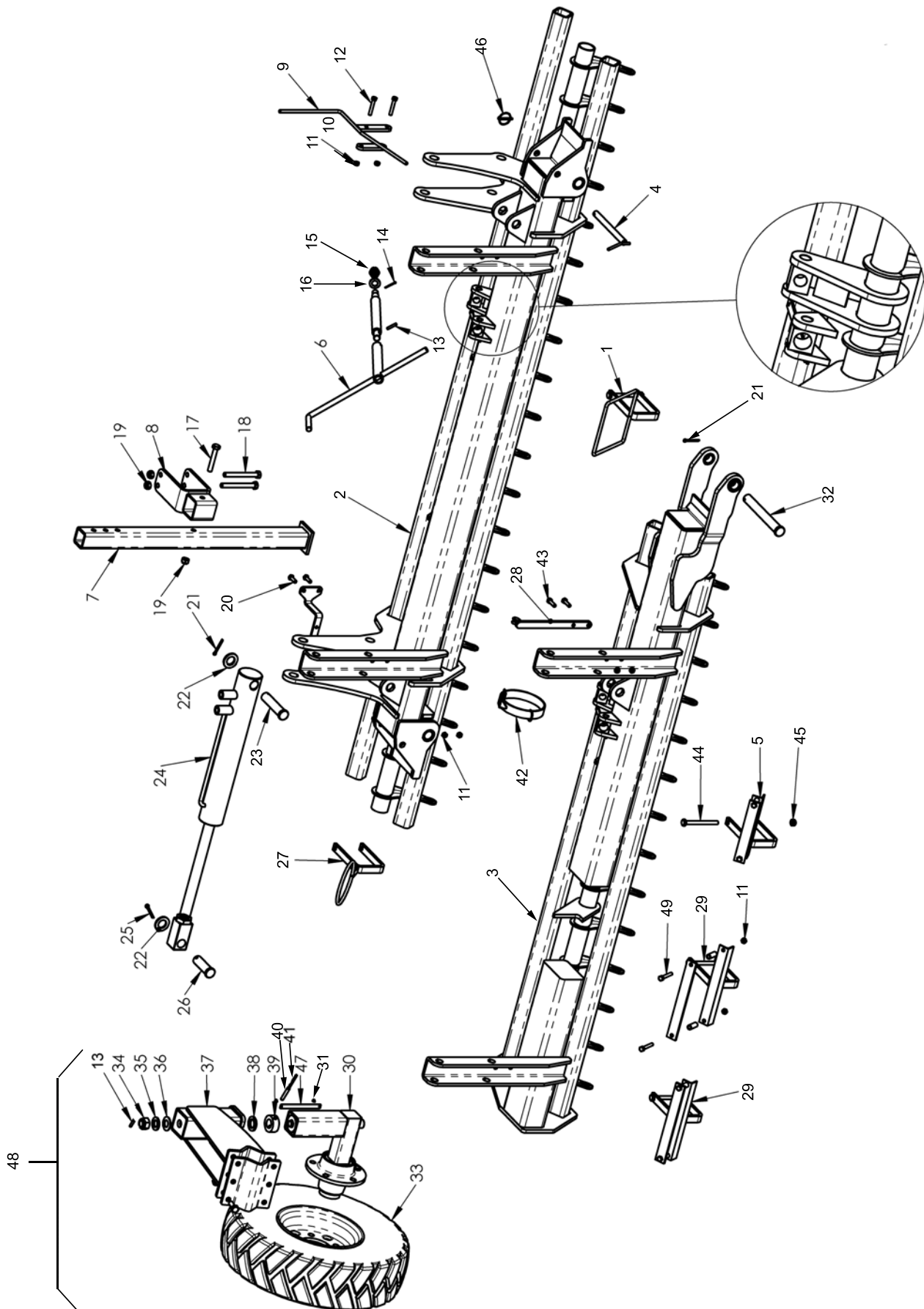

Drw	Code
1	PS-061377
2	PS-051356
3	PS-051357-D
	PS-051357-I
	PS-051358-D
	PS-051358-I
	PS-051359-D
	PS-051359-I
	PS-051360-D
	PS-051360-I
4	PS-051368
5	PS-051379/D
	PS-051379/I
6	PS-0814
7	PS-061373
8	PS-061372
9	PS-051385
10	PX-051372
11	985 8
12	933 8X50 8.8 B
13	1481 6X30 BI
14	94 3X28 BI
15	935 16 BI
16	125 16 BI
17	931 12X75 8.8B
18	931 12X110 8.8B
19	985 12
20	933 8X25 8.8B
21	94 5X40 BI
22	125 25 BI
23	BU-061306
24	CO-051305
25	94 6,3X40 BI
26	BU-042000
27	PS-061376
28	PS-051384
29	PS-051381
30	PS-101363

9.4 ARMS BAR OF THE DISCS

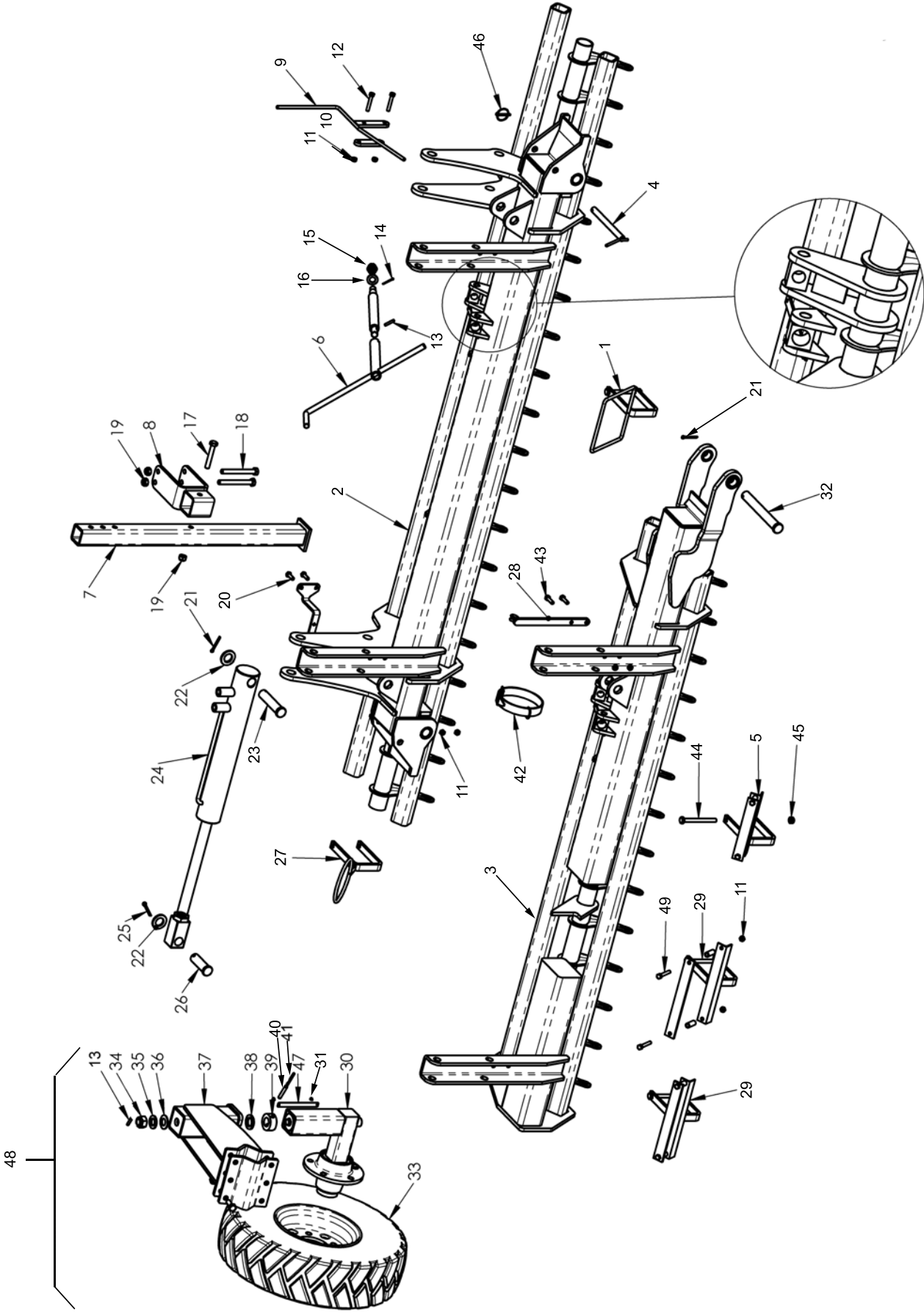

Drw	Code
31	FE-602001
32	BU-051307
33	CO-101305
34	985 20-150
35	125 20 BI
36	2093 40X20,4X1
37	PS-101367
38	A02-27
39	T06-35
40	1481 8X50 BI
41	1481 5X50 BI
42	CO-051306
43	933 8X30 8.8B
44	931 10X110 8.8B
45	985 10
46	FE-610005
47	P09-09
48	EO-101367
49	931 8X55 8.8B

9.5 ARMS BAR 4 ROWS

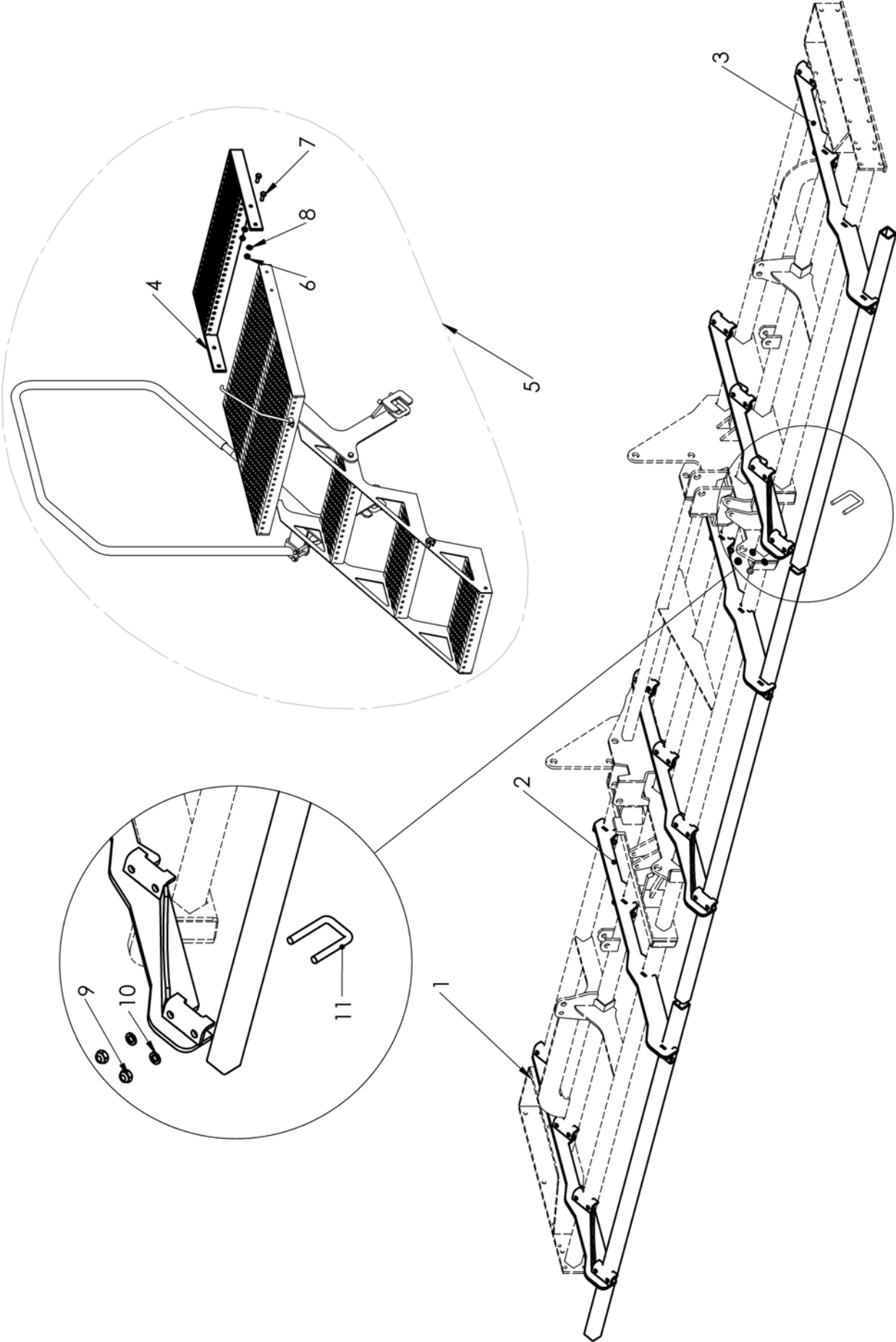

SPARE PARTS

Drw	Code
1	PS-051369/D
2	PS-051369/I
3	PS-051361/D
	PS-051361/I
4	PS-071325
5	MO-071311
6	985 10
7	933 10X30 8.8B
8	125 10 BI
9	985 14
10	127 14 BI
11	EE-050314

9.6 ARMS 799

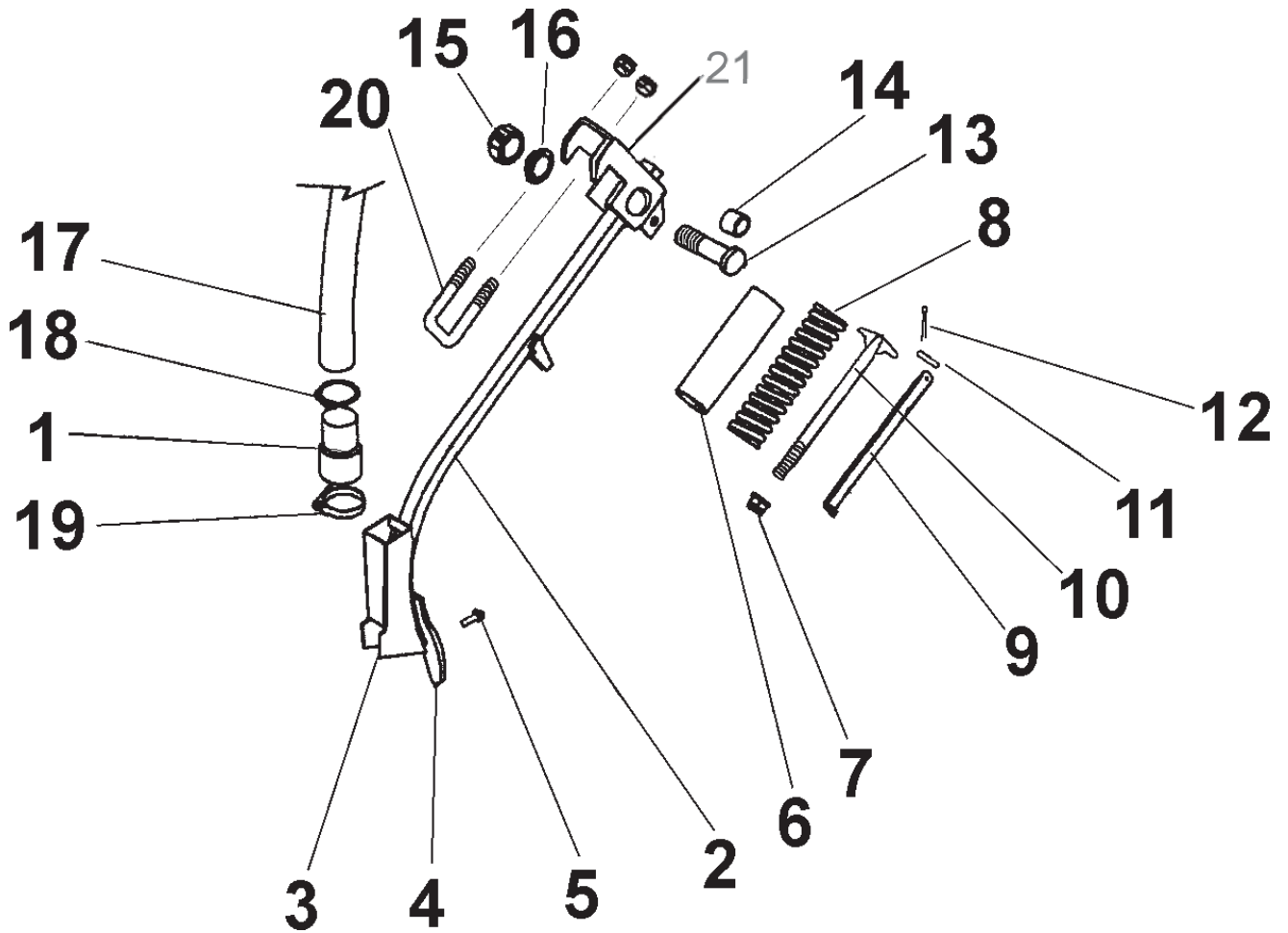

Draw	Code
1	PL-051300
	PS-2611
2	PS-2611/D
2	PS-2611/I
3	CO-051302
4	FO-050301
5	608/934 9x50
6	EE-050310
7	985 14
8	ML-050300I
9	EE-050301
10	FO-050303
11	BU-050302
12	94 3,5x20 BI
13	EE-050312
14	PL-050302
15	985 20/150 BI
16	125 20 BI
17	MP-907018
18	ML-051301
19	FE-606003
20	EE-050314
21	CO-050302

9.7 ARMS 699

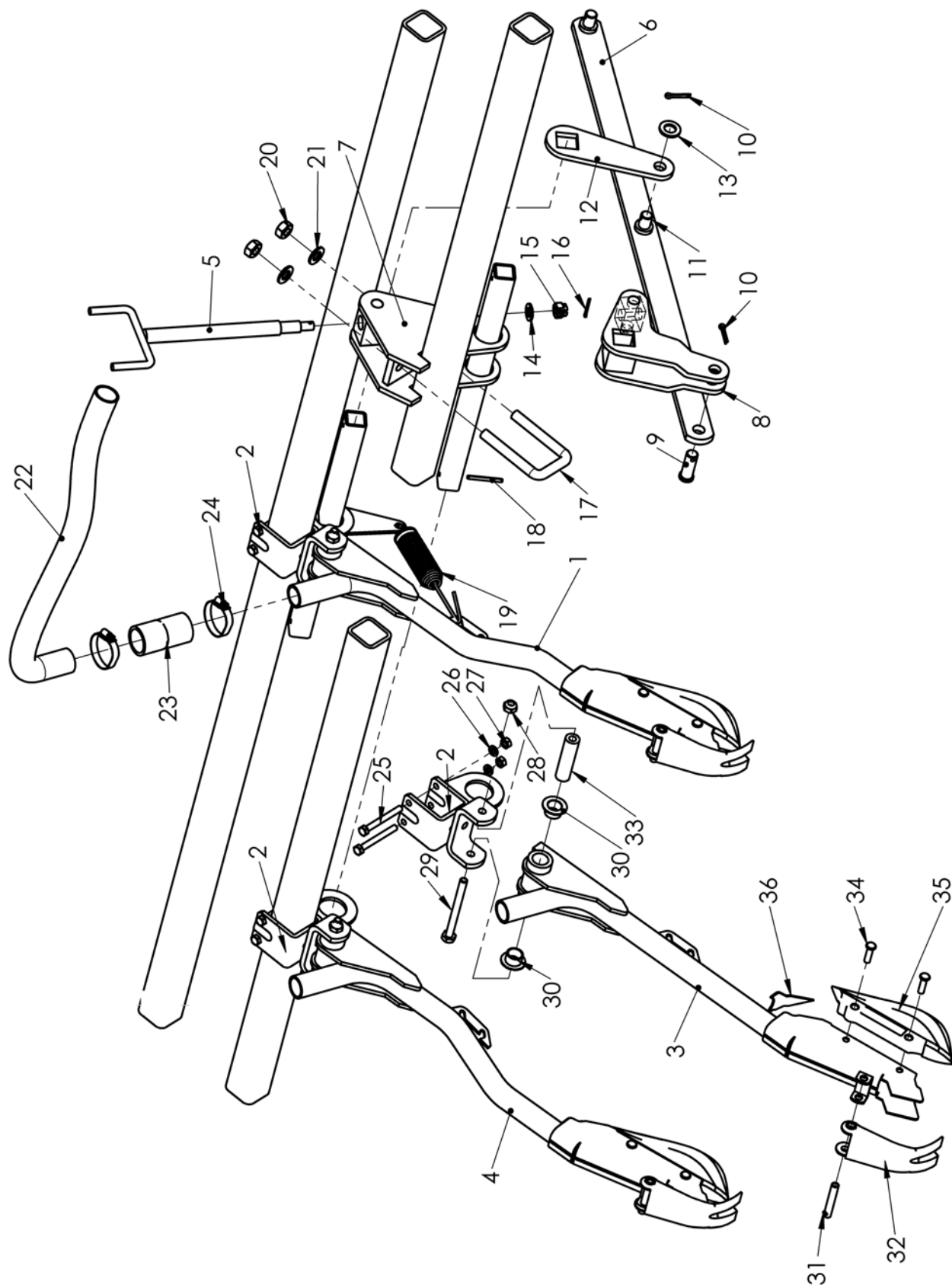

Drw	Code
1	MO-051339-D
	MO-051337-D
	PS-051373-D
2	PS-051367
3	PS-051372
	MO-051336
	MO-051338
4	MO-051339-I
	MO-051337-I
	PS-051373-I
5	PS-051313
6	PS-051345
7	PS-051310
8	PS-051311
9	B03-201
10	94 5X25 BI
11	B03-62
12	TA-051313
13	125 16 BI
14	125 12 BI
15	935 12 BI
16	94 3,5X28 BI
17	EE-050314
18	1481 5X50 BI
19	ML-051300
20	934 14 BI
21	125 14 BI
22	MP-907018
23	PL-051301
24	FE-606001
25	931 8X75 8.8B
26	127 8 BI
27	934 8 BI
28	985 10
29	931 10X110 8.8
30	PL-050207
31	BU-050202
32	EE-050206
33	ME-050202
34	FE-602000
35	FU-050200
36	PX-051343

9.8 ARMS OF THE DISCS

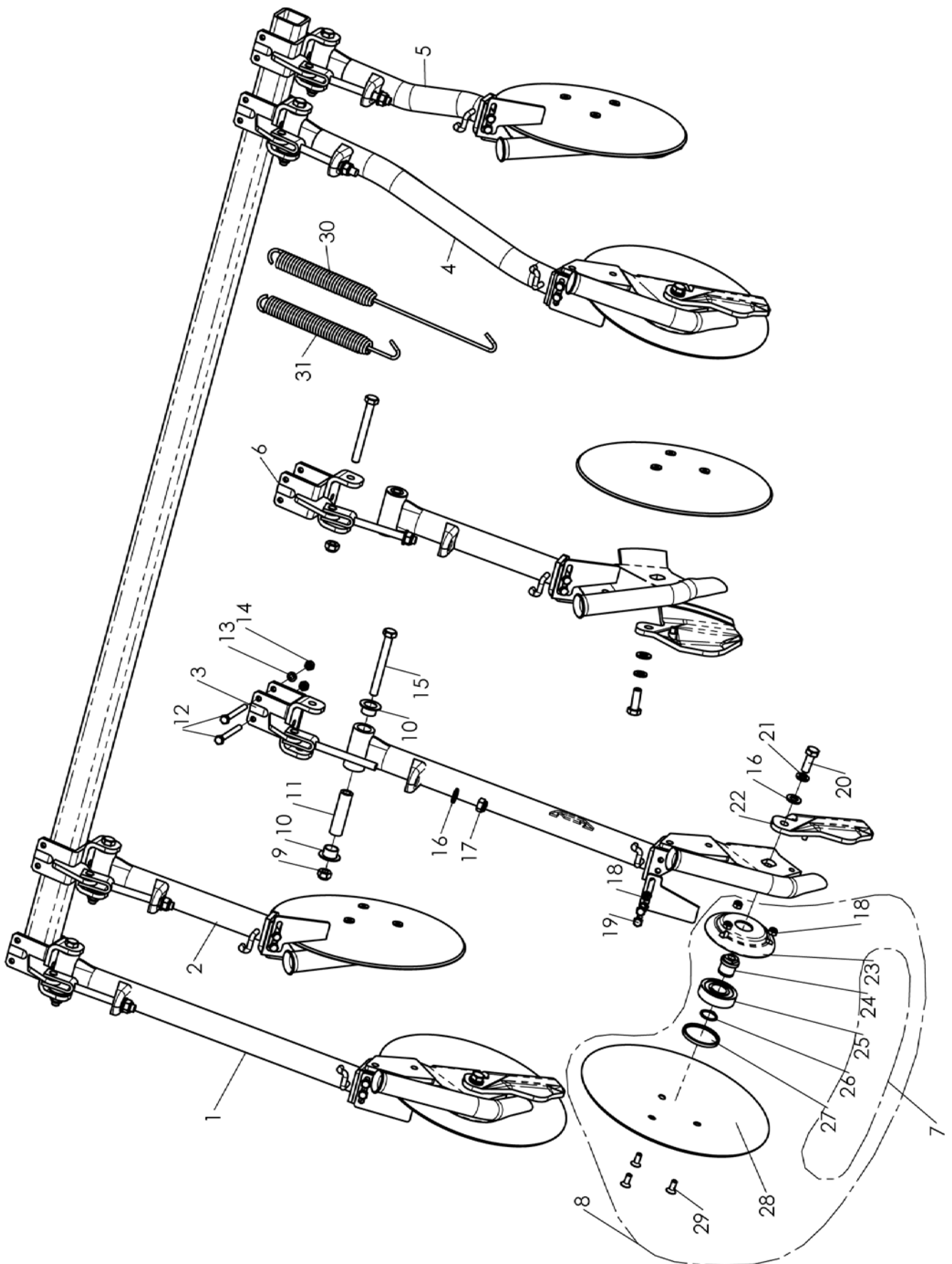

Draw	Code
1	PS-051602
1	MO-051601
2	PS-051603
2	MO-051602
3	PS-051376
4	PS-051605
4	MO-051604
5	PS-051610
5	MO-051607
6	PS-051377
7	MO-051600
8	MO-051620
9	985 12
10	PL-050207
11	ME-051322
12	931 8X75 8.8 B
13	127 8 BI
14	934 8 BI
15	931 12X110 8.8B
16	125 12 BI
17	985 2/25
18	985 8
19	933 8X20 8.8 B
20	933 12X35 8.8 B
21	127 12 BI
22	FU-051600/D
22	FU-051600/I
23	PL-051601
24	ME-051601
25	FE-600078
26	471 25
27	PL-051602
28	FO-051600
29	7991 8X20 10 B
30	ML-051602
31	ML-051601

9.9 HOPPER

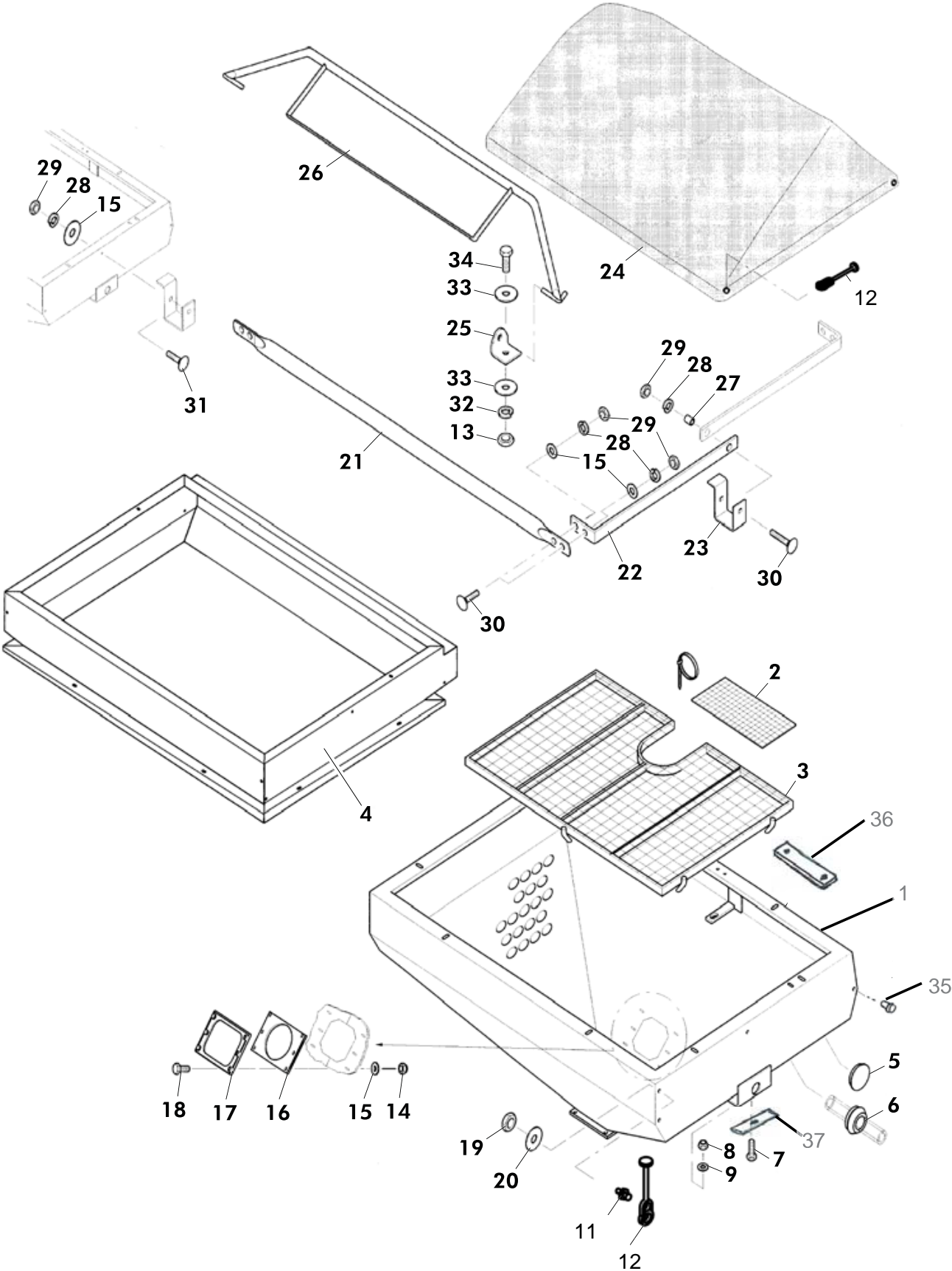

SPARE PARTS

Draw	Code
1	CO-021301
2	CO-021302
3	CO-021303
4	PS-021300
4	PS-021305
5	PL-021300
6	PL-021301
7	933 12X35 8.8 B
8	985 12
9	125 12 BI
11	ME-021702
12	PL-031300
13	934 8 BI
14	985 6
15	9021 6 BI
16	PL-021302
17	CO-021304
18	933 6X20 8.8 B
19	985 8
20	125 8 BI
21	CO-021305
22	CO-021306
23	CO-021307
24	RE-021300
25	CO-021308
26	CO-021309
27	CO-021310
28	127 6 BI
29	934 6 BI
30	603 6X25 BI
31	603 6X16 BI
32	127 8 BI
33	9021 8 BI
34	933 8X30 8.8 B
35	PL-021303
36	VA-021300
37	VA-021301

9.10 TRANSMISSION

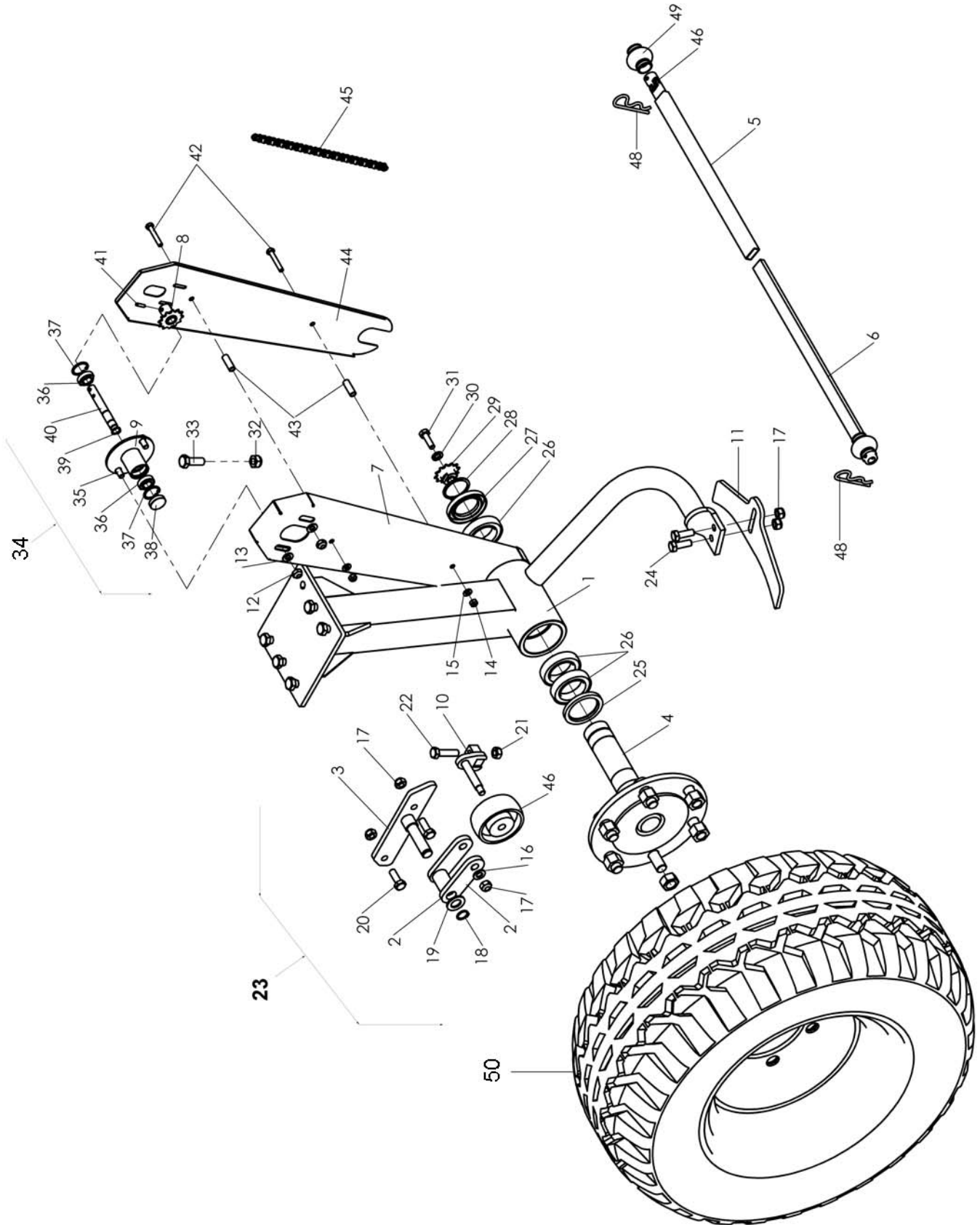

SPARE PARTS

Draw	Code
1	PS-041317/D PS-041317/I
2	PS-041351
3	PS-041350
4	ME-041306/D ME-041306/I
5	PS-041325
6	PS-041324
7	PS-041322
8	PS-041313 PS-041314
9	PS-041338
10	PS-041349
11	PX-041338
12	985 10
13	125 10 BI
14	985 8
15	125 8 BI
16	125 12 BI
17	985 12
18	471 20
19	125 20 BI
20	933 12X35 8.8B
21	934 12
22	933 12X50 8.8B
23	MO-041359
24	931 12X35 8.8B
25	FE-601017
26	FE-600037
27	FE-601012
28	471 50
29	ME-041338 ME-041339 ME-041340
30	127 12 BI
31	933 12X35 8.8B
32	985 14
33	933 14X40 8.8B
34	MO-041336
35	963 10X25
36	FE-600013
37	472 32
38	ME-041341
39	471 15
40	ME-041342
41	1481 5X22 BI
42	931 8X50 8.8B
43	CT-041322
44	PX-041304
45	FE-605079
46	CN-850070
47	PL-041714
48	FE-610004
49	FE-608023
50	CO-041300

9.11 DISTRIBUTION

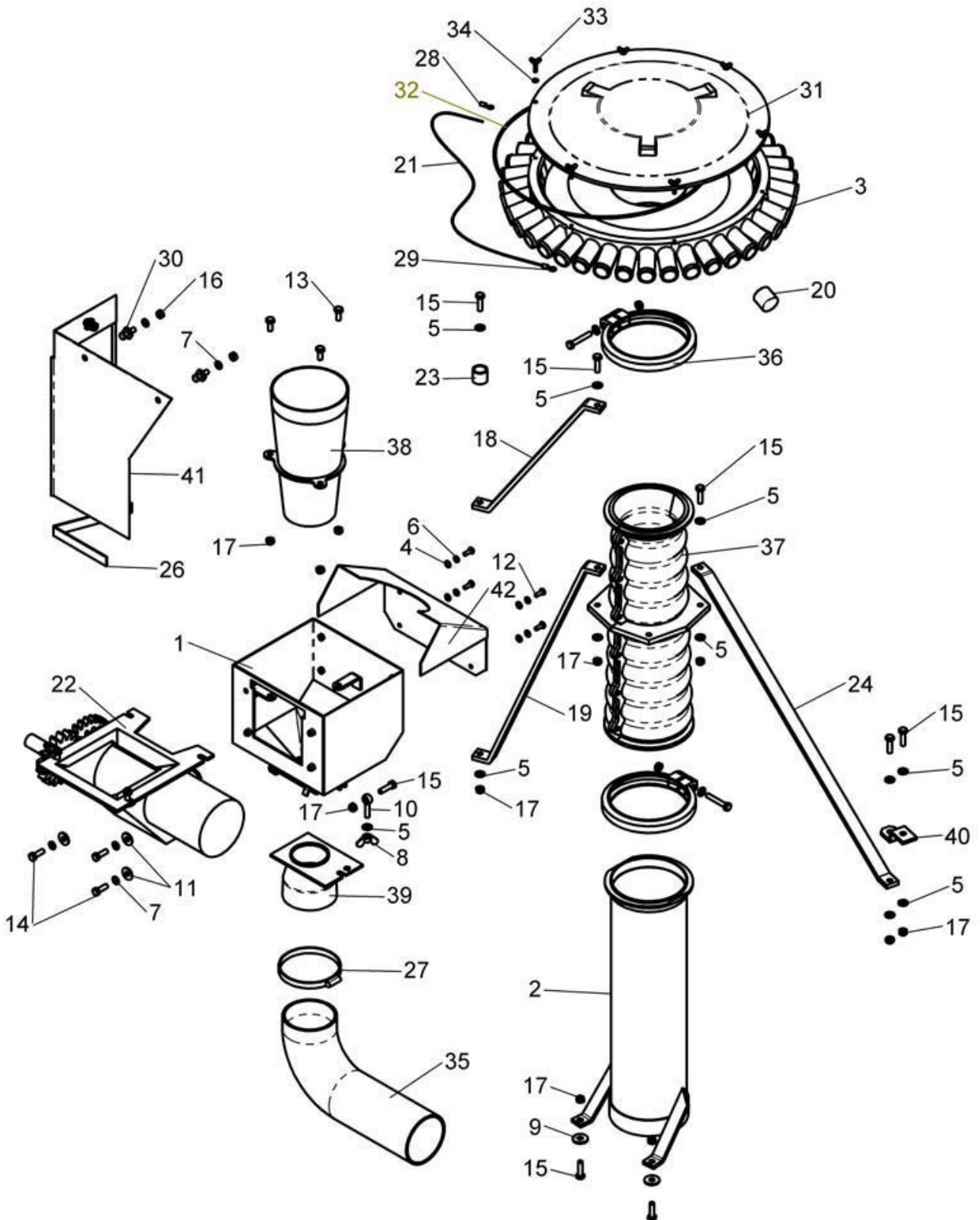

SPARE PARTS

Draw	Code
1	PS-041329
2	PS-041330
	PS-041331
3	MO-041345
	MO-041337
	MO-041323
4	125 6 BI
5	125 8 BI
6	127 6 BI
7	127 8 BI
8	315 8 BI
9	440 9 BI
10	444 8X40 8.8B
11	9021 8 BI
12	933 6X16 8.8 B
13	933 8X20 8.8 B
14	933 8X25 8.8 B
15	933 8X30 8.8 B
16	934 8
17	985 8
18	EE-041311
19	EE-041312
20	CN-817040
21	CN-816008
22	CO-041305
23	CT-041317
24	EE-041317
	EE-041318
26	EE-041327
27	FE-606008
28	FE-650018
29	FE-650019
30	ME-021702
31	ME-041355
	ME-041353
	ME-041329
32	FE-601049
	FE-601048
	FE-601034
33	316 5X20 BI
34	125 5 BI
35	MP-907006
36	PL-041302
37	PL-041303
38	PL-041304
39	PL-041305
40	PX-041306
41	VA-041305
42	PX-041324

9.12 DISTRIBUTION

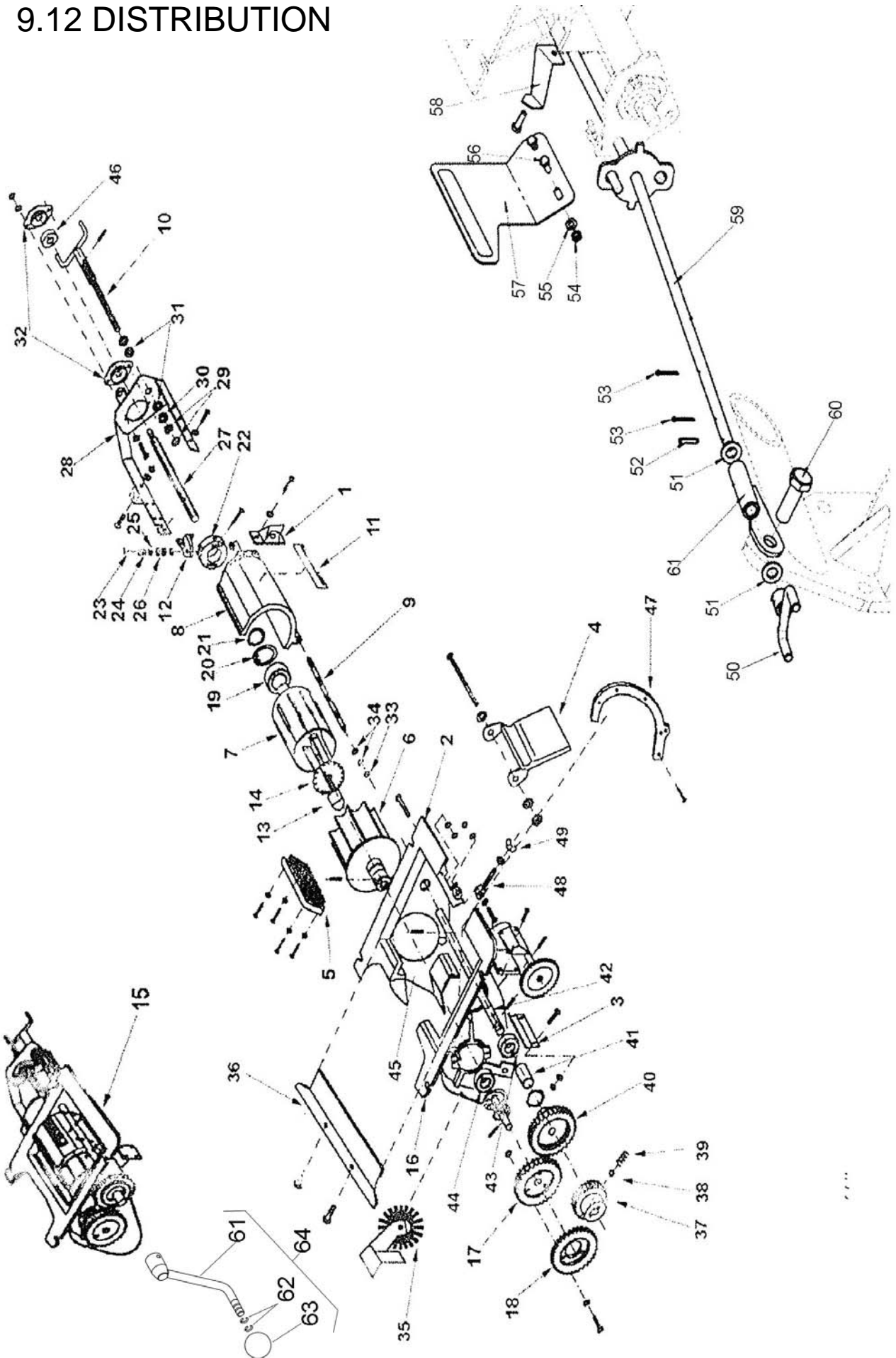

Draw	Code
1	AG-041300
2	AG-041301
3	AG-041302
4	AG-041303
5	AG-041304
6	AG-041305
7	AG-041306
8	AG-041307
9	AG-041308
10	AG-041309
11	AG-041310
12	AG-041315
13	AG-041316
14	AG-041317
15	CO-041305
16	AG-041318
17	AG-041319
18	AG-041320
19	FE-600064
20	472 75
21	471 45
22	AG-041321
23	920 4X20 BI
24	AG-041322
25	125 6 BI
26	137B 6
27	AG-041323
28	AG-041324
29	AG-041336
30	125 18 BI
31	137B 18
32	AG-041325
33	934 5 BI
34	125 5 BI
35	AG-041326
36	AG-041327
37	AG-041328
38	AG-041329
39	AG-041330
40	AG-041331

9.12 DISTRIBUTION

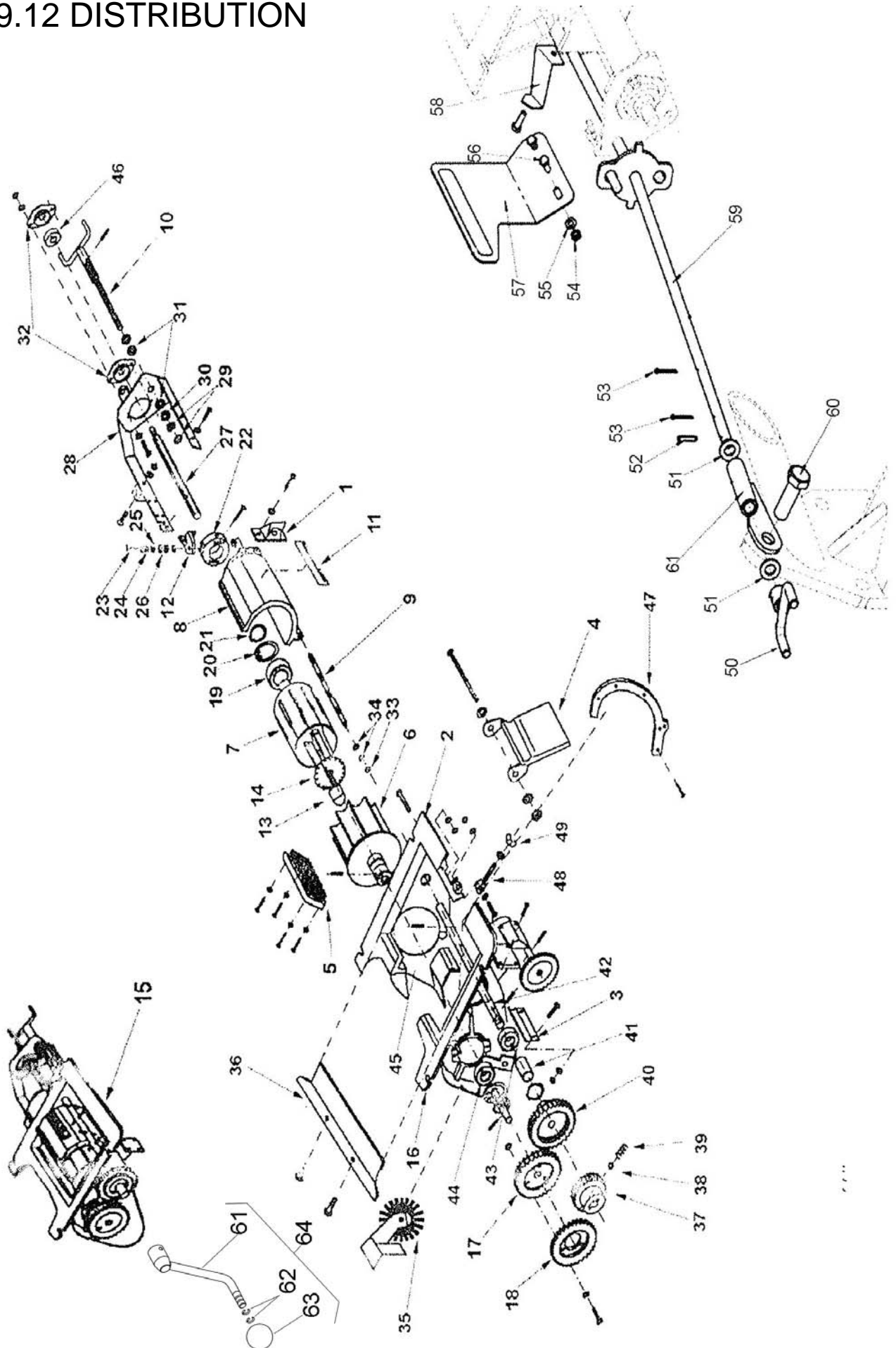

Draw	Code
41	AG-041332
42	AG-041333
43	CO-042404/11
44	FE-600047
45	1481 5X50 BI
46	AG-041334
47	AG-041335
48	444 8X35 BI
49	315 8 BI
50	PS-041373
51	125 12 BI
52	1481 5X22 BI
53	94 3,5X20 BI
54	985 6
55	125 6 BI
56	933 6X16 8.8 B
57	PX-041377
58	PX-041378
59	PS-041371
60	933 16X50 8.8 B
61	PS-041381
62	ML-041307
63	FE-611011
64	MO-041365

SPARE PARTS

Draw	Code
1	MO-041347
	MO-041356
2	ME-041346
3	PS-041328
4	PS-041334
	PS-041337
5	CO-041310
	CO-041502
6	7343 8X32
7	472 62
8	FE-600078
9	985 12
10	ME-041351
11	127 10 BI
12	912 10X50 8,8 B
13	127 8 BI
14	933 8X30 8.8B
15	125 8 BI
16	PL-041306
17	933 10X20 8.8 B
18	HI-700151
19	HI-700152
20	HI-700153
21	HI-701000
22	HI-701014
23	HI-701015
24	HI-703001
25	HI-703011
26	HI-704004
27	HI-704012
28	HI-704021
29	HI-705002
30	HI-705004
31	HI-706018
32	HI-708022
33	HI-708027
34	HI-708028
35	125 12 BI
36	125 20 BI
37	125 30 BI
38	6885-A 6X6X35
39	912 8X30 8,8
40	934 10
41	94 5X40 BI
42	985 20
43	ME-041348
	ME-041360
44	ME-041350
45	ME-041349
46	ME-041347
47	ME-011305

9.14 MECHANICAL FAN 1

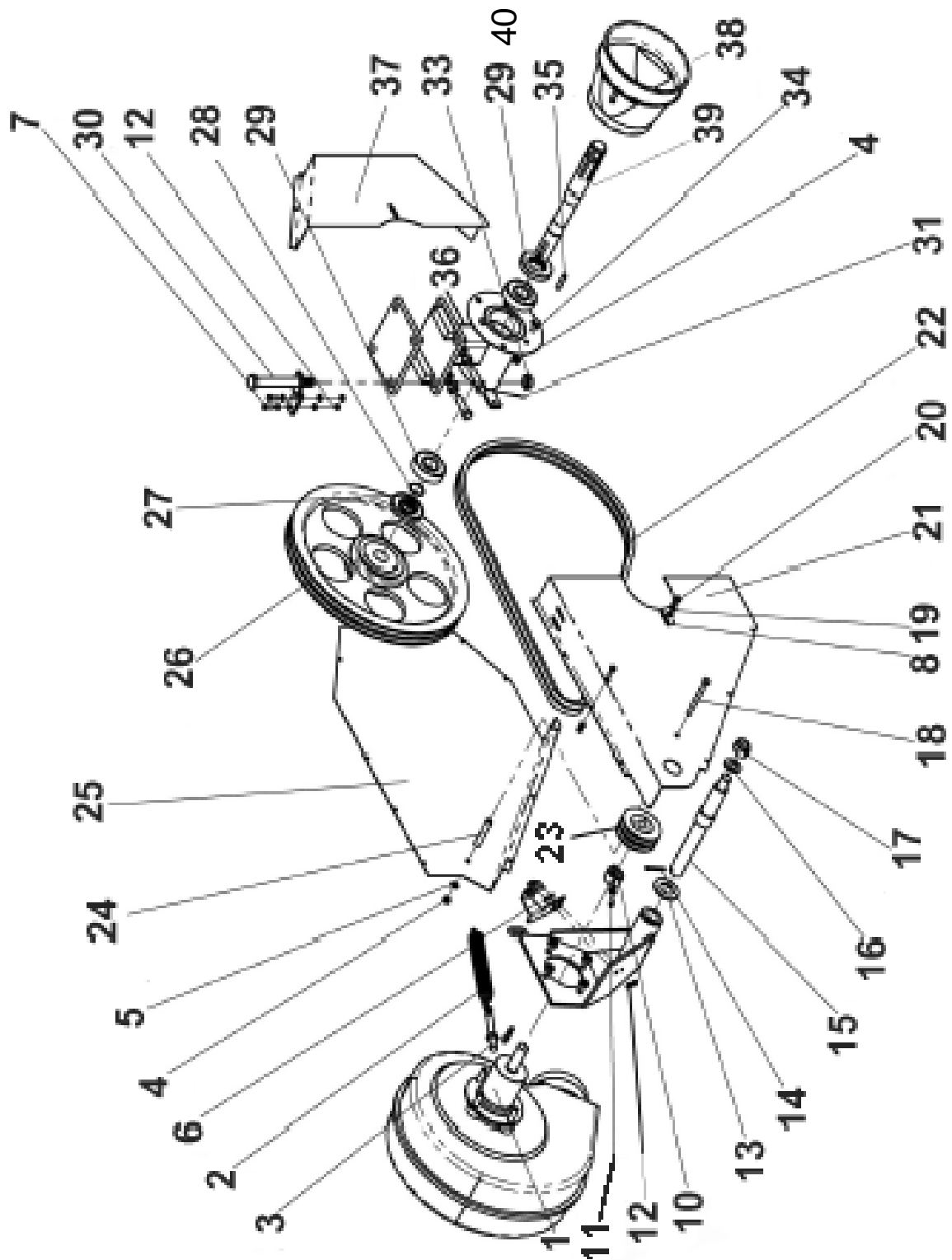

SPARE PARTS

Draw	Code
1	VA-041300
2	ML-051601
3	6885-A 6X6X35
4	985 8
5	125 8 BI
6	PX-041322
7	933 6x20 8.8 B
8	125 6 BI
10	ME-041334
11	933 8X20 B PUNTA
12	985 6
13	125 30 BI
14	94 5x40 BI
15	ME-011305
16	125 20 BI
17	985 20
18	931 8x90 8.8 BI
19	127 6 BI
20	933 6x16 8.8 B
21	PX-041317
22	FE-604041
23	MO-041326
24	CT-041313
25	PX-041319
26	MO-041325
27	FE-601042
28	471-30
29	FE-600051
30	931 14X150 8.8 BI
31	933 12X45 8.8 B
33	985 14
34	933 8x16 8.8 BI
35	6885-A 8X7X30
36	PS-041320
37	PX-041318
38	TA-041306
39	ME-041332
40	FE-60104.

9.15 MECHANICAL FAN 2

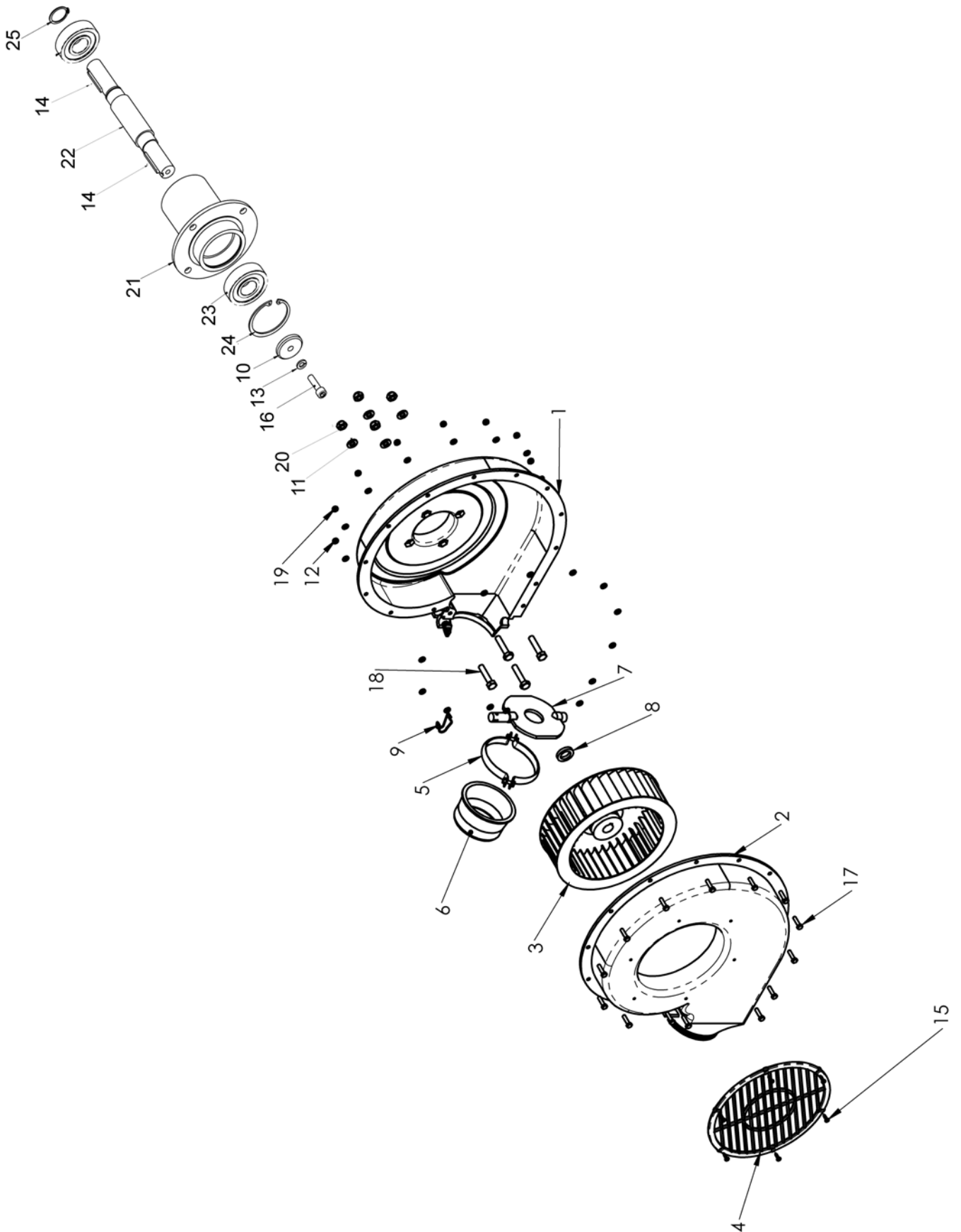

Draw	Code
1	CO-041310/01
2	CO-041310/02
3	CO-041310/03
4	CO-041310/04
5	CO-041310/05
6	CO-041310/06
7	CO-041310/07
8	CO-041310/08
9	CO-041310/09
10	ME-041351
11	125 10 BI
12	125 6 BI
13	127 8 BI
14	6885-A 6X6X35
15	7971 4,2X16 B
16	912 8X30 8.8
17	933 6X25 8.8 B
18	933 10X50 8.8 B
19	985 6
20	985 10
21	CO-041313/01
22	CO-041313/02
23	FE-600034
24	472 62
25	471 25

9.16 BIG MECHANICAL FAN

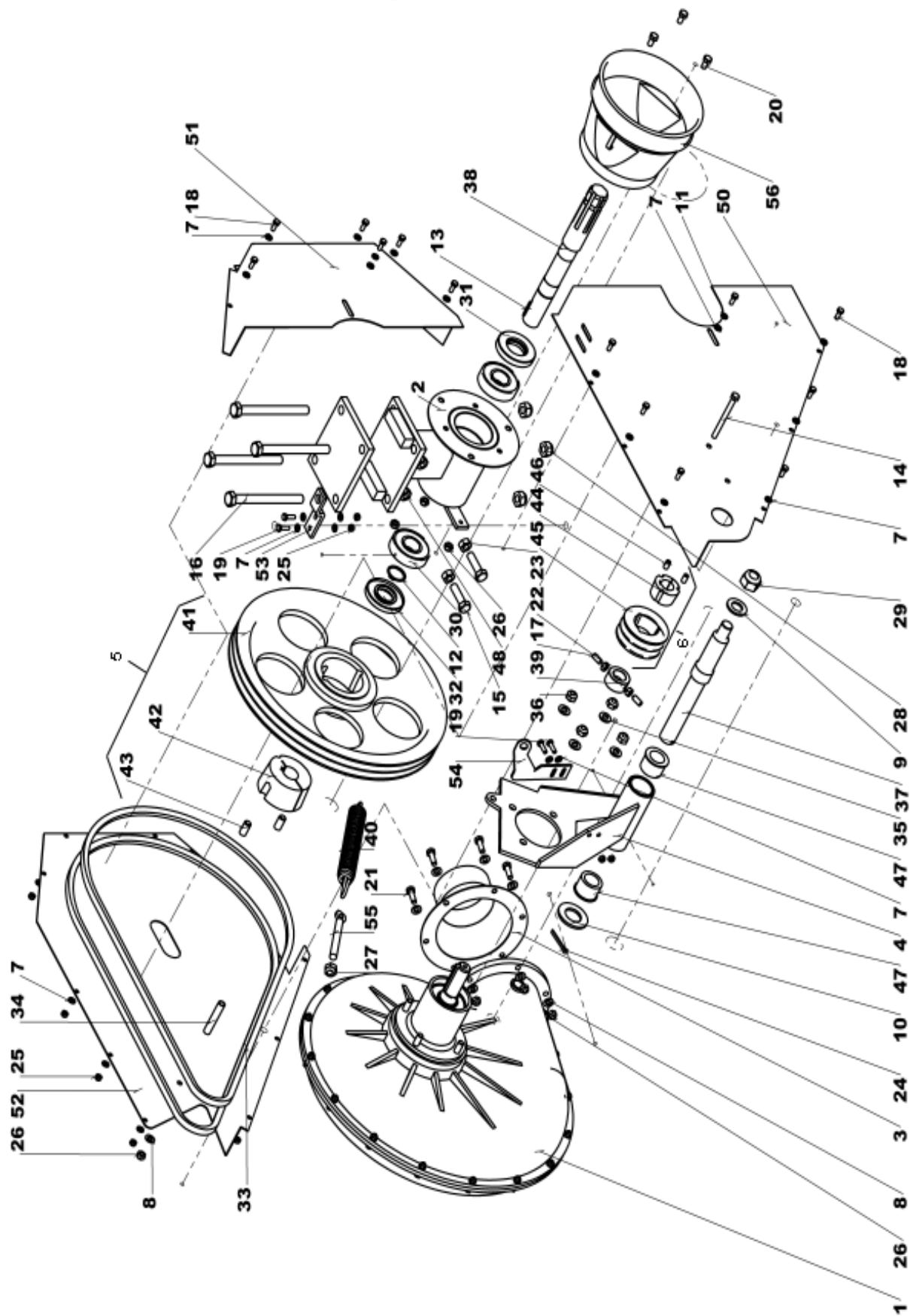

SPARE PARTS

Draw	Code
1	CO-041500 CO-041502 CO-041500-02
2	PS-041320
3	PS-041335
4	PS-041337
5	MO-041325
6	MO-041327
7	125 6 BI
8	125 8 BI
9	125 20 BI
10	125 30 BI
11	127 6 BI
12	471 30
13	6885-A 8X7X30
14	931 8X90 8.8B
15	931 12X45 8.8B
16	931 14X150 8.8B
17	933 8X20 B PUNTA
18	933 6X16 8.8B
19	933 6X20 8.8B
20	933 8X16 8.8B
21	933 8X25 8.8B
22	934 8 BI
23	934 12 BI
24	94 5X40 BI
25	985 6
26	985 8
27	985 12-150
28	985 14
29	985 20
30	FE-600051
31	FE-601041
32	FE-601042
33	FE-604049
34	CT-041313
35	125 10 BI
36	985 10
37	ME-011305
38	ME-041332
39	ME-041363
40	ML-051601
41	FE-604016
42	FE-604019

9.16 BIG MECHANICAL FAN

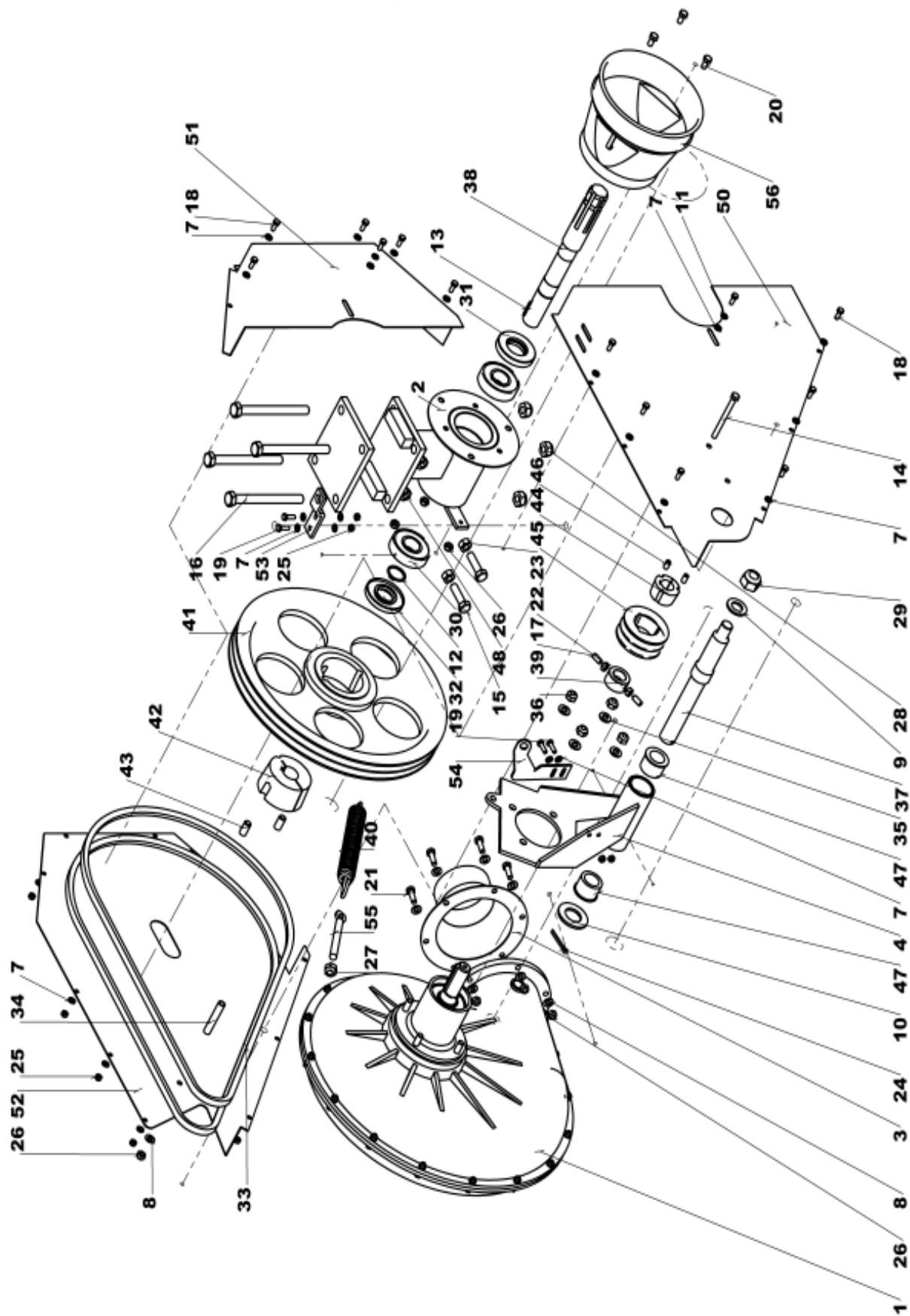

Draw	Code
43	913 12X25 BI
44	FE-604047
45	FE-604017
46	913 8X15 BI
47	PL-041306
48	934 12
50	PX-041317
51	PX-041318
52	PX-041319
53	PX-041320
54	PX-041322
55	EE-100210
56	TA-041306

9.17 MECHANICAL FAN 3D

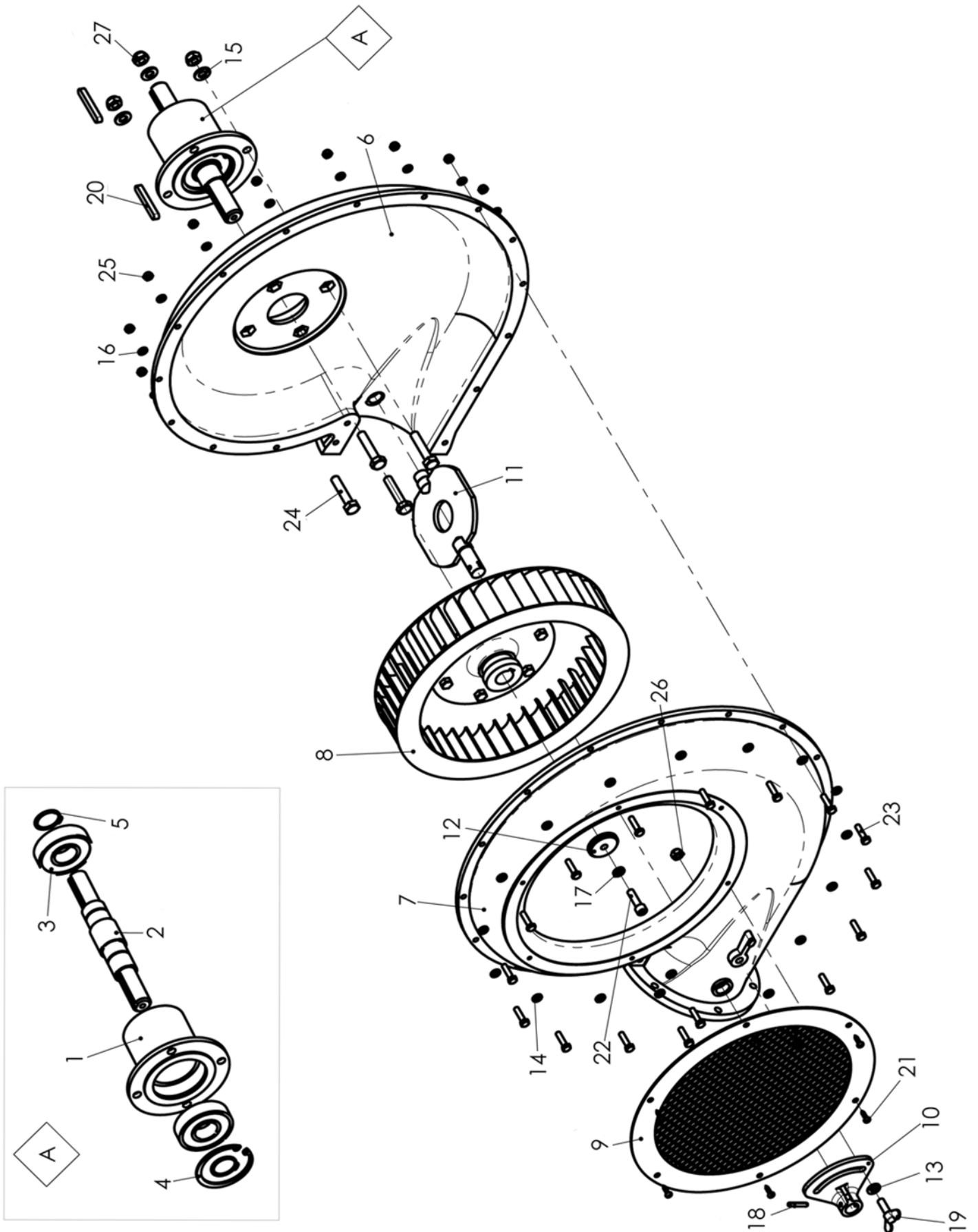

Draw	Code
1	CO-041500-00
2	CO-041500-01
3	FE-600051
4	472 72
5	471 30
6	CO-041502-00
7	CO-041502-01
8	CO-041502-02
9	CO-041502-03
10	CO-041502-04
11	CO-041310-07
12	ME-041351
13	125 8 BI
14	125 6 BI
15	125 10 BI
16	127 6 BI
17	127 8 BI
18	1481 5X28 BI
19	316 8x25 BI
20	6885-A 8X7X50
21	7971 4,2X16 BI
22	912 8X30 8.8
23	933 6X25 8.8B
24	933 10X50 8.8 B
25	985 6
26	985 8
27	985 10
A	CO-041500-02

9.18 REAR CULTIVATOR ARM

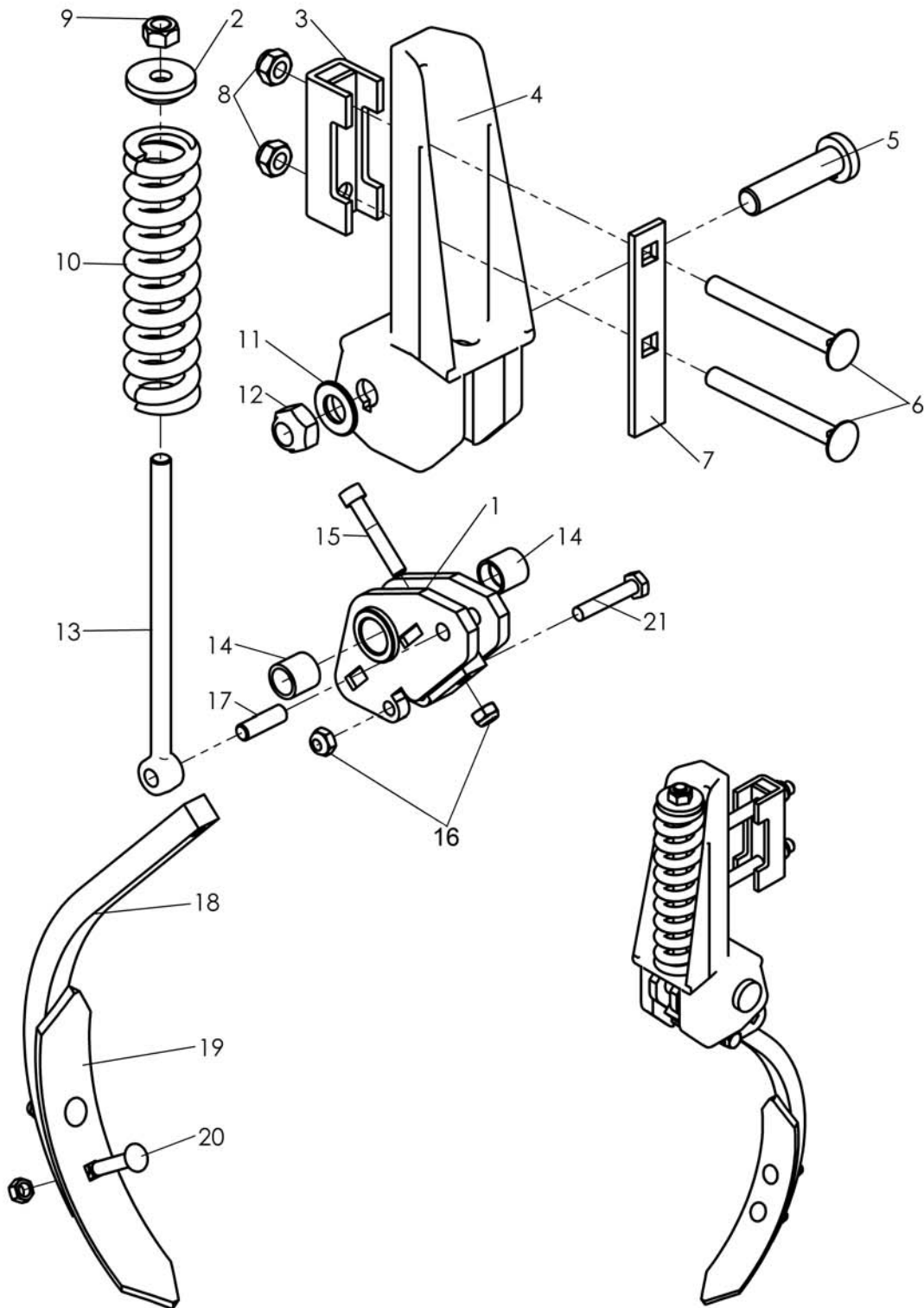

SPARE PARTS

Draw	Code
1	PS-062100
2	PS-1115
3	PS-061378
4	PS-062101
5	EE-050312
6	603 14x130 8.8 B
7	PX-061325
8	985 14
9	980 14 BI
10	ML-062100
11	125 20 BI
12	985 20-150
13	FO-062100
14	PL-050302
15	912 10X60 8,8 B
16	985 10
17	BU-062100
18	FO-061303
19	R08-04
20	608-934 9X40
21	931 10x55 BI
22	MO-061330
	MO-061349

9.19 REAR CULTIVATOR

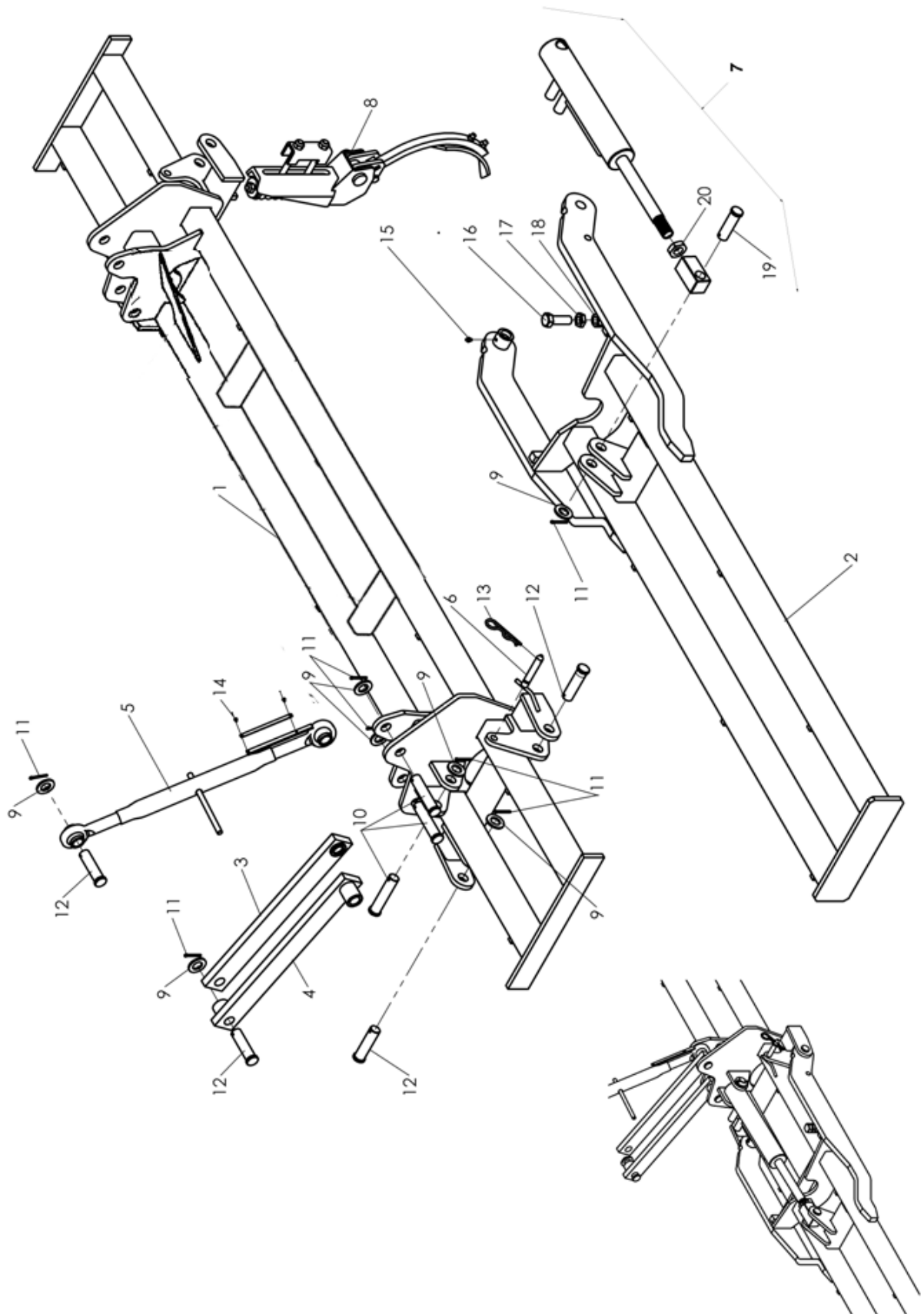

Draw	Code
1	PS-061346
2	PS-061347/D/I
	PS-061348/D/I
	PS-061349/D/I
	PS-061350/D/I
3	PS-061344
4	PS-061345
5	PS-061351
6	PS-051329
7	CO-061301
8	MO-061330
	MO-061349
9	125 24 BI
10	BU-061306
11	94 5X40 BI
12	BU-051302
13	FE-610004
14	FE-602001
15	FE-603001
16	933 20X60 8.8 B
17	936 20 BI
18	6330 20
19	BU-061305
20	936 27X1,5 BI

9.20 AFLOAT CULTIVATOR

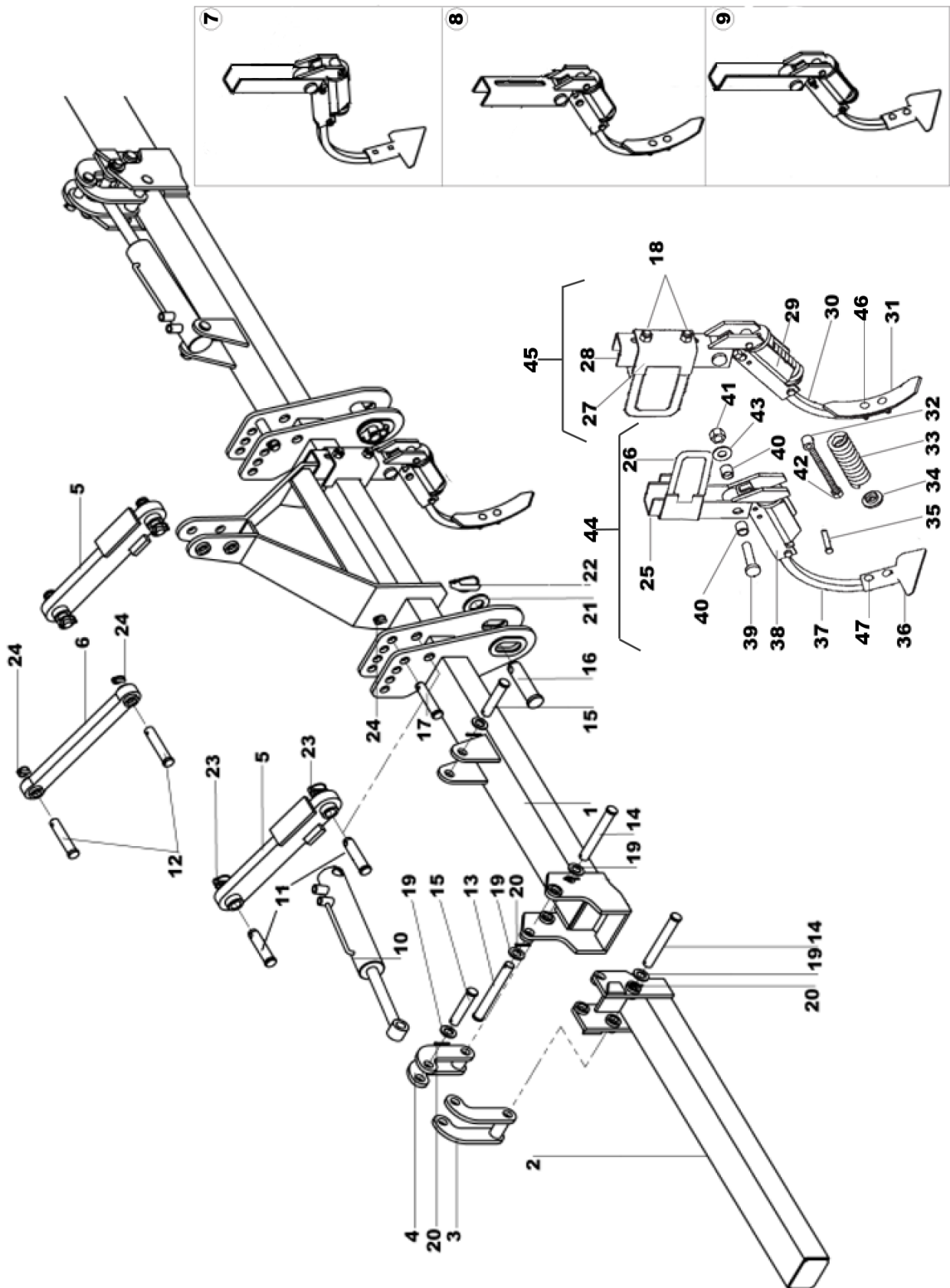

SPARE PARTS

Draw	Code
1	PS-061340
2	PS-061311
	PS-061312
	PS-061313
3	PS-061302
4	PS-061303
5	PS-061367
6	PS-061323
7	MO-0720/B
8	MO-0719/B
9	MO-061310
10	SC-57
11	BU-061308
12	B03-132
13	BU-061300
14	BU-061301
15	B03-252
16	BU-011303
17	BU-061307
18	985 16
19	125 25 BI
20	94 5X36 BI
21	ARAN PLANA 39B
22	FE-610011
23	FE-610008
24	FE-610007
25	PS-1117
	PS-061320
26	EE-060230
27	PX-060202
28	PS-1113
29	PS-1120
30	FO-060302
31	FO-060300
32	FO-060202
33	ML-060300
34	PS-1115
35	BU-060300
36	FO-060301
37	FO-060303
38	PS-1121
39	EE-050312
40	PL-050302
41	985 20/150
42	980 14 BI
43	125 20 BI
44	MO-0730
45	MO-0721
46	608/934 9X40
47	608/934 9X35

9.21 FLAT LEVELER

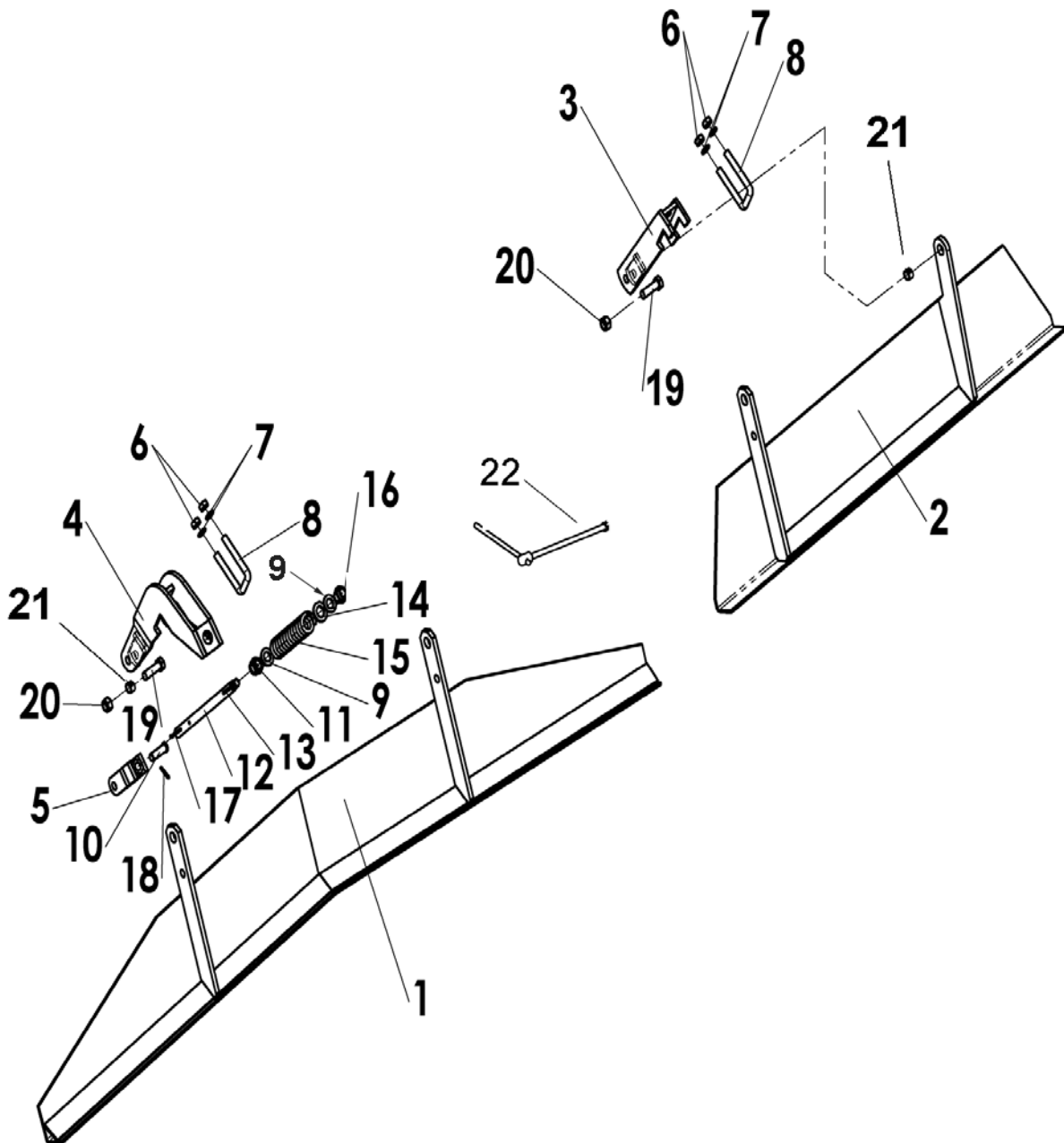

Draw	Code
1	PS-061354
2	PS-061355/D
	PS-061355/I
	PS-061356/D
	PS-061356/I
	PS-061357/D
	PS-061357/I
	PS-061358/D
	PS-061358/I
3	PS-061305/D
	PS-061305/I
4	PS-061352
5	PS-061318
6	934 14 BI
7	127 14 BI
8	EE-050314
9	125 20 BI
10	BU-050303
11	935 20 BI
12	ME-061305
13	1481 5X30 BI
14	ME-061303
15	ML-050300
16	985 20
17	94 4X32 BI
18	94 5X25 BI
19	931 16X55 8.8B
20	985 16
21	ME-061301
22	PS-061374

9.22 LEVELER TINES

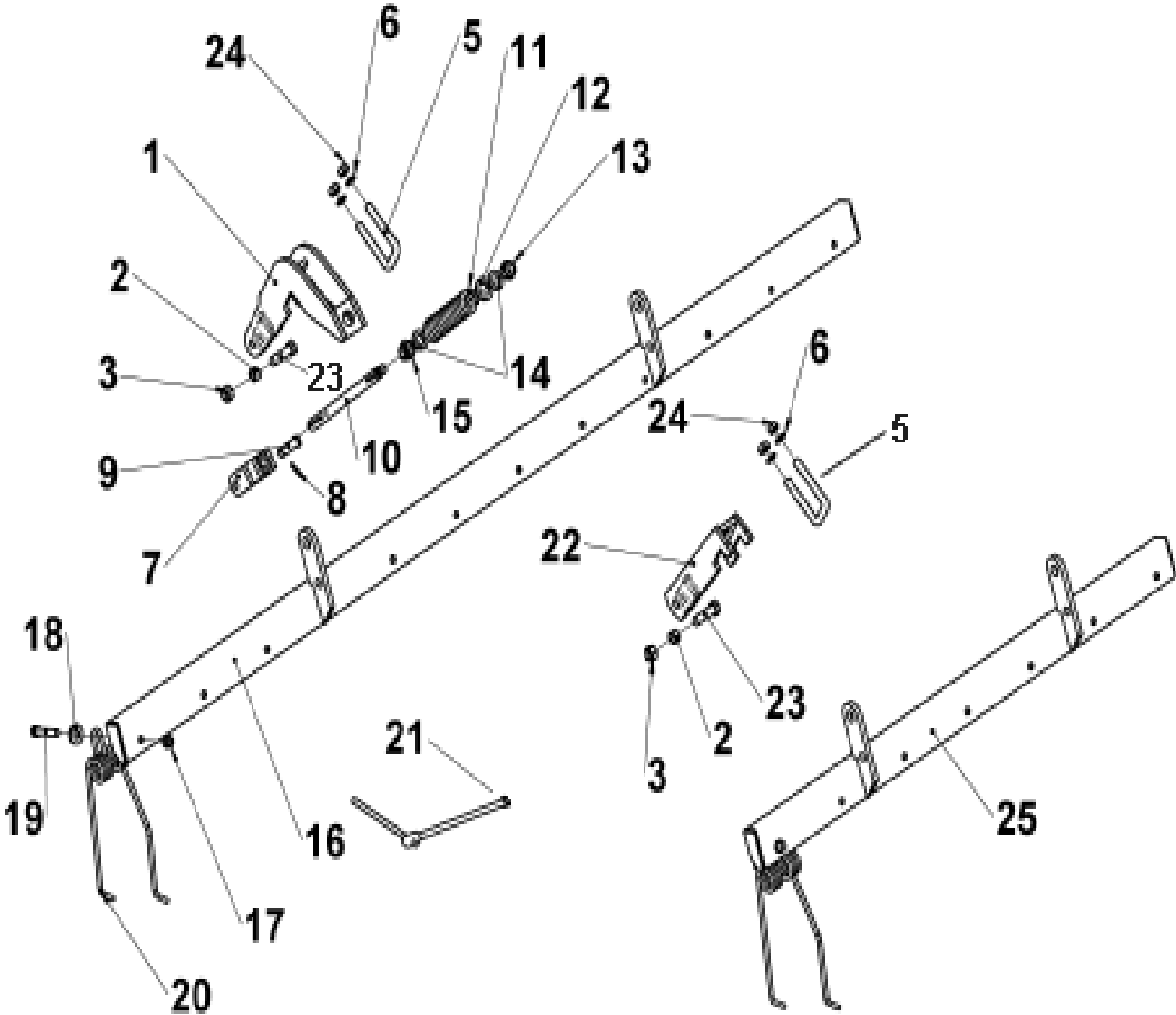

SPARE PARTS

Draw	Code
1	PS-061352
2	ME-061301
3	985 16
5	EE-050314
6	127 14 BI
7	PS-061318
8	94 5x25 BI
9	BU-050303
10	ME-061305
11	ML-050300
12	ME-061303
13	985 20
14	125 20 BI
15	935 20 BI
16	PS-061361
17	985 12
18	ME-080202
19	931 12X70 8.8 B
20	M01-51/B
21	PS-061374
22	PS-061305/D/I
23	931 16x55 8.8 B
24	934 14 BI
25	PS-061362
	PS-061365/D
	PS-061365/I
	PS-061364/D
	PS-061364/I
	PS-061363/D
	PS-061363/I

9.23 TRACK ERASERS

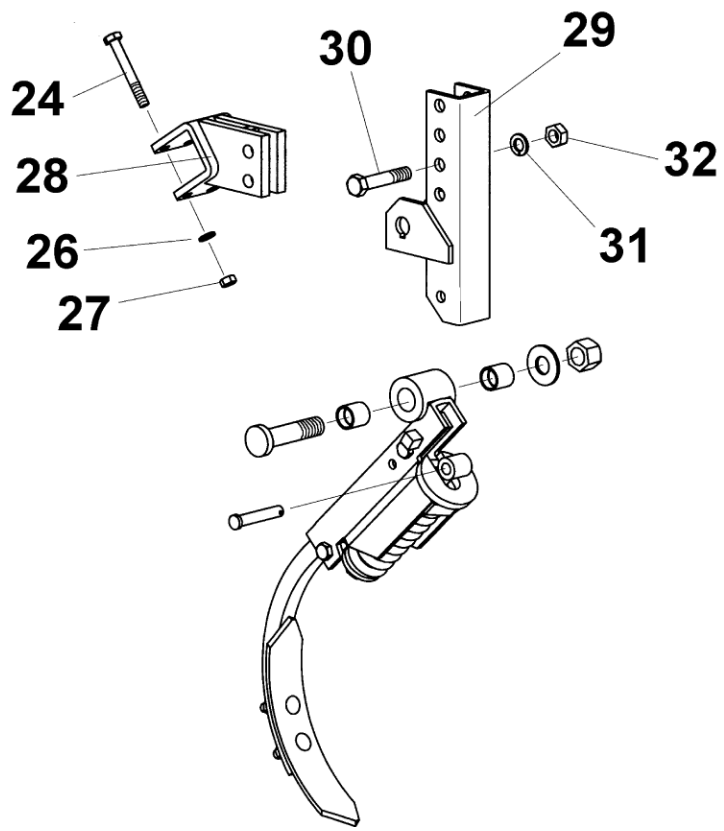
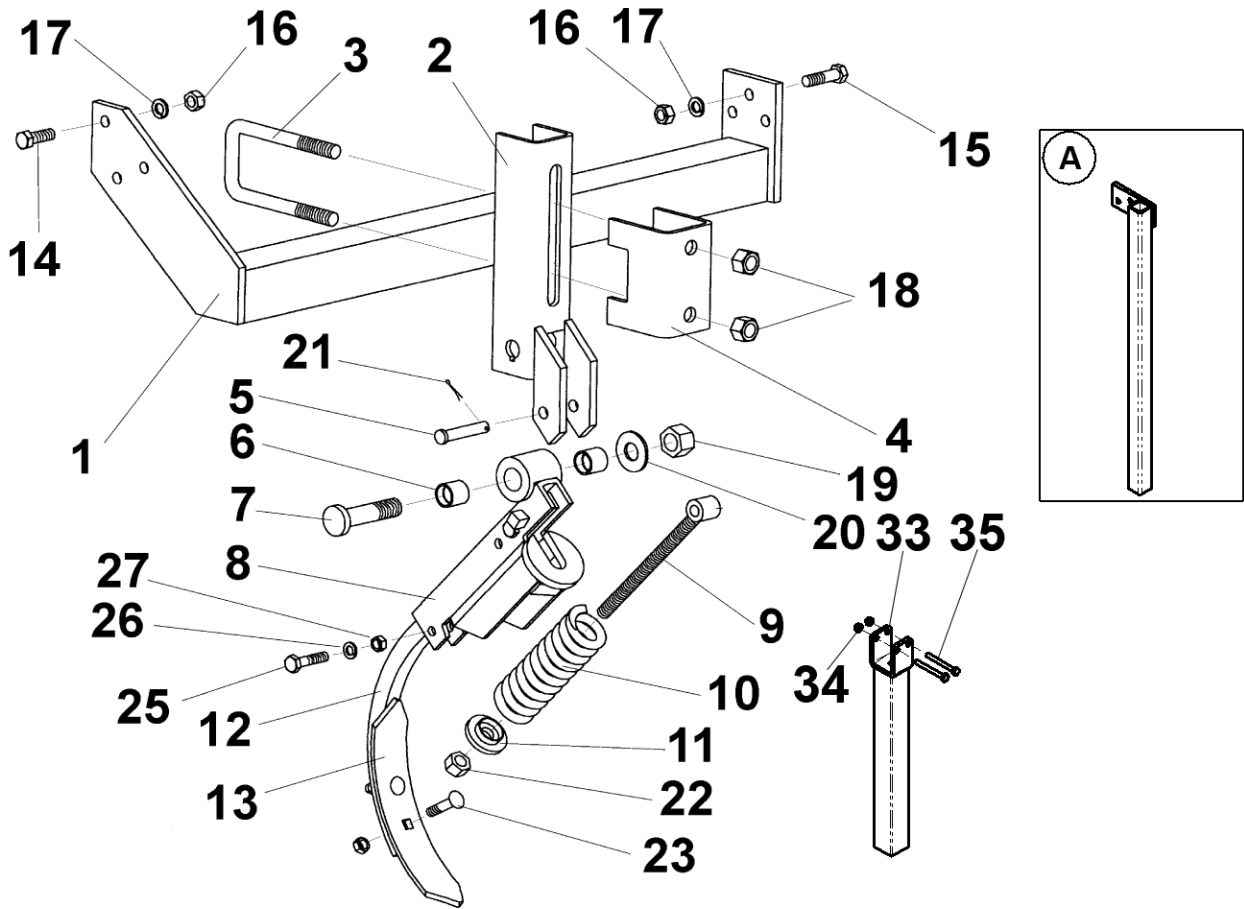

Drw	Code
1	PS-061366/D
1	PS-061366/ I
2	PS-1113
3	EE-060228
4	PX-060201
5	BU-060300
6	PL-050302
7	EE-050312
8	PS-1120
9	FO-060202
10	ML-060300
11	PS-1115
12	FO-060302
13	FO-060300
14	933 12X35 8.8 B
15	933 12X45 8.8 B
16	934 12 BI
17	127 12 BI
18	985 16
19	985 2/15
20	125 20 BI
21	94 3,5X 20 BI
22	985 14
23	608/934 9X40
24	931 10X80 8.8 B
25	931 10X45 8.8 B
26	127 10 BI
27	934 10 BI
28	PS-061322
29	PS-061330
30	931 14X70 8.8 B
31	127 14 BI
32	934 14 BI
33	PS-071320
34	985 10
35	931 10X90 8.8 B
<hr/>	
	S/BH
<hr/>	
A	PS-071321/D PS-071321/I

9.24 HARROW

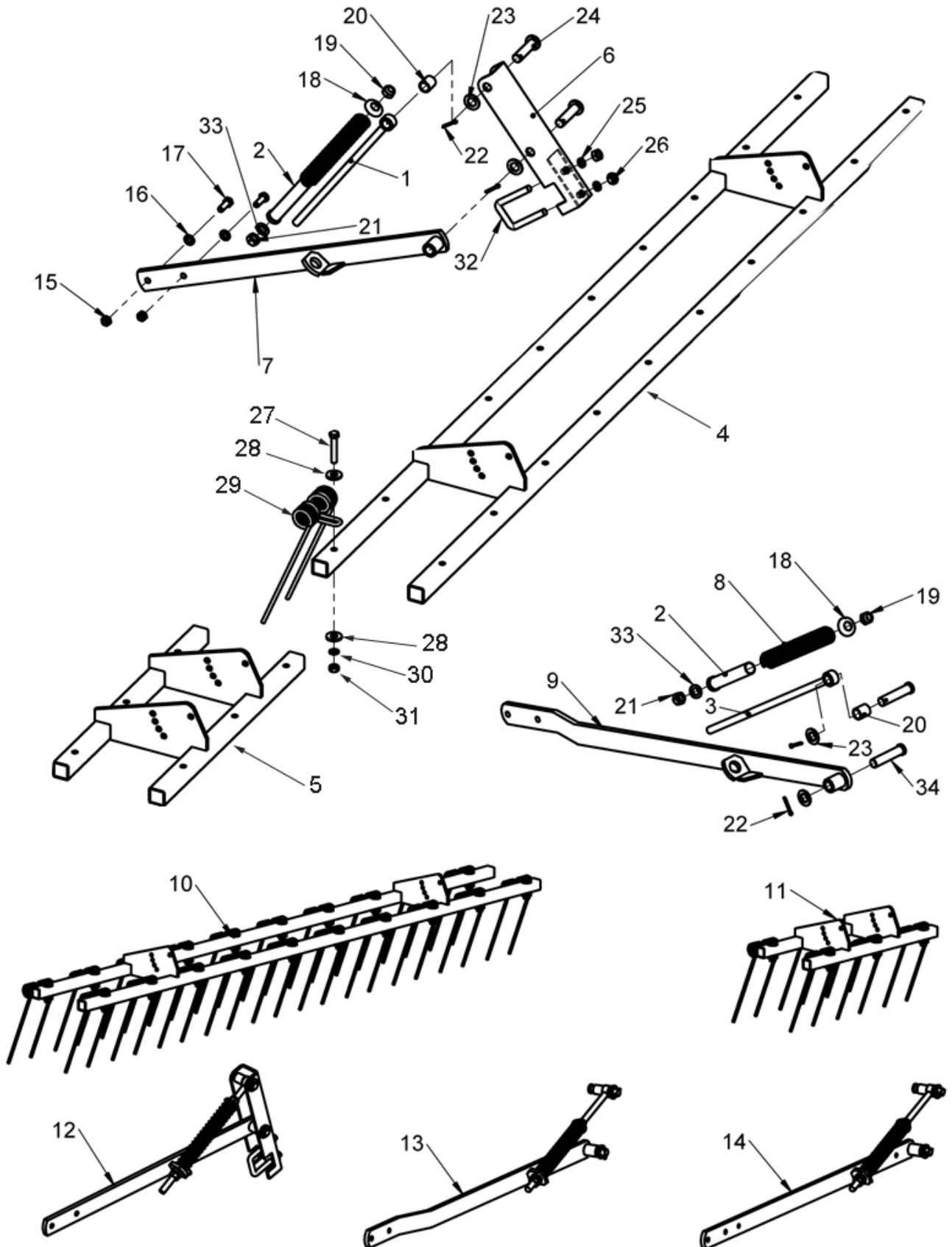

Draw	Code
1	PS-1710
2	PS-1735
3	PS-2244
4	PS-081306
5	PS-081307
	PS-081308
	PS-081309
	PS-081313
6	PS-081310
7	PS-081311-D
	PS-081311-I
8	ML-080104
9	PS-081319-D
	PS-081319-I
10	MO-081303
11	MO-081300
	MO-081301
	MO-081302
	MO-081306
12	MO-081305-D
	MO-081305-I
13	MO-081307/D
	MO-081307/I
14	MO-081308/D
	MO-081308/I
15	985 12
16	125 12 BI
17	933 12X35 8.8B
18	T08-23
19	985 16
20	CT-081305
21	934 16 BI
22	94 5X32 BI
23	125 20 BI
24	B03-177
25	7980 14 BI
26	934 14 BI
27	931 12X70 8.8B
28	ME-080202
29	M01-83
30	127 12 BI
31	934 12 BI
32	EE-050314
33	125 16 BI
34	BU-070601

9.25 TRACK MARKERS

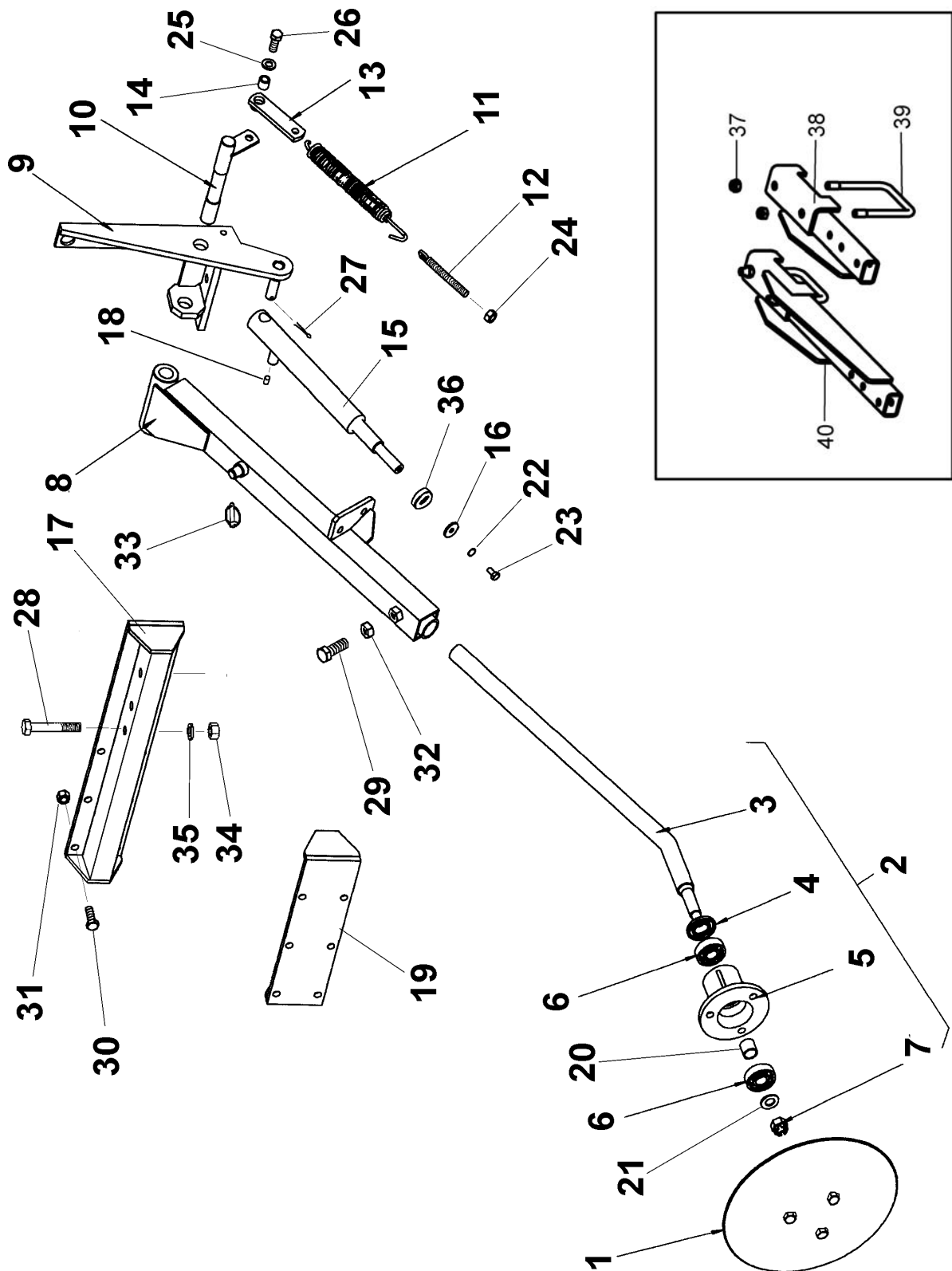

SPARE PARTS

Draw	Code
1	EE-100217
2	RE-100300
3	PR-100201
4	FE-601000
5	ME-100214
6	FE-600005
7	935 16 BI
8	PS-1815/d
9	PS-101303/D
10	PS-101304
11	ML-050201
12	EE-100219
13	PS-1805
14	ME-100200
15	CO-101300
16	EE-030200
17	PS-101302
18	ME-100210
19	PS-101301
20	CT-100800
21	125 16 BI
22	127 8 BI
23	933 8X15 BI
24	985 12/150
25	125 12 BI
26	933 12X30 BI
27	94 5X32 BI
28	931 14X80 8.8 B
29	933 16X45 8.8 B
30	933 12X35 8.8 B
31	985 12
32	934 16 BI
33	FE-610006
34	934 14 BI
35	7980 14 BI
36	CT-100302
37	985 16
38	PS-101362
39	EE-101349
40	PS-101361

9.26 PRE-EMERGENCE TRACK MARKERS

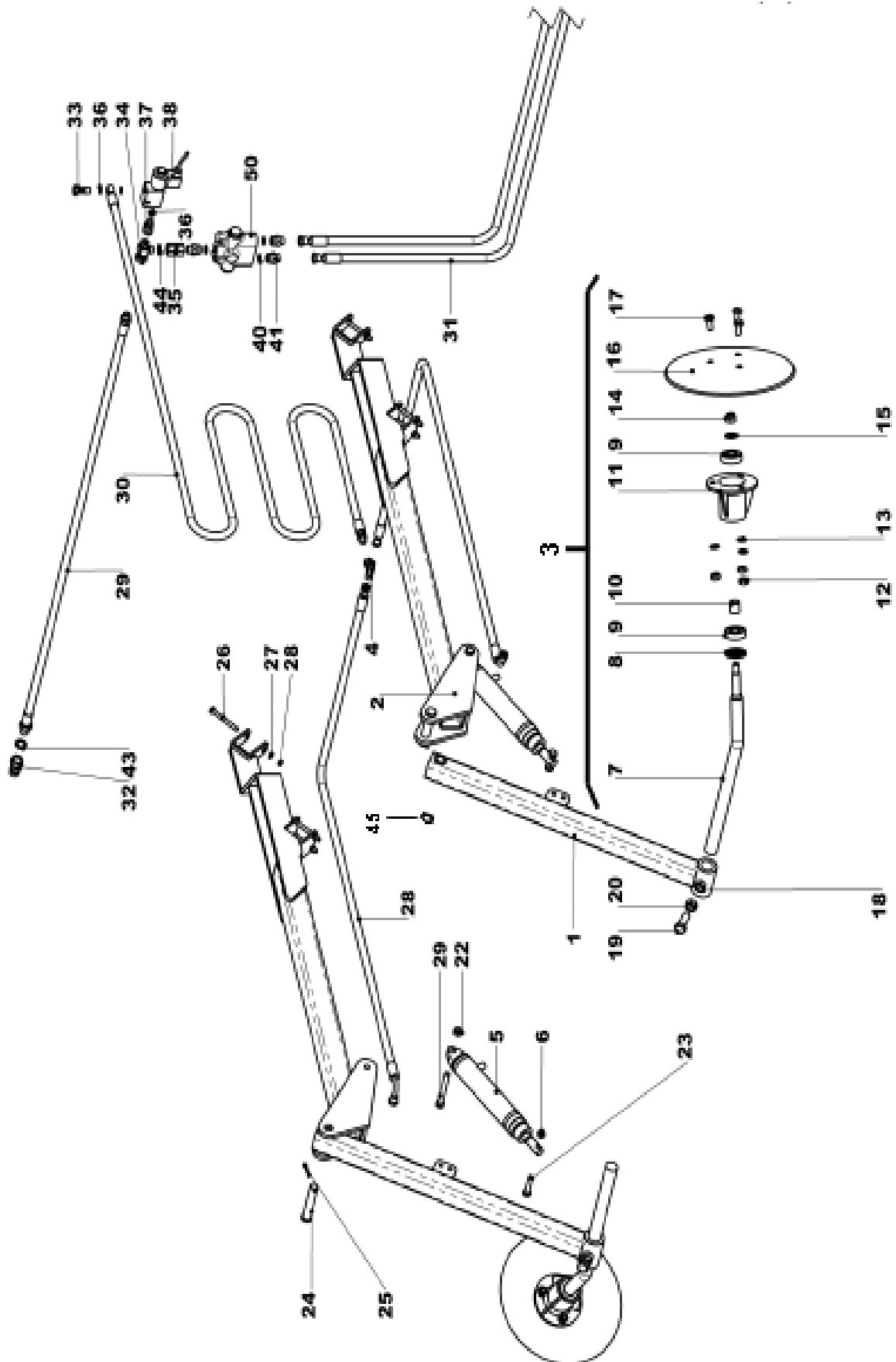

SPARE PARTS

Draw	Code
1	PS-101343
2	PS-101352
3	MO-101329
4	HI-703010
5	CO-045101
6	985 10
7	PR-101302
8	FE-601000
9	FE-600005
10	CT-100800
11	B07-30
12	934 12 BI
13	127 12 BI
14	985 16
15	125 16 BI
16	EE-100217
17	933 12X25 8.8B
18	934 16
19	933 16X45 8.8B
20	934 16 BI
21	931 12X95 8.8B
22	985 12
23	931 10X50 8.8B
24	B03-188
25	94 5X32 BI
26	931 8X80 8.8B
27	127 8 BI
28	934 8 BI
29	HI-700065
30	HI-700147
31	HI-700175
	HI-700159
	HI-700145
32	HI-701000
33	HI-702000
34	HI-703005
35	HI-704019
36	HI-705001
37	HI-704047
38	HI-706017
39	HI-706013
40	3770 14.25
41	HI-704030
42	HI-700045
43	HI-705002
44	HI-705003
45	125 20 BI

9.27 TRACK MARKERS 6 MTS

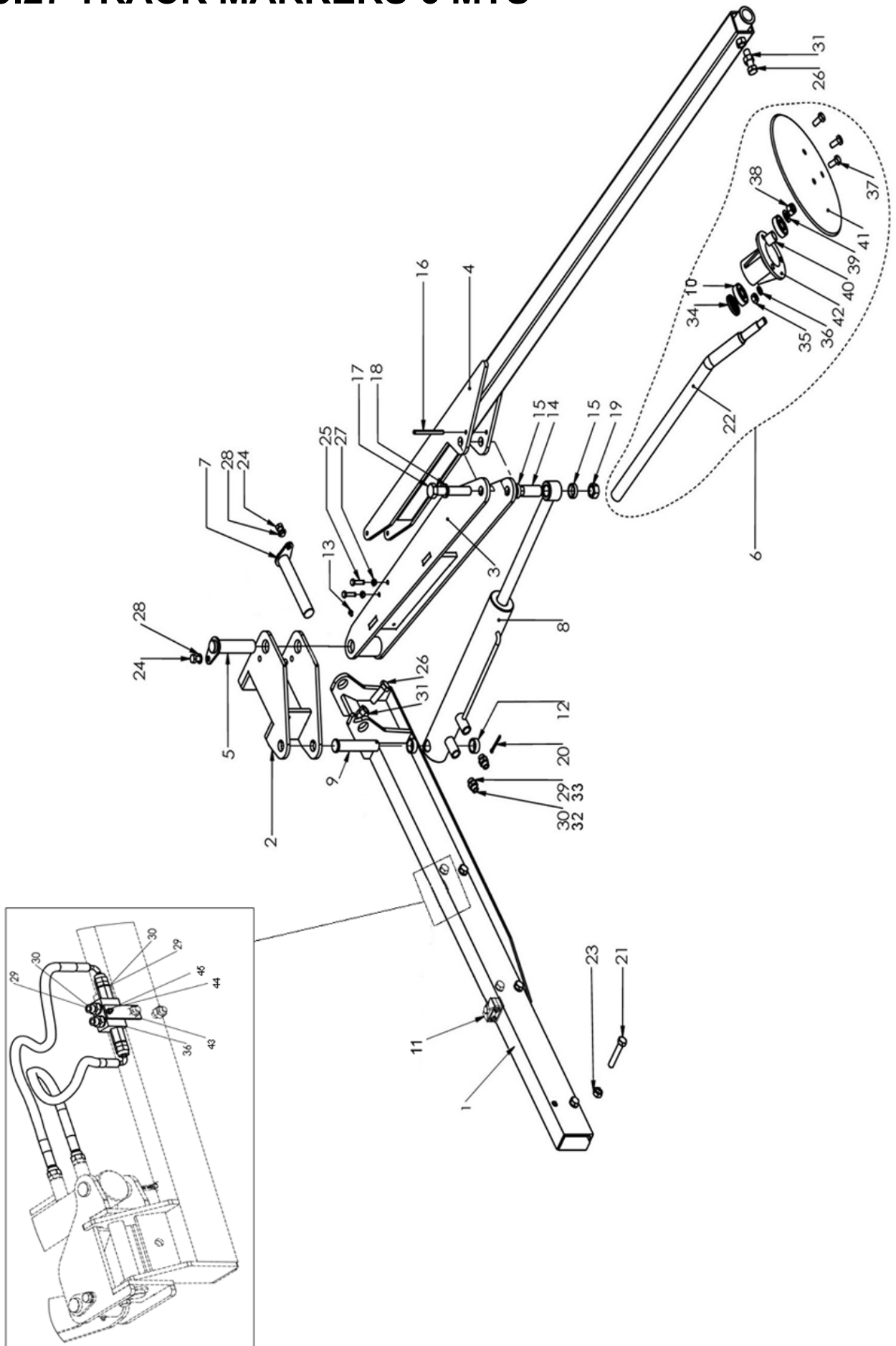

Draw	Code
1	PS-101359-D-I
2	PS-101356-D-I
3	PS-101355
4	PS-101354
5	PS-101357
6	MO-1801
7	PS-101358
8	CO-051300
9	BU-051301
10	FE-600005
11	HI-708001
12	CT-101351
13	FE-603001
14	ME-101329
15	CT-101355
16	1481 8X100 BI
17	931 20X120 8.8 BI
18	7980 20 BI
19	934 20 BI
20	94 5X36 BI
21	931 14x80 8.8
22	PR-100201
23	985 14
24	933 12X20 8.8 BI
25	933 8x30 8.8 B
26	933 16X50 8.8B
27	985 8
28	127 12 BI
29	HI-705003
30	HI-704007
31	934 16
32	HI-700189
33	HI-700187
34	FE-601000
35	934 12 BI
36	HI-706001
37	933 12X25 8.8B
38	985 16
39	125 16 BI
40	CT-100800
41	EE-100217
42	B07-30
43	PX-101365
44	985 6
45	931 6X45 8.8 B

9.28 TRACK MARKERS 6 MTS/DISCS

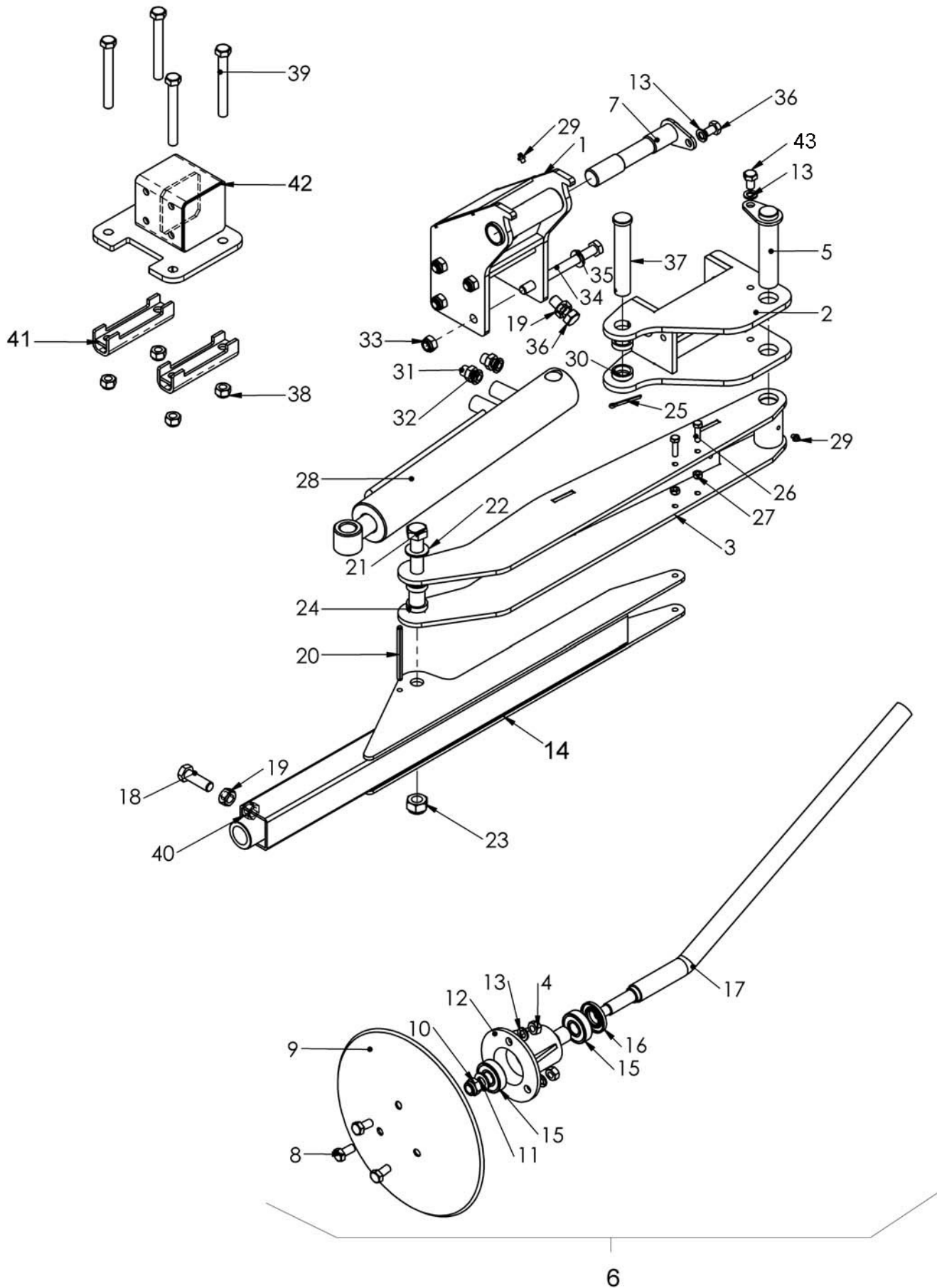

Drw	Code
1	PS-102201
2	PS-101356/D
3	PS-101355
4	934 12 BI
5	PS-101357
6	MO-1801
7	PS-102202
8	933 12X25 8.8B
9	EE-100217
10	985 16
11	125 16 BI
12	B07-30
13	127 12 BI
14	PS-101360
15	FE-600005
16	FE-601000
17	PR-100201
18	933 16X50 8.8B
19	934 16 BI
20	1481 8X100 BI
21	931 20X120 8.8B
22	125 20 BI
23	985 20
24	CT-101355
25	94 5X45 BI
26	933 8X30 8.8B
27	985 8
28	CO-051300
29	FE-603001
30	CT-101351
31	HI-705003
32	HI-704007
33	985 14
34	931 14X160 8.8B
35	125 14 BI
36	933 16X40 8.8B
37	BU-051301
38	985 18
39	931 18X150 8.8B
40	934 16
41	PS-050617
42	PS-101365
43	933 12X20 8.8B

9.29 FINISH

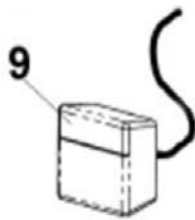
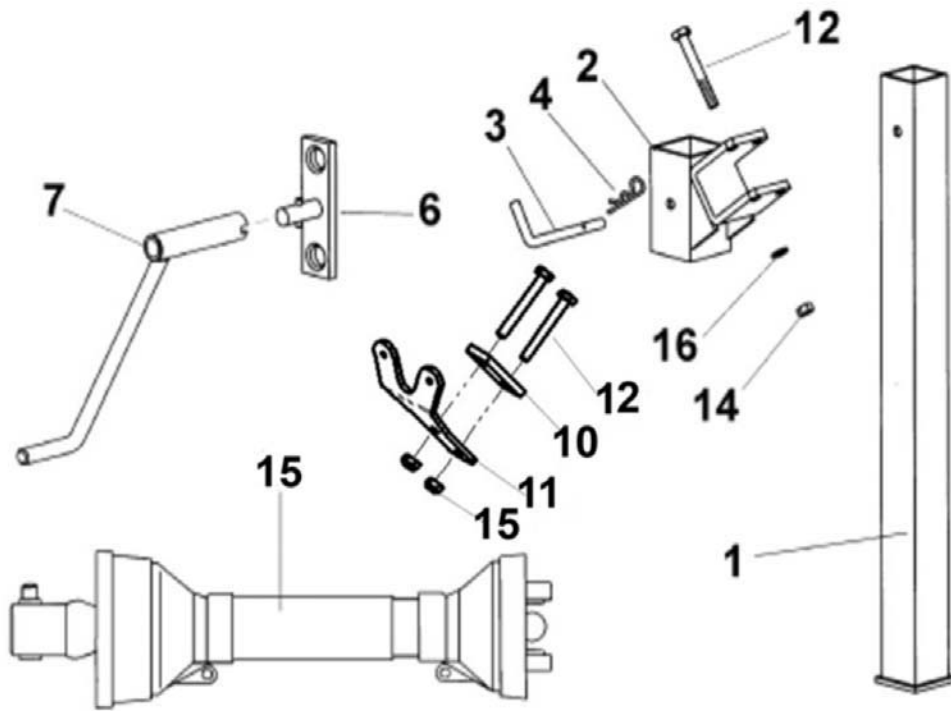

13=5+9

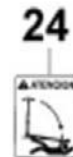
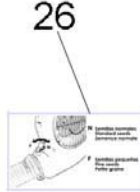
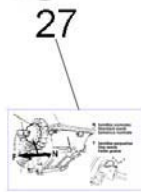
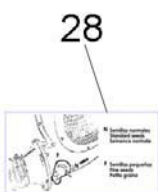
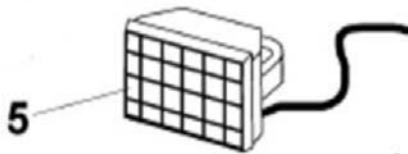

Drw	Code
1	PS-071310
2	PS-071309
3	TA-071305
4	FE-610002
5	MV-071301/05
6	PS-041312
7	CO-070300
8	AD-075104
9	MV-071302
10	EE-101312
11	PX-101373
12	931 10X80 8.8 B
13	MV-071300
14	934 10 BI
15	FE-608006
16	127 10 BI
17	AD-071302
18	AD-070214
19	AD-070207
20	AD-070215
21	AD-070222
22	AD-070206
23	AD-070227
24	AD-100200
25	AD-071307
26	AD-041302
27	AD-041304
28	AD-041303

9.30 PLATFORM

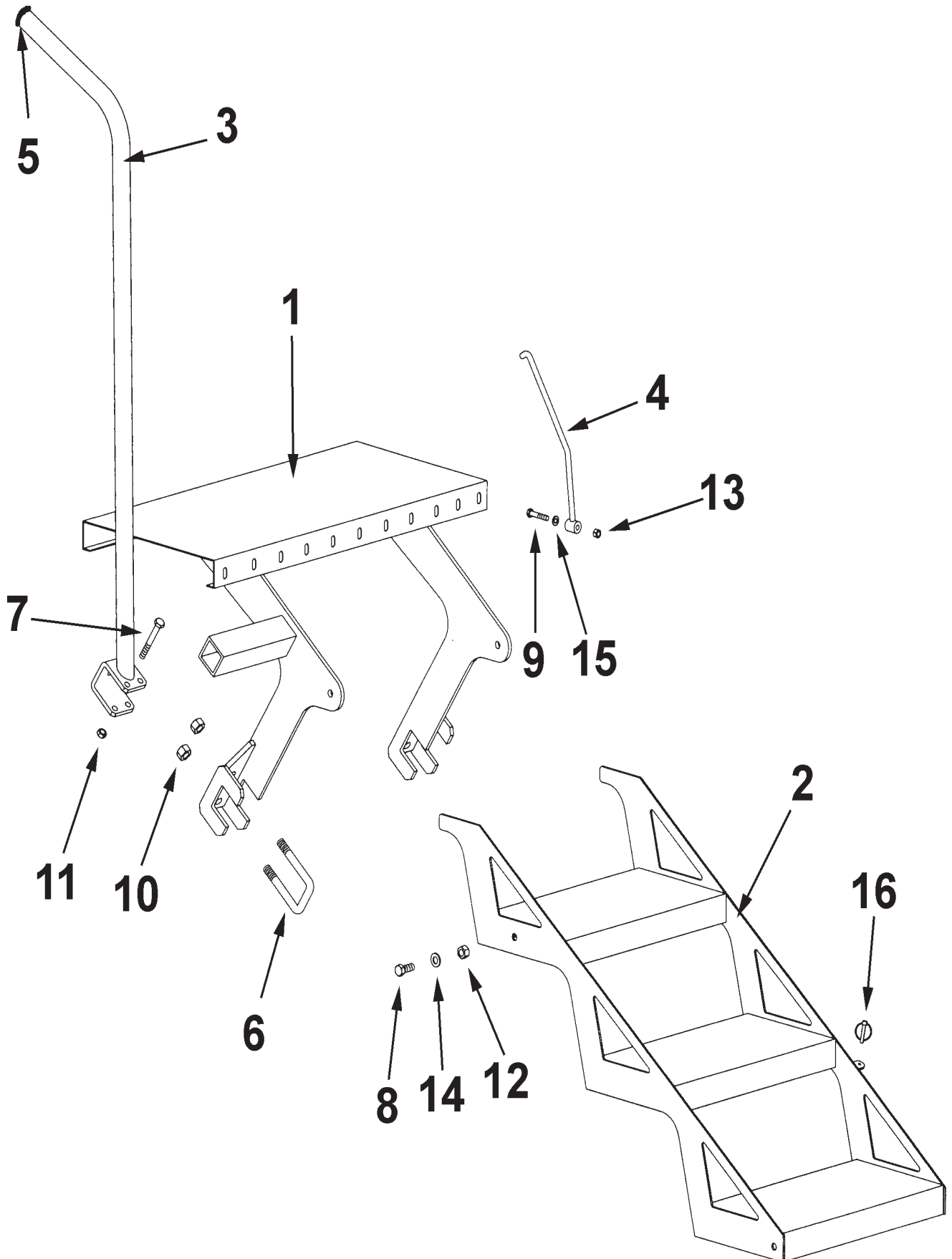

Draw	Code
1	PS-071316
2	PS-071314
3	PS-071311 PS-071312
4	PS-071317
5	CN-817002
6	EE-050314
7	931 10X80 8.8 B
8	933 12X30 8.8 B
9	931 8X45 8.8 B
10	985 14
11	985 10
12	985 12
13	985 8
14	125 12 BI
15	125 8 BI
16	FE-615005

9.31 STAIRS FOR RETAR CULTIVATOR

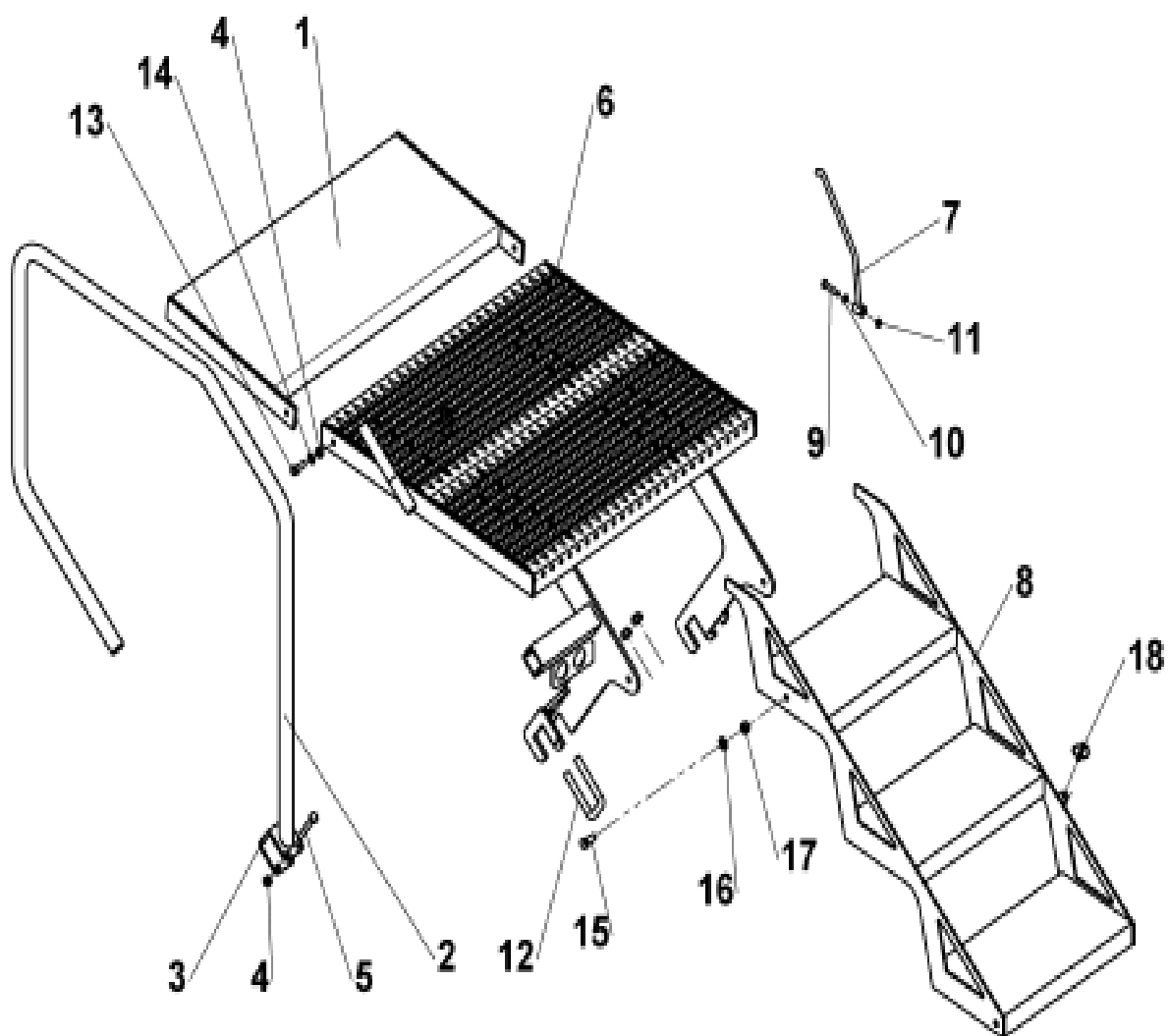

Draw	Code
1	PS-071322
2	PS-071323
3	B10-16
4	985 10
5	931 10x80 8.8 B
6	PS-071318
7	PS-071317
8	PS-071314
9	931 8x45 8.8 B
10	125 8 BI
11	985 8
12	EE-050314
13	933 10x30 8.8 B
14	125 10 BI
15	933 12X30 8.8 B
16	125 12 BI
17	985 12
18	FE-610005

9.32 STAIRS FOR ARMS BAR OF THE DISCS

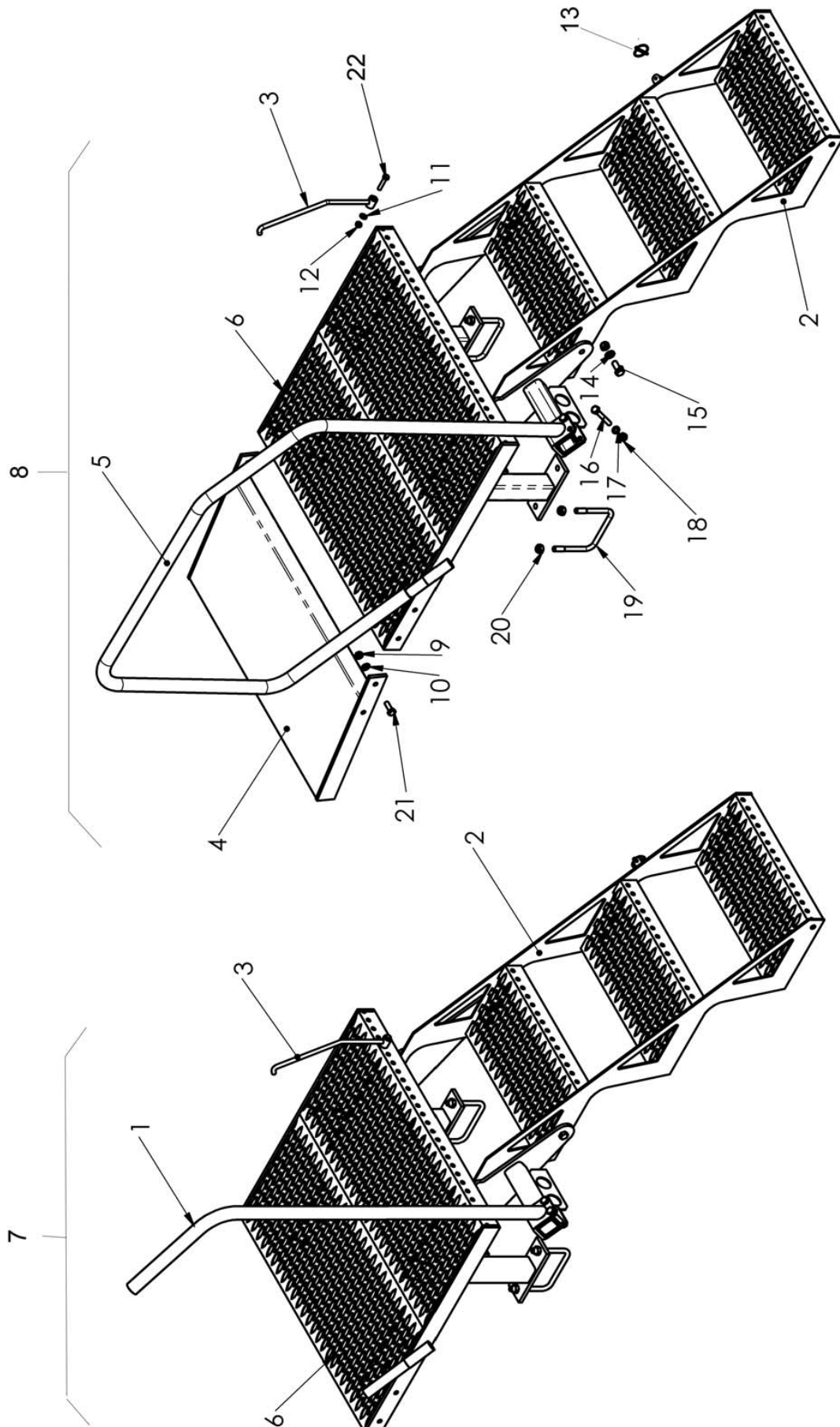

Drw	Code
1	PS-071312
2	PS-071314
3	PS-071317
4	PS-071322
5	PS-071323
6	PS-071324
7	MO-171319
8	MO-171320
9	985 10
10	125 10 BI
11	125 8 BI
12	985 8
13	FE-610005
14	125 12 BI
15	933 12X30 8.8B
16	931 10X80 8.8B
17	127 10 BI
18	934 10 BI
19	EE-071326
20	985 12
21	933 10X30 8.8B
22	931 8X40 8.8B

9.33 SHUT-OFF VALVES

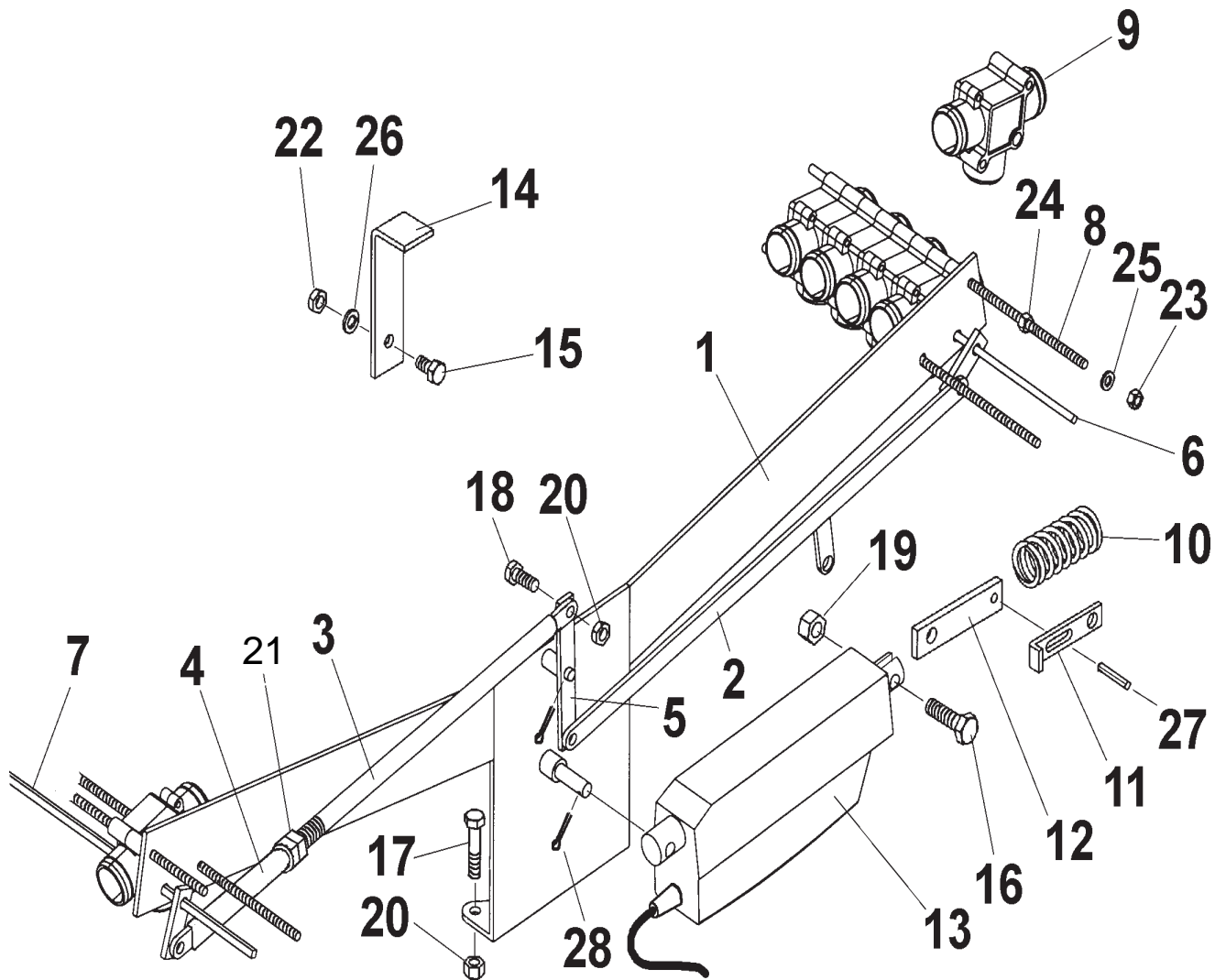

SPARE PARTS

Draw	Code
1	PS-101309
2	PS-101308
3	EE-101317
4	CO-101303
5	EE-101314
6	PS-101313
6	PS-101314
6	PS-101315
6	PS-101325
6	PS-101339/D
7	PS-101310
7	PS-101311
7	PS-101312
7	PS-101339/I
8	CT-101309
8	CT-101310
8	CT-101311
	CT-101342
9	MO-041305
10	ML-101301
11	PX-101318
12	EE-101325
13	CO-101301
14	EE-101320
15	933 8X15 8.8 B
16	933 10X35 8.8 B
17	933 8X25 8.8 B
18	933 8X20 8.8 B
19	985 10
20	985 8
21	934 12/150 BI
22	934 8 BI
23	985 6
24	934 6 BI
25	125 6 BI
26	127 8 BI
27	1481 6X30 BI
28	94 3X20 BI

9.34 OPTIONAL EQUIPMENT CONTROL MONITORS

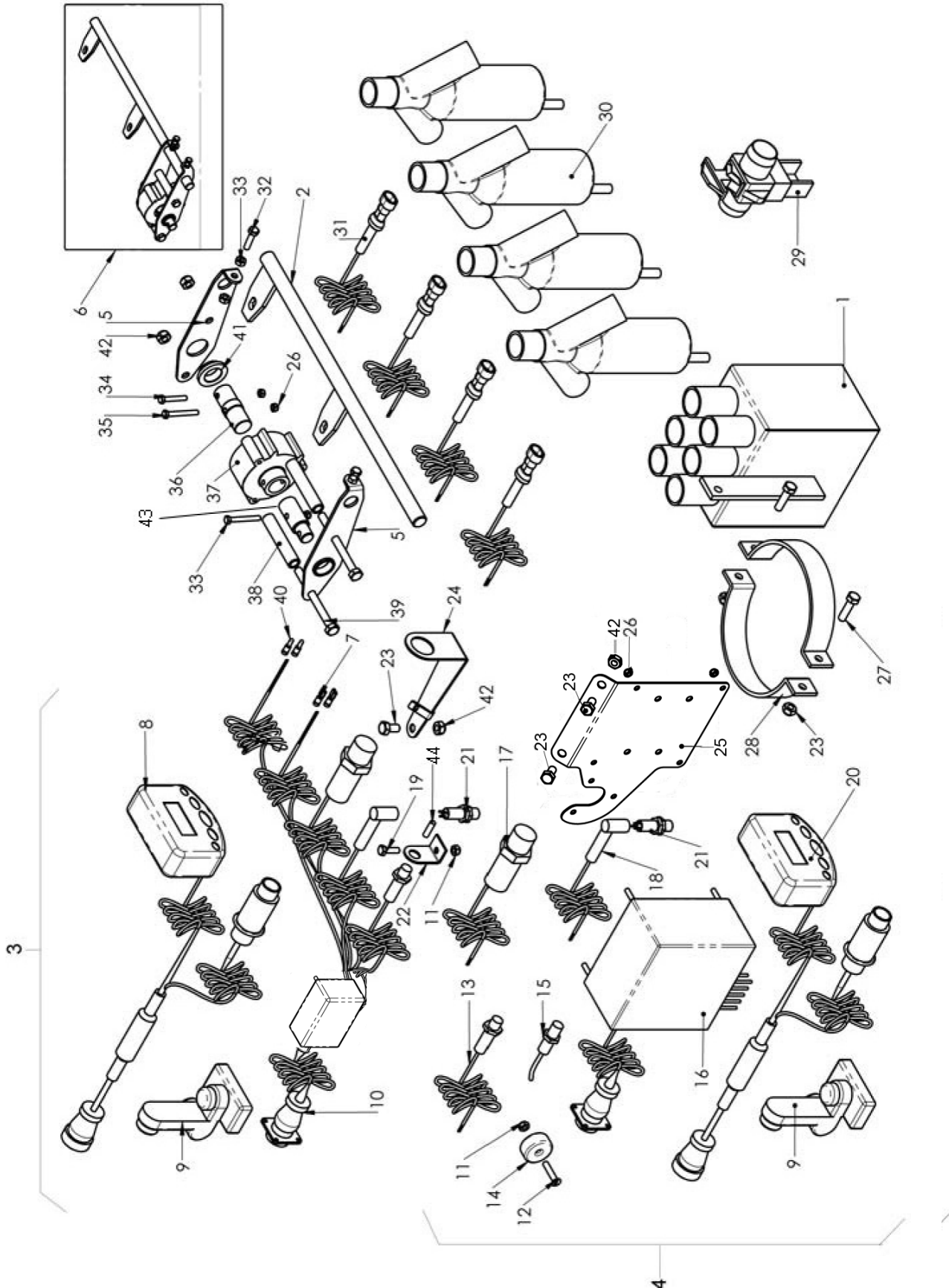

Draw	Code
1	PS-101347
2	PS-101366
3	MV-101316
4	MV-101320
5	MO-101331
6	EO-101353
7	FE-650017
8	MV-101316-01
9	MV-101316-02
10	MV-101316-03
11	985 6
12	963 6x30 8.8 B
13	FE-650027
14	MV-101320-06
15	FE-650008
16	MV-101320-02
17	FE-650026
18	MV-101320-05
19	933 6X20 8.8B
20	MV-101320-01
21	FE-650025
22	PX-101311
23	933 8X16 8.8B
24	PX-101358
25	PX-101357
26	985 5
27	933 8X30 8.8B
28	EE-101324
29	KV-490788
30	MV-101325
31	CN-803285
	CN-803286
	CN-803287
	CN-803288
32	933 6X25 8.8B
33	934 6 BI
34	931 5X30 8.8B
35	931 5x40 8.8B
36	ME-101334
37	MV-100603
38	ME-101335
39	931 8X90 8.8B
40	FE-650015
41	PL-020204
42	985 8
43	ME-101333
44	FE-650014

