

PROSEM

Planter Metering Units K and P

STARTING MANUAL MAINTENANCE DOSAGE

Please read and follow this operating manual before putting the machine into operation.



SOLÀ seed drills, planters and fertilizer spreaders are manufactured in a highly specialized environment and our factory has a vast network of satisfied customers.

SOLÀ machines use highly advanced technology and are guaranteed to work without malfunctions in a large variety of conditions. The **SOLÀ** machines are provided with easy-to-use and efficient devices and perform excellently with only minimum operator maintenance.

This manual will help you use your **SOLÀ** product with the maximum efficiency.



Certified quality system

4th Edition – Novembre 2022

Ref.: CN-811036/GB

Created by: M.A. SOLÀ

It is forbidden to copy any part of this manual.

Specifications are subject to change or modification without notice.

The pictures included do not necessary show the standard version.

TABLE OF CONTENTS

1- INTRODUCTION.....	5
2- SAFETY INSTRUCTIONS	6
2.1 SAFETY SYMBOLS.....	6
2.2 GENERAL SAFETY REGULATIONS	7
2.3 LOADING AND UNLOADING INSTRUCTIONS	7
2.4 SAFETY ELEMENTS.....	8
3. OVERVIEW	9
3.1 PLANTER OVERVIEW	9
3.2 MACHINE IDENTIFICATION	10
3.3 USE ACCORDING TO DESIGN	10
3.4 METERING UNIT PROSEM K.....	10
3.5 METERING UNIT PROSEM P.....	11
3.6 METERING BOX.....	12
3.7 FRAMES	13
3.7.1 FIXED	13
3.7.2 VARIANT MANUAL FIXED.....	13
3.7.3 TELESCOPIC	14
3.7.4 VARIANT	14
3.7.5 VARIANT IDRA	14
3.7.6 FOLDING FRAME.....	14
3.8 ELECTRICAL DIAGRAMS	15
4. TECHNICAL CHARACTERISTICS	16
5. STARTING	22
5.1 COUPLING TO THE TRACTOR	22
5.2 CONNECTING AND ADAPTING THE PTO SHAFT	23
5.3 PLANTING ADJUSTMENTS	24
6. ADJUSTMENTS	25
6.1 PLANTING DISTANCE BETWEEN SEEDS	25
6.1.1 CHAIN GEARBOX.....	31
6.1.2 AUTOMATIC GEARBOX	31
6.2 REPLACING THE SEED DISC.....	32
6.3 SEED DISTRIBUTION IN THE SEED DISC.....	33
6.3.1 ADJUSTING THE SELECTOR.....	33
6.3.2 ADJUSTING THE SEED EJECTOR.....	34
6.3.3 SEED'S INLET TO THE METERING BOX	34
6.4 SUCTION SYSTEM – FAN	35
6.4.1 VACUUM CONTROL FOR MECHANICAL FAN (OPTIONAL).....	36
6.4.2 PNEUMATIC TRANSPORT OF THE FERTILIZER.....	36
6.5 ROW SPACING	37
6.5.1 FIXED MACHINE	37
6.5.2 VARIANT MANUAL FIXED MACHINE.....	37
6.5.3 TELESCOPIC MACHINE	38
6.5.3.1 TELESCOPIC HYBRID.....	39
6.5.4 VARIANT MACHINE	39
6.5.4.1 VARIANT V300/6 45-75 AND V300/6 50-80	39
6.5.4.2 VARIANT V300/6 4F95 6F50-75.....	40
6.5.4.3 VARIANT V300/6 4F95 6F70-80	40
6.5.4.4 VARIANT V300/7 7F45-60 6F70-80	41
6.5.4.5 VARIANT V300/7-S 50-80.....	42
6.5.5 VARIANT IDRA MACHINE.....	42
6.5.5.1 IDRA300/8 40-75 AND IDRA330/8 45-80.....	42
6.5.5.2 IDRA300/9 9F40-55 8F65-75 AND IDRA330/9 9F45-60 8F70-80	43
6.5.6 FOLDING MACHINE.....	44
6.5.6.1 FIXED FOLDING MACHINE.....	44
6.5.6.2 VARIANT MANUAL FIXED FOLDING MACHINE.....	44
6.5.6.3 TELESCOPIC FOLDING MACHINE	44
6.5.6.4 IDRA FOLDING MACHINE.....	44
6.5.6.5 GEA FOLDING MACHINE.....	44
6.6 DRIVE WHEELS.....	44
6.6.1 FRONT DRIVE WHEELS, FIXED IN HEIGHT	44
6.6.2 REAR DRIVE WHEELS, ADJUSTABLE IN HEIGHT	45
6.7 EXCLUDING A METERING UNIT	45
6.7.1 MANUAL EXCLUSION OF THE TRANSMISSION	45
6.7.2 AUTOMATIC ROW EXCLUSION (OPTIONAL).....	45
6.7.3 RAISING THE UNIT	46

TABLE OF CONTENTS

6.8 PLANTING DEPTH	47
6.8.1 ADJUSTING PROSEM K	47
6.8.2 ADJUSTING PROSEM P	47
6.9 SCRAPER PROSEM K.....	47
6.10 PRESSURE OF THE METERING UNIT ON THE GROUND.....	48
6.10.1 PRESSURE OF THE METERING UNIT K/P.....	48
6.10.1.1 LEVER SYSTEM	48
6.10.1.2 SPINDLE SYSTEM.....	48
6.10.2 PRESSURE OF THE BASIC UNIT	49
6.11 CLOSING THE FURROWS	49
6.11.1 V-SHAPED PRESS WHEELS – PROSEM K.....	49
6.11.1.1 WHEEL'S WORKING WIDTH.....	50
6.11.1.2 PRESSURE ONTO THE SEED.....	50
6.11.1.3 BEARING ANGLE.....	50
6.11.2 FURROW-COVERER – PROSEM P.....	51
6.11.2.1 ADJUSTING THE FURROW-COVERER PROSEM P HIGH SHARE	51
6.11.2.2 ADJUSTING THE FURROW-COVERER PROSEM P	51
6.12 OPENING COMPONENTS	52
6.12.1 ADJUSTING THE BLADE AND THE CLOD REMOVER	52
6.12.2 ADJUSTING THE DISC FURROW OPENER IN UNIT PROSEM K (OPTIONAL)	52
6.12.3 ADJUSTING THE FURROW-OPENER BLADE (OPTIONAL)	53
6.12.4 ADJUSTING THE FURROW'S RESIDUE ROTARY CLEANER IN PROSEM K METERING UNITS (OPTIONAL)	53
6.13 FURROW'S RESIDUE ROTARY CLEANERS WITH PARALLELOGRAM (OPTIONAL)	54
6.14 TURBO DISC OPENER (OPTIONAL).....	54
6.15 SEED PRESSING WHEEL PROSEM K (OPTIONAL).....	55
6.16 TRACK ERASER (OPTIONAL).....	56
6.17 HYDRAULICAL TRACK MARKERS	56
6.17.1 ADJUSTING TRACK MARKER'S LENGTH	57
6.17.2 ADJUSTING TRACK DISC'S ORIENTATION.....	57
6.18 FERTILISING EQUIPMENT (OPTIONAL)	58
6.18.1 REPLACING THE FERTILISER'S TRANSMISSION	60
6.18.2 FERTILISER'S DOUBLE DISC.....	61
6.18.3 FERTILISER'S SHARE	61
6.18.4 FERTILIZERS ON PLANTING ELEMENT (OPTIONAL)	62
6.19 MICRO GRANULAR FERTILIZER (OPTIONAL)	62
6.19.1 CHANGING THE MICROGRANULATOR'S TRANSMISSION	65
6.19.2 EXCLUDING THE MICRO GRANULATOR.....	65
6.20 MICRO GRANULAR PESTICIDE (OPTIONAL)	66
6.21 MICRO GRANULAR FERTILIZER AND MICRO GRANULAR PESTICIDE (OPTIONAL).....	69
6.21.1 CHANGING THE TRANSMISSION OF THE MICRO GRANULAR FERTILIZER WITH DOUBLE HOPPER.....	73
6.21.2 CHANGING THE TRANSMISSION OF THE MICRO GRANULAR PESTICIDE WITH DOUBLE HOPPER.....	73
6.21.3 EXCLUDING THE FERTILIZER AND MICRO GRANULAR PESTICIDES	74
7. TRANSPORT	75
7.1 FIXED FRAME	75
7.2 VARIANT MANUAL FIXED FRAME.....	75
7.3 TELESCOPIC, VARIANT AND VARIANT IDRA FRAME	75
7.4 FOLDING FRAME.....	76
8. FILLING AND EMPTYING THE HOPPERS	77
8.1 SEED HOPPER.....	77
8.2 FERTILISER HOPPER.....	77
8.3 MICRO GRANULAR FERTILIZER'S AND/OR MICRO GRANULAR PESTICIDE'S HOPPERS	77
9. MAINTENANCE	78
9.1 CHECKING FREQUENCY.....	78
9.2 GREASING AND LUBRICATION	79
9.3 FANS.....	80
9.4 TRANSMISSION CHAIN.....	80
9.5 AUTOMATIC GEARBOX.....	81
9.6 MACHINE CLEANING	81
9.7 SCREWS	82
9.8 TYRE PRESSURE	82

1- INTRODUCTION

It is essential to read and follow the instructions and recommendations in this manual before operating **the precision planter PROSEM**. Careful reading enables maximum operator efficiency, prevents accidents and damage, and increases the planter's capacity and life expectancy.

Please ensure that this manual has been read by any person involved in performing **operational tasks**, (including preparation, dealing with mechanical problems and supervising the machine), **maintenance** (inspection and technical assistance) and **transport**.

For your safety, please follow these technical safety instructions as **SOLÀ** will not be responsible for damages caused by not observing the information provided.

In the first chapters you will find the Technical Characteristics and Safety Instructions. Basic concepts that are required to operate the machine are explained in the Starting, Adjusting and Maintenance sections.

The last part of this manual consists of Dosage Tables, detailed by all types of seed, fertilizer, micro granular fertilizer and micro granular pesticide.



SOLÀ RETAINS THE RIGHT TO MODIFY ILLUSTRATIONS, TECHNICAL DATA AND WEIGHTS INDICATED IN THIS OPERATING MANUAL, IF THESE CHANGES HELP TO IMPROVE THE QUALITY OF THE PLANTERS.

2- SAFETY INSTRUCTIONS

2.1 SAFETY SYMBOLS

In this operating manual you will find three different symbols relating to safety:



TO WORK MORE EASILY WITH THE PLANTER.



TO PREVENT DAMAGE TO THE PLANTER AND OPTIONAL EQUIPMENT.



TO PREVENT PHYSICAL INJURY.

On the machine you will find the following warning pictograms:



Read the instructions carefully and observe the safety advice given in the operating manual.



During the coupling maneuver, stay away from the rear part of the tractor. Check nobody stands in the operational area of the telescopic folding parts.
Risk of serious physical injury.



While maintaining or repairing the planter, stop the tractor's engine and prevent it from starting. The ignition key must be removed.



Risk of being crushed when working under the machine, please secure the machine to prevent this risk. **Risk of serious physical injuries.**



It is forbidden to ride on the machine during operation. **Risk of serious physical injuries caused by falling.**



Danger of infection from escaping hydraulic fluid at high pressure! This can inflict serious injuries with potentially fatal consequences if it passes through the skin and into the body. **Keep the hose lines in good condition. Risk of serious physical injuries.**



Never stand under the track markers nor inside their action area. **Risk of serious physical injury.**



Do not exceed maximum load



Coupling point for loading and unloading the machine by crane. See section 2.3 LOADING AND UNLOADING INSTRUCTIONS.



The parts signaled with this pictogram should be kept in good condition and greased. See section 9.2 GREASING AND LUBRICATION.



PTO's turning direction and speed (only in machines with mechanical fan).



2.2 GENERAL SAFETY REGULATIONS



- Before starting the machine, please check the machine is in good condition for work and is safe for road use.



- Check that visibility is clear around the machine and there is no person in the working area.



- In thoroughfare, please observe traffic signs and regulations.



- It is forbidden to ride on the machine or climb into the machine when it is running.



- Before using the machine, the user must be familiar with all operating elements.



- Please be extremely careful when coupling and uncoupling the machine to the tractor.



- Please check that the PTO shaft is in good condition and well protected. Prevent the protective tube from turning by holding both the tube and chain provided for this purpose.



- Mount the PTO shaft's transmission only when the tractor's engine is off.



- Before connecting the PTO shaft, be sure that the danger zone surrounding the machine is clear.



- Never leave the tractor's driver's seat while the machine is in operation.



- Do not deposit external elements inside the hopper.



- When maintaining the hydraulic system of the planter, make sure that it is depressurized and the tractor's engine is off.



- Please regularly check the condition of the tubes and hosepipes in the hydraulic system. These parts age naturally and their life should not surpass 6 YEARS. Please replace when necessary.



- Before transit with a machine with folding frame coupled to the tractor, check that the frame is completely folded.



- When raising the planter, the front axle is unloaded. Ensure that the machine has enough load to prevent it overturning. At this time you must ensure that the condition of both the steering and the brakes is optimal.



- During transit with the raised planter, block the lowering switch. Before leaving the tractor, lower the planter onto the ground and remove the tractor's starting key.



- Always use enough supporting elements when maintaining the machine in a raised position to prevent the machine from lowering or falling.



- Before starting to plant a field, evaluate the risks coming from the terrain: pronounced slopes, possible contact with high-voltage overhead lines due to an uneven ground or due to the position of the movable or folding parts of the planter.

2.3 LOADING AND UNLOADING INSTRUCTIONS



THESE OPERATIONS SHOULD BE PERFORMED ONLY BY QUALIFIED AND EXPERIENCED PERSONNEL.



WHEN THE PLANTER IS DELIVERED, IT SHOULD BE IMMEDIATELY CHECKED TO DETECT POSSIBLE DAMAGES DURING TRANSPORTATION OR MISSING PIECES. ONLY THE IMMEDIATE REPORTING OF THIS TO THE DELIVERER WILL RESULT IN COMPENSATION.



LOADING AND UNLOADING THE MACHINE MUST BE PERFORMED, IF POSSIBLE, USING A BRIDGE CRANE.

The following pictures show the position of the holes on the FRAME (see section 3.7 FRAMES) where the tow ropes must be tied, depending on the version of the machine:

- In Version **FIXED, VARIANT MANUAL, TELESCOPIC, VARIANT and VARIANT IDRA**, the operations of **LOADING** and **UNLOADING** must be performed using 2 points (Fig. 2.1).
- In **FOLDING** versions of the machine (Fig. 2.2), the operations of **LOADING** and **UNLOADING** must be performed using 4 points:
 - 2 **MAIN** coupling points, placed on the three-point FRAME (B, Fig. 2.2).
 - 2 **SECONDARY** coupling points, placed on the supporting legs (C, Fig. 2.2).

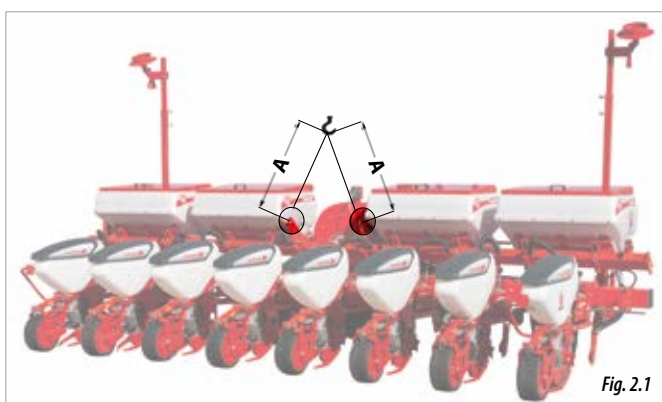

WARNING: PLEASE RESPECT THE DISTANCES **A** (2 METRES) IN ORDER TO PREVENT DAMAGES TO THE MACHINE DURING THE RAISING OPERATION (Fig. 2.1).

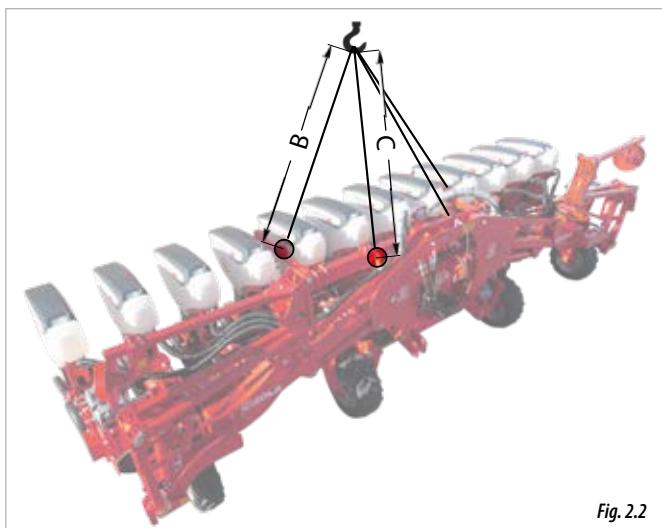

WARNING: PLEASE RESPECT THE DISTANCES **B** AND **C** (2 METRES) IN ORDER TO PREVENT DAMAGES TO THE MACHINE DURING THE RAISING OPERATION (Fig. 2.2).

2.4 SAFETY ELEMENTS

In order to prevent damages during work, the planter is equipped with a fusible pin placed in the cog of the wheels that control the transmission of the metering units (Fig. 2.3).



WHEN THE FUSIBLE PIN BREAKS, THE SOWING EQUIPMENT WILL STOP WORKING.



THE FUSIBLE PIN SHOULD BE REPLACED AFTER 500 HOURS OF WORK (SEE SECTION 9.1 CHECKING FREQUENCY). IF IT IS NOT REPLACED AFTER THIS TIME, THE FUSIBLE PIN COULD BREAK WITHOUT WARNING.

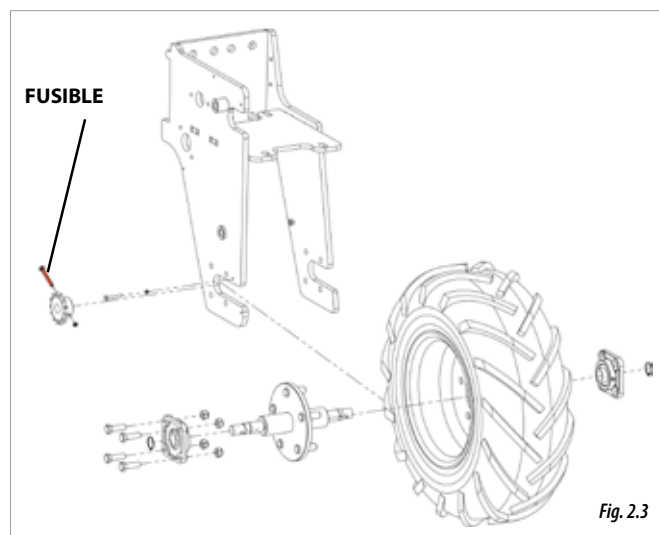

3. OVERVIEW

3.1 PLANTER OVERVIEW

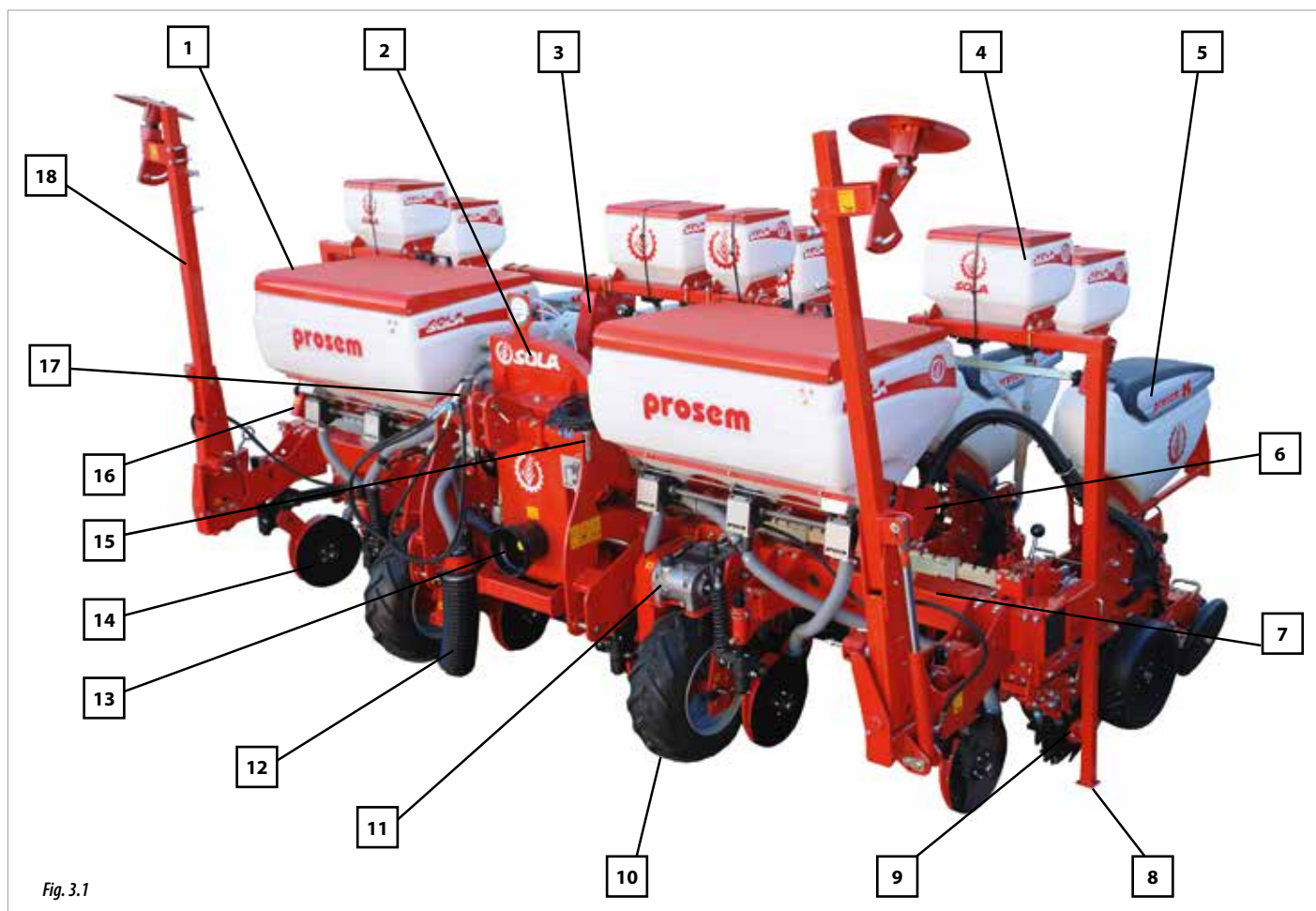
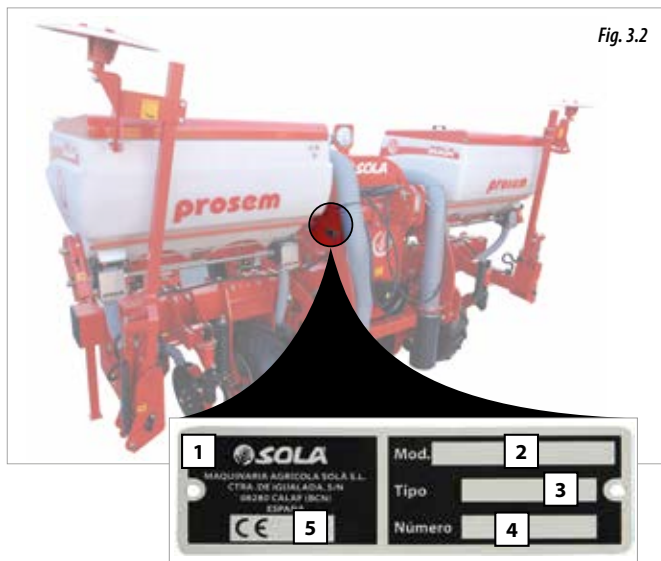

Fig. 3.1

- | | |
|--|---------------------------------------|
| 1- Fertilizer hopper. | 10- Drive wheel. |
| 2- Suction system fan. | 11- Gearbox. |
| 3- Micro Granular Fertilizer / Micro Granular Pesticide drive. | 12- Deflector. |
| 4- Micro Granular Fertilizer / Micro Granular Pesticide hopper. | 13- PTO. |
| 5- Metering Unit. | 14- Fertilizer unit. |
| 6- Air reservoir. | 15- Level indicator. |
| 7- Frame. | 16- Fertilizer hopper's drive. |
| 8- Supporting leg. | 17- Hydraulic connections. |
| 9- Furrow's residue rotary cleaner. | 18- Track marker. |

3.2 MACHINE IDENTIFICATION



Every machine has an IDENTIFICATION PLATE in the three-point linkage that specifies:

- 1- Name and address of the manufacturer.
- 2- Machine model.
- 3- Machine type.
- 4- Serial number.
- 5- CE certificate.

3.3 USE ACCORDING TO DESIGN

The precision planter PROSEM has been designed specifically for single-seed sowing of cereal and other grain seeds.

The machine has been designed to work using an agricultural tractor with lifting unity and three-point universal linkage.

This machine is able to work by using either a PTO shaft plugged into the tractor's PTO or by means of a hydraulic engine.

If the machine is used in circumstances other than those specified above, the manufacturer will not be held responsible for any damage caused to persons or to the machine.

The user must observe all regulations concerning safety, traffic and hygiene.

If the machine is modified by the user, the manufacturer's warranty is cancelled. SOLÁ will not be held responsible for any damage caused to persons or to the machine.

The use of seeds with a high moisture content should be avoided since they can cause blockages.

3.4 METERING UNIT PROSEM K

- 1- Seed hopper.
- 2- Metering box provided with a selector to adjust the seed distribution.
- 3- Planting depth controller.
- 4- Lever to adjust the pressure that the furrow closing wheels exert onto the ground.
- 5- Lever to adjust the angle which affects the bearing of the furrow closing wheels on the ground.
- 6- Furrow closing wheels : they cover the furrow where the seed has been placed.
- 7- Planting depth control wheels.
- 8- Double disc furrow opener or seed discs: it forms the furrow in which the seed will be placed.
- 9- Clod remover: prevents the clods from being in the way of the planting depth control wheels.
- 10- Blade: helps to break the superficial earth crust.
- 11- Transmission group: transfers the main axle's motion to the metering box in order to turn the seed disc.
- 12- Parallelogram: allows the metering units to move vertically to adapt to the terrain's irregularities.
- 13- Lever to adjust the unit's pressure: it adjusts the load pressure exerted by the double-disc opener (8) onto the ground.
- 14- Coupling mechanism: it allows to couple the unit in raised position in order to exclude it.
- 15- Metering unit's pressure tensioning spring: it adjusts the load pressure exerted by the double-disc opener (8) onto the ground.

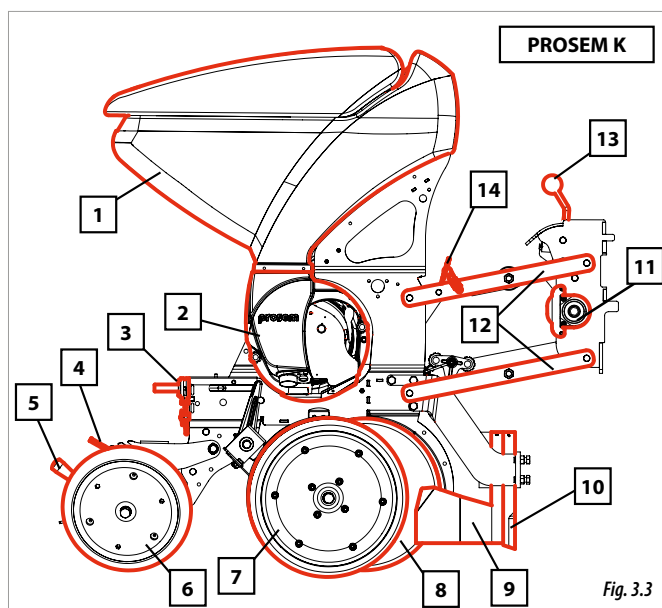

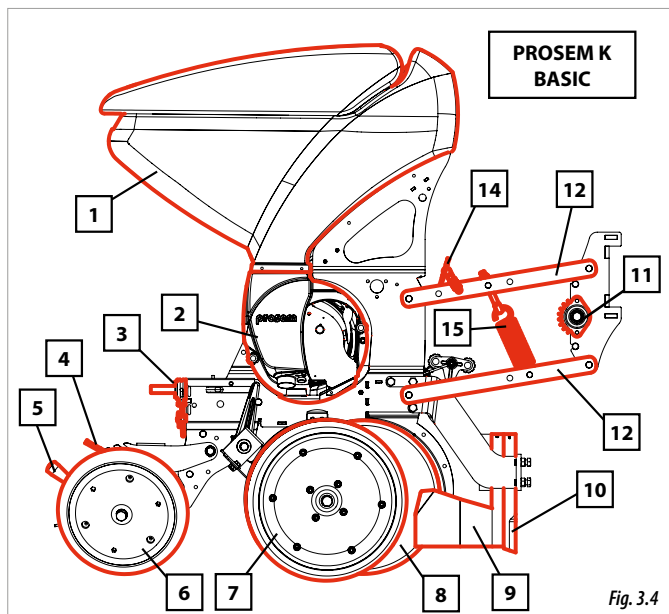

Fig. 3.4

- 14- Lever to adjust the angle which affects the bearing of the furrow closing wheels on the ground.
- 15- Furrow closing wheels : they cover the furrow where the seed has been placed.
- 16- Planting depth control front wheel.

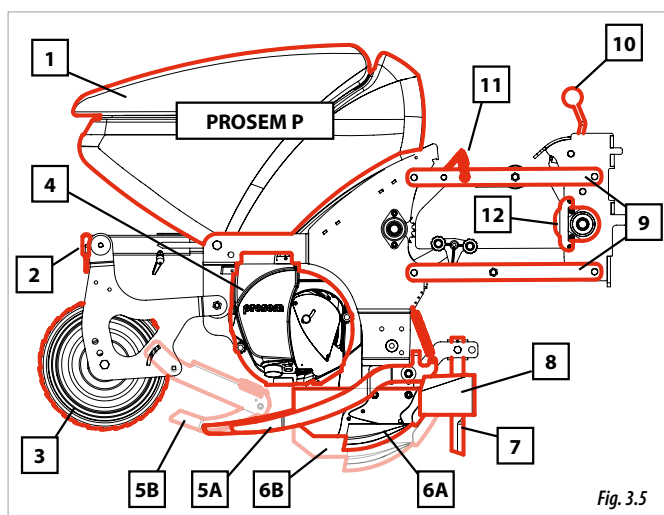

Fig. 3.5

3.5 METERING UNITS PROSEM P

- 1- Seed hopper.
- 2- Planting depth controller.
- 3- Press wheel: compresses the earth on the furrow and controls the planting depth.
- 4- Metering box: provided with a seed selector in order to perform single-seed sowing.
- 5A- Seed-covering device: it closes the furrow for the share (6A).
- 5B- Seed-covering device: it closes the furrow for the high share (6B).
- 6A- Share: it forms the furrow in which the seed will be placed. For standard planting depth.
- 6B- High share: they form the furrow in which the seed will be placed. For very deep planting.
- 7- Shoe: helps to break the superficial earth crust.
- 8- Clod remover: it removes the clods from the way of the depth control wheels.
- 9- Parallelogram: allows the metering units to move vertically to adapt to the terrain's irregularities.
- 10- Lever to adjust the unit's pressure: it adjusts the load pressure exerted by the share (6A and 6B) onto the ground.
- 11- Sowing exclusion mechanism: it allows to couple the unit in raised position in order to exclude a metering unit.
- 12- Transmission group: transfers the main axle's motion to the metering box in order to turn the seed disc.
- 13- Metering unit's pressure tensioning spring: it adjusts the load pressure exerted by the shares (6A and 6B) onto the ground.

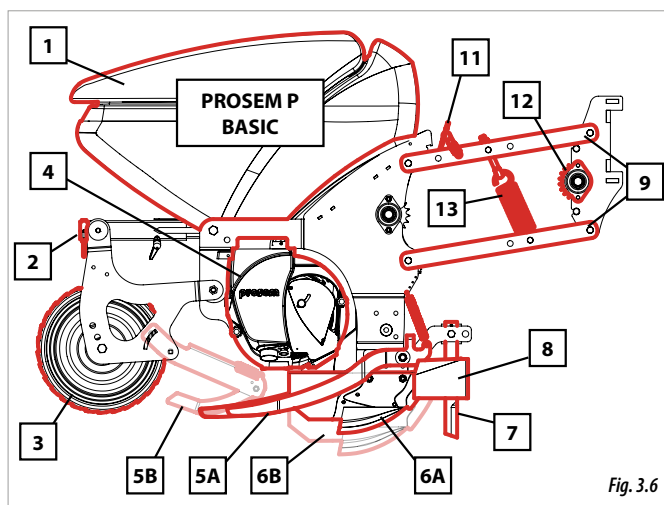

Fig. 3.6

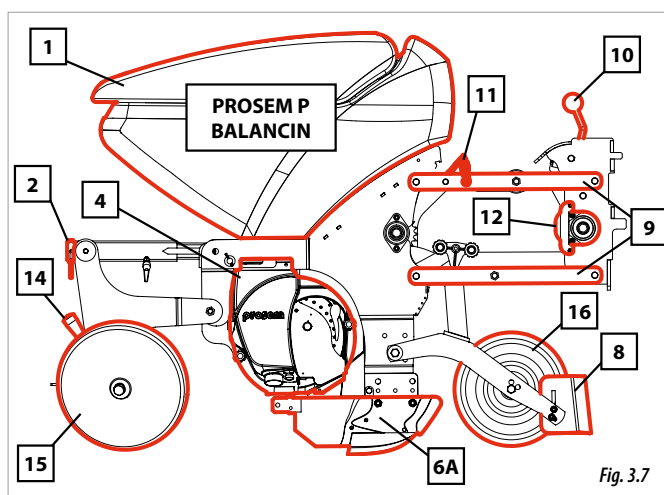

Fig. 3.7

3.6 METERING BOX

Single-seed dosing system in the metering units has been designed to select the seeds individually, so that they are placed in the furrow keeping a distance between seeds set previously by the user (see section 6.1 PLANTING DISTANCE BETWEEN SEEDS).

Main parts of the metering box:

1. Seed selector: selects a single seed for each seed disc's hole.
2. Seed disc: distributes the seeds.
3. Seed ejector: helps the seed to fall in the right direction.
4. Counter-selector slide: prevents the selector from breaking its tip because of a seed.
5. Central slides.
6. Seed falling slide: it turns off the suction when the seed needs to be detached from the seed disc.

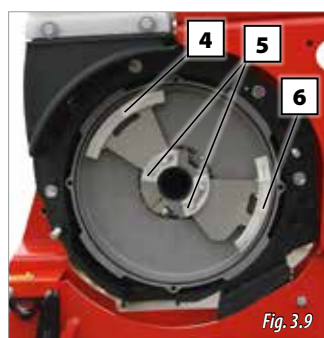
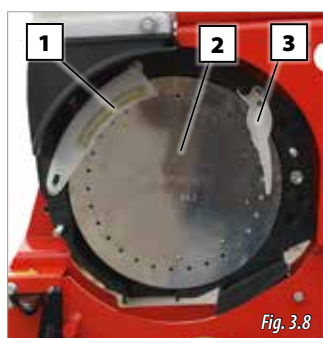

7. Seed entering gate to the metering box: adjusts the entrance of the seed into the metering box.
8. Brushes: they clean seed residue from the seed disc.
9. Inspection gate: it allows you to see inside the metering box when the machine is running to perform the required adjustments.
10. Emptying gate: it empties the seed hopper.

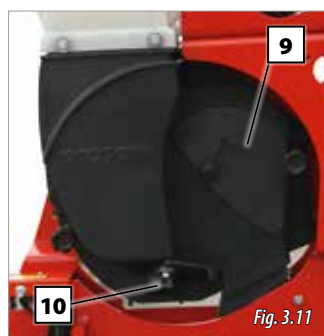
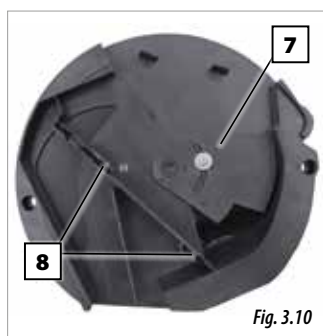

11. Seed selector adjuster.



Each type of seed needs the appropriate seed disc (2, Fig. 3.8), since the seed's size, spacing between plants, etc, require specific discs with specific number of holes to control the distance between planted seeds. Besides, the holes need to be big enough to contain a single seed.

Type of SEED DISCS depending on the type of seed:

TYPE OF SEED	N° OF HOLES	HOLE'S DIAMETRE (mm)															
		0,8	1	1,1	1,2	1,5	2	2,5	3	3,5	4	4,25	4,5	5	5,5	6,5	
SUNFLOWER	10				•		•	•									
	20				•	•	•	•									
	30								•								
CORN	10															•	
	20										•					•	
	30										•	•				•	
	40										•					•	
SORGHUM	70						•		•								
	100							•									
COTTON	70								•	•							
	100								•	•							
RAPE	70								•								
	100								•								
	120								•								
SUGAR BEET	20								•								
	30								•							•	
	40								•								
BEANS	20																•
	70																•
FABES (ASTURIAN BEANS)	20																•
BROAD BEAN	30	•			•												•
TOMATO	30		•														
	70		•														
LEEK	40										•						
	40																
GREEN BEANS	40															•	
	40																•
CHICK PEAS	50															•	
	60															•	
	60															•	
	70															•	
FRIJOLAS (MEXICAN BEAN)	50								•							•	
ROUND GREEN BEANS	60	•															
CAULIFLOWER	70	•															
	60																
	70																
	90																
SOYA BEANS	70																
	90																
	100																
CARROTS	70	•															

• Standard seed disc • Optional seed disc



IF THE CASE OF USING NON-MANUAL SPECIFIED SEEDS IN THE SEED DISCS, TAKE INTO ACCOUNT THAT WHEN THE HOLE IS BIGGER THAN EACH SEED, THESE SEEDS MAY BE ABSORBED BY THE SUCTION SYSTEM AND THEREFORE WILL NOT REACH THE FURROW BED.



BEFORE STARTING TO SOW, CHECK THAT THE TYPE OF SEED DISCS ASSEMBLED IN THE METERING BOXES MATCHES THE TYPE OF SEED TO BE USED.

3.7 FRAMES

The frame has three universal coupling points for tractors. This part of the machine is where all the metering units are assembled to. Some types of frame allow to adjust the row spacing.

There are different frame models:

- FIXED
- VARIANT MANUAL FIXED
- TELESCOPIC
- VARIANT
- VARIANT IDRA
- FOLDING



ALL MACHINES CAN RUN ON PUBLIC ROADS, YET ARE PROHIBITED IF THEY ARE EQUIPPED WITH FIXED FRAME OR VARIANT MANUAL FIXED FRAME WHOSE WIDTH IS NOT ALLOWED ACCORDING TO EACH COUNTRY'S LEGISLATION. IN THESE CASES, RUNNING ON PUBLIC ROADS WILL ONLY BE LEGAL IF THE MACHINE HAS THE OPTIONAL LONGITUDINAL TRANSPORT TROLLEY (3.13). IN THIS CASE, TRANSPORT WIDTH WILL BE 3 METRES.



Fig. 3.13



THE PLANTER CAN WORK AS A TRAILED MACHINE IF IT IS EQUIPPED WITH THE FRONT WORK TROLLEY AS OPTIONAL EQUIPMENT (3.14). TRANSPORT OF THE PLANTER ON PUBLIC ROADS USING THIS TROLLEY WILL BE LIMITED BY THE PLANTER'S WORKING WIDTH AND TRAFFIC REGULATIONS.



See section 4. TECHNICAL CHARACTERISTICS in order to know if the machine supports optional equipment.



Fig. 3.14

3.7.1 FIXED

The metering units are attached to the frame using brackets.

Spacing between rows has not a quick adjustment since the units are fixed to the frame. To modify the spacing between units, see section 6.5.1 FIXED MACHINE (Fig. 3.15)



Fig. 3.15

3.7.2 VARIANT MANUAL FIXED

This frame allows to modify the spacing between metering units. To adjust the distance between rows see section 6.5.2 VARIANT MANUAL FIXED MACHINE. (Fig. 3.16).



Fig. 3.16

3.7.3 TELESCOPIC

This model allows you to modify the spacing between the units which are at the ends of the frame. Central units are fixed by brackets. Possible adjustments can be found in section 6.5.3 TELESCOPIC MACHINE. There are two versions of this model:

- Simple telescopic (Fig. 3.17)
- Double telescopic (Fig. 3.18)
- Simple telescopic hybrid (Fig. 3.19)



Fig. 3.17



Fig. 3.18



Fig. 3.19

3.7.4 VARIANT

This frame allows to modify the spacing between every metering unit. Possible adjustments can be found in section 6.5.4 VARIANT MACHINE.

There are two versions of this model:

- Variant simple telescopic (Fig. 3.20)
- Variant double telescopic (Fig. 3.21)



Fig. 3.20



Fig. 3.21

3.7.5 VARIANT IDRA

Frame VARIANT IDRA allows to modify the spacing between every unit. The frame's working width is variable. To adjust spacing between the metering boxes, see section 6.5.5 VARIANT IDRA MACHINE (Fig. 3.22).



Fig. 3.22

3.7.6 FOLDING FRAME

This type of frame has a **CENTRAL BODY** (1, Fig. 3.23) and two **FOLDING PARTS** (2, Fig. 3.23).

The CENTRAL BODY can be:

- FIXED
- VARIANT MANUAL
- TELESCOPIC
- VARIANT IDRA

FOLDING PARTS can be:
 - FIXED
 - VARIANT MANUAL

On the GEA folding machines, the central body (1, Fig. 3.24) and the folding parts (2, Fig. 3.24) can only be FIXED frame.
 To adjust the row spacing, see section 6.5.6 FOLDING MACHINE.

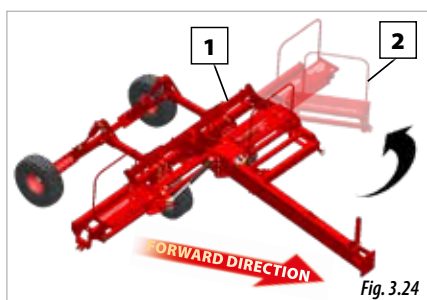

3.8 ELECTRICAL DIAGRAMS

WIRED UP EXCLUSION ROW WITH GPS

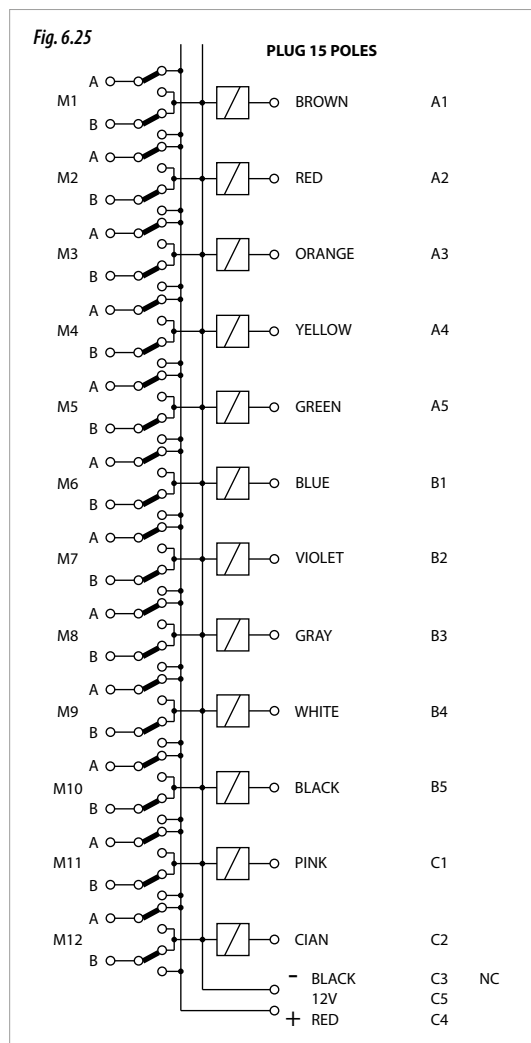

4. TECHNICAL CHARACTERISTICS

PROSEM K FIXED													
MODEL	F255/4	F255/6	F300/4	F300/5	F300/6	F350/6	F410/6	F450/6	F450/7	F600/8	F600/12	F900/12	F900/18
TOTAL WIDTH (cm)	255	255	300	300	300	350	410	450	450	600	600	900	900
MAX. ROW SPACING (CM)	33-75	33-45	33-90	33-67,5	33-55	33-65	33-75	33-80	33-70	33-80	33-50	50-75	50
SEED HOPPER CAPACITY 1 ROW (L)	50	50	50	50	50	50	50	50	50	50	50	50	50
FAN	Mechanical fan TDF 540 – Optional mechanical fan TDF 1000- Optional hydraulic fan												
TYRES	2R 23x8,5-12	2R 23x8,5-12	2R 23x8,5-12	2R 23x8,5-12	2R 23x8,5-12	2R 23x8,5-12	2R 23x8,5-12	2R 23x8,5-12	2R 23x8,5-12	2R 23x10,5-12	4R 23x8,5-12	4R 23x10,5-12	2R 23x8,5-12
CHAIN GEARBOX	●	●	●	●	●	●	●	●	●	○	○	○	○
16 GEARS AUTOMATIC GEARBOX	○	○	○	○	○	○	○	○	○	●	●	●	●
SHORT TRACK MARKERS	○	○	○	○	○	○	○	○	○	○	○	○	○
STANDARD TRACK MARKERS	-	-	-	-	-	-	-	-	-	○	○	-	-
TRACK MARKERS OF 2 SECTORS	-	-	-	-	-	-	-	-	-	○	○	○	○
TRACK MARKERS OF 3 SECTORS	-	-	-	-	-	-	-	-	-	-	-	-	-
STANDARD FERTILISER	2x210l	2x210l	2x300l	-	2x300l	2x300l	2x300l	2x300l	-	4x300l	4x300l	6x300l	**
HIGH CAPACITY FERTILISER	1x800l	1x800l	1x1080l	-	1x1080l	1x1080l	1x1080l 2x700l	1x1080l 2x700l	-	2x700l	2x700l	-	**
MICRO GRANULAR FERTILIZER (14L/ROW)	○	○	○	○	○	○	○	○	○	○	○	○	○
MICRO GRANULAR PESTICIDE (14L/ROW)	○	○	○	○	○	○	○	○	○	○	○	○	○
CENTRALISED MICRO GRANULATOR and/or INSECTICIDE	○	○	○	○	○	○	○	○	○	○	○	○	○
TURBO DISC OPENERS	○	○	○	○	○	○	○	○	○	○	○	○	○
TURBO DISC OPENERS+ FERTILISER'S DISC	○	-	○	-	-	-	○	○	-	○	○	○	○
AUTOMATIC ROW EXCLUSION	○	○	○	○	○	○	○	○	○	○	○	○	○
SOWING ELECTRONIC CONTROLLER	○	○	○	○	○	○	○	○	○	○	○	○	○
LONG. TRANSPORT TROLLEY	-	-	-	-	-	-	*	*	-	○	○	○	○
FRONT WORK TROLLEY	-	-	○	○	○	○	○	○	○	○	○	○	○
COUPLING CATEGORY	II	II	II	II	II	II	II	II	II	II	II	III	III
STANDARD MACHINE WEIGHT (KG)	940	1185	982	1105	1215	1240	1265	1300	1422	1600	2100	2250	2710
WEIGHT OF THE MACHINE WITH LONG. TRANSP. TROLLEY ⁽²⁾	-	-	-	-	-	-	*	*	-	2500	2990	3100	3590
WEIGHT OF THE MACHINE WITH FRONT WORK TROLLEY	-	-	1552	1675	1785	1810	1835	1870	1992	2170	2670	2920	3280
MINIMUM POWER (CV) ⁽¹⁾	50	60	50	60	70	70	70	80	80	100	120	120	120

● Standard ○ Optional - Not possible * CONSULT ** front fertilizer, only option. ⁽¹⁾ Guideline minimum power regarding to the planter's weight, consult the tractor's manufacturer. ⁽²⁾ Transport width: 3 metres.

PROSEM K VARIANT MANUAL FIXED					
MODEL	VM300/4	VM300/6	VM425/6	VM510/9	VM600/8
TOTAL WIDTH (cm)	300	300	425	510	600
MAX. ROW SPACING (CM)	33-90	33-55	4F33-95 6F33-75	33-60	33-80
SEED HOPPER CAPACITY 1 ROW (L)	50	50	50	50	50
FAN	Mechanical fan TDF 540 – Optional mechanical fan TDF 1000- Optional hydraulic fan				
TYRES	2R 23x8,5-12	2R 23x8,5-12	2R 23x8,5-12	2R 23x10,5-12	2R 23x10,5-12
CHAIN GEARBOX	–	–	–	–	–
16 GEARS AUTOMATIC GEARBOX	●	●	●	●	●
SHORT TRACK MARKERS	○	○	–	–	–
STANDARD TRACK MARKERS	–	–	○	○	○
TRACK MARKERS OF 2 SECTORS	–	–	–	–	○
TRACK MARKERS OF 3 SECTORS	–	–	–	–	–
STANDARD FERTILISER SPREADER	2x300 l	2x300 l	2x300 l	4x300 l	4x300 l
HIGH CAPACITY FERTILISER SPREADER	1x1080 l	1x1080 l	1x1080 l 2x700 l	2x1080 l 2x700 l	2x700 l
MICRO GRANULAR FERTILIZER (14L/ROW)	○	○	○	○	○
MICRO GRANULAR PESTICIDE (14L/ROW)	○	○	○	○	○
CENTRALISED MICRO GRANULATOR and/or INSECTICIDE	○	○	○	○	○
TURBO DISC OPENERS	○	○	○	○	○
TURBO DISC OPENERS DISCS+ FERTILISER'S DISC	○	○	○	○	○
AUTOMATIC ROW EXCLUSION	○	○	○	○	○
SOWING ELECTRONIC CONTROLLER	○	○	○	○	○
COUPLING CATEGORY	II	II	II	II	II
STANDARD MACHINE WEIGHT (KG)	1040	1290	1320	1730	1660
MINIMUM POWER (CV) ⁽¹⁾	60	70	80	90	90

● Standard

○ Optional

– Not possible

⁽¹⁾ Guideline minimum power regarding to the planter's weight, consult the tractor's manufacturer.

PROSEM K TELESCOPIC								
MODEL	T250/6	T300/6	T300/7	T300/7-S	T330/6	T330/7	T330/8	T330/7HBR
TOTAL WIDTH of open/closed MACHINE (cm)	250-405	300-435	300-364	300-450	330-430	330-430	330	330-400
MAX. ROW SPACING (cm)	70-75	70-80	45-55	55-70	70-80	55-60	50	6F80 7F60
SEED HOPPER CAPACITY 1 ROW (L)	50	50	50	50	50	50	50	50
FAN	Mechanical fan TDF 540 – Optional mechanical fan TDF 1000- Optional hydraulic fan							
TYRES	2R 23x8,5-12	2R 23x8,5-12	2R 23x8,5-12	2R 23x8,5-12	2R 23x8,5-12	2R 23x8,5-12	2R 23x8,5-12	2R 23x8,5-12
CHAIN GEARBOX	○	○	–	–	○	–	○	–
16 GEARS AUTOMATIC GEARBOX	●	●	●	●	●	●	●	●
SHORT TRACK MARKERS	–	–	–	–	–	–	–	–
STANDARD TRACK MARKERS	○	○	○	○	○	○	○	○
TRACK MARKERS OF 2 SECTORS	–	–	–	–	–	–	–	–
TRACK MARKERS OF 3 SECTORS	–	–	–	–	–	–	–	–
STANDARD FERTILIZER SPREADER	2x210 l	2x300 l	2x300 l	–	2x300 l	2x300 l	–	2x300 l
HIGH CAPACITY FERTILIZER SPREADER	1x800 l	1x1080 l	1x1080 l	–	1x1080 l	1x1080 l	–	1x1080 l
MICRO GRANULAR FERTILIZER (14L/ROW)	○	○	○	○	○	○	○	○
MICRO GRANULAR PESTICIDE (14L/ROW)	○	○	○	○	○	○	○	○
CENTRALISED MICRO GRANULATOR and/or INSECTICIDE	○	○	○	○	○	○	○	○
TURBO DISC OPENERS	○	○	○	○	○	○	–	○
TURBO DISC OPENERS+ FERTILISER'S DISC	–	–	–	–	–	–	–	–
AUTOMATIC ROW EXCLUSION	○	○	○	○	○	○	○	○
SOWING ELECTRONIC CONTROLLER	○	○	○	○	○	○	○	○
COUPLING CATEGORY	II	II	II	II	II	II	II	II
STANDARD MACHINE WEIGHT (KG)	1400	1480	1590	1610	1500	1610	1720	1615
MINIMUM POWER (CV)⁽¹⁾	80	90	90	90	90	90	90	90

● Standard ○ Optional – Not possible

⁽¹⁾ Guideline minimum power regarding to the planter's weight, consult the tractor's manufacturer.

PROSEM K VARIANT						
MODEL	V300/6 45-75	V300/6 50-80	V300/6 4F95 6F70-80	V300/6 4F95 6F50-75	V300/7 6F75-80 7F45-60	V300/7-S
TOTAL WIDTH of open/closed MACHINE (cm)	300-435	300-450	300-435	300-407	300-450	300-512
MAX. ROW SPACING (cm)	45-75	50-80	4F95 6F50-75	4F95 6F50-75	6F75-80 7F45-60	50-80
SEED HOPPER CAPACITY 1 ROW (L)	50	50	50	50	50	50
FAN	Mechanical fan TDF 540 – Optional mechanical fan TDF 1000- Optional hydraulic fan					
TYRES	2R 23x8,5-12	2R 23x8,5-12	2R 23x8,5-12	2R 23x8,5-12	2R 23x8,5-12	2R 23x8,5-12
CHAIN GEARBOX	–	–	–	–	–	–
16 GEARS AUTOMATIC GEARBOX	●	●	●	●	●	●
SHORT TRACK MARKERS	–	–	–	–	–	–
STANDARD TRACK MARKERS	○	○	○	○	○	○
TRACK MARKERS OF 2 SECTORS	–	–	–	–	–	–
TRACK MARKERS OF 3 SECTORS	–	–	–	–	–	–
STANDARD FERTILIZER SPREADER	2x300 l	2x300 l	2x300 l	2x300 l	–	–
HIGH CAPACITY FERTILIZER SPREADER	1x1080 l	1x1080 l	1x1080 l	1x1080 l	1x1080 l	1x1080 l
MICRO GRANULAR FERTILIZER (14L/ROW)	○	○	○	○	○	○
MICRO GRANULAR PESTICIDE (14L/ROW)	○	○	○	○	○	○
CENTRALISED MICRO GRANULATOR and/or INSECTICIDE	○	○	○	○	○	○
FERTILIZER'S DISC	*	*	*	*	*	*
TURBO DISC OPENERS	*	*	*	*	*	*
TURBO DISC OPENERS+ FERTILIZER'S DISC	–	–	–	–	–	–
AUTOMATIC ROW EXCLUSION	○	○	○	○	○	○
SOWING ELECTRONIC CONTROLLER	○	○	○	○	○	○
COUPLING CATEGORY	II	II	II	II	II	II
STANDARD MACHINE WEIGHT (KG)	1450	1470	1460	1480	1610	1650
MINIMUM POWER (CV) ⁽¹⁾	80	80	80	80	90	90

● Standard ○ Optional – Not possible * CONSULT

⁽¹⁾ Guideline minimum power regarding to the planter's weight, consult the tractor's manufacturer.

PROSEM K VARIANT IDRA				
MODEL	IDRA300/8	IDRA330/8	IDRA300/9	IDRA330/9
TOTAL WIDTH (cm)	300-555	330-590	300-470	330-590
MAX. ROW SPACING (cm)	40-75	45-80	8F65-75 F40-55	8F70-80 9F45-60
SEED HOPPER CAPACITY 1 ROW (L)	50	50	50	50
FAN	Mechanical fan TDF 540 – Optional mechanical fan TDF 1000- Optional hydraulic fan			
TYRES	23x10,5-12	23x10,5-13	23x10,5-14	23x10,5-16
CHAIN GEARBOX	–	–	–	–
16 GEARS AUTOMATIC GEARBOX	●	●	●	●
SHORT TRACK MARKERS	–	–	–	–
STANDARD TRACK MARKERS	○	○	○	○
TRACK MARKERS OF 2 SECTORS	○	○	○	○
TRACK MARKERS OF 3 SECTORS	–	–	–	–
STANDARD FERTILIZER SPREADER*	–	–	–	–
HIGH CAPACITY FERTILIZER SPREADER*	–	–	–	–
MICRO GRANULAR FERTILIZER (14L/ROW)	○	○	○	○
MICRO GRANULAR PESTICIDE (14L/ROW)	○	○	○	○
CENTRALISED MICRO GRANULATOR and/or INSECTICIDE	○	○	○	○
TURBO DISC OPENERS	–	–	–	–
TURBO DISC OPENERS+FERTILISER'S DISC	–	–	–	–
AUTOMATIC ROW EXCLUSION	○	○	○	○
SOWING ELECTRONIC CONTROLLER	○	○	○	○
COUPLING CATEGORY	II	II	II	II
STANDARD MACHINE WEIGHT (KG)	1920	1950	2040	2070
MINIMUM POWER (CV) ⁽¹⁾	120	120	120	120

● Standard ○ Optional – Not possible * Front fertilizer, only choice

⁽¹⁾ Guideline minimum power regarding to the planter's weight, consult the tractor's manufacturer.

PROSEM K FOLDING												
MODEL	FP300/8	FP300/9	FP300/12	FP400/12	VMP300/12	VMP300/12	TP300/10	TP300/11	TP340/10	TP300/11	VP300/12	VP330/12
TOTAL WIDTH (CM)	300	300	300	400	300	300	300	300	340	300	300	330
MAX. ROW SPACING (CM)	70-80	60-68-70	45-50	70-75	12F45-50 8F75-80	12F50 9F60-68 8F75-80	75-80	60	80	70	75	80
SEED HOPPER CAPACITY 1 ROW (L)	50	50	50	50	50	50	50	50	50	50	50	50
FAN	Mechanical fan TDF 540 – Optional mechanical fan TDF 1000- Optional hydraulic fan											
TYRES	23x10,5-12 23x8,5-12	23x10,5-12 23x8,5-12	23x10,5-12 23x8,5-12	23x10,5-12 23x8,5-12	23x10,5-12 23x8,5-12	23x10,5-12 23x8,5-12	26x12,00-8 23x8,5-12	26x12,00-8 23x8,5-12	26x12,00-8 23x8,5-12	26x12,00-8 23x8,5-12	26x12,00-8 23x8,5-12	26x12,00-8 23x8,5-12
CHAIN GEARBOX	-	-	-	-	-	-	-	-	-	-	-	-
16 GEARS AUTOMATIC GEARBOX	●	●	●	●	●	●	●	●	●	●	●	●
TRACK MARKERS OF 3 SECTORS (3,4 M)	○	○	○	-	○	○	-	-	-	-	-	-
TRACK MARKERS OF 3 SECTORS (4,4 M)	-	-	-	○	-	-	○	○	○	○	○	○
FERTILISER	*	*	*	*	*	*	*	*	*	*	*	*
MICRO GRANULAR FERTILIZER (14L/ROW)	○	○	○	○	○	○	○	○	○	○	○	○
MICRO GRANULAR PESTICIDE (14L/ROW)	○	○	○	○	○	○	○	○	○	○	○	○
CENTRALISED MICRO GRANULATOR and/or INSECTICIDE	○	○	○	○	○	○	○	○	○	○	○	○
TURBO DISC OPENERS	○	○	○	○	○	○	○	○	○	○	○	○
TURBO DISC OPENERS+FERTILISER'S DISC	-	-	-	-	-	-	-	-	-	-	-	-
AUTOMATIC ROW EXCLUSION	○	○	○	○	○	○	○	○	○	○	○	○
SOWING ELECTRONIC CONTROLLER	○	○	○	○	○	○	○	○	○	○	○	○
COUPLING CATEGORY	II	II	II	III	II	II	II	II	II	II	II	II
STANDARD MACHINE WEIGHT (KG)	120	2505	2850	2900	140	140	150	150	150	150	150	160
MINIMUM POWER (CV) ⁽¹⁾	120	120	140	150	140	140	150	150	150	150	150	160

● Standard ○ Optional – Not possible
 * Front fertilizer, only option. with double fertilizer disc on element support
 (1) Guideline minimum power regarding to the planter's weight, consult the tractor's manufacturer.
 (2) Transport width: 3 metres.

5. STARTING



ADJUST THE PLANTER AND ALL ITS COMPONENTS TO THE TYPE OF TERRAIN TO BE PLANTED ON (SEE SECTION 5.3 PLANTING ADJUSTMENTS).

Before working with the planter, the following points should be taken into account:

- Check that all the components of the planter are correctly lubricated. Grease periodically the mechanical elements (see section 9.2 GREASING AND LUBRICATION).
- Check the tyre pressure (see section 9.8 TYRE PRESSURE)
- In the case that the planter is equipped with an automatic transmission gearbox, check the oil level (see section 9.5 AUTOMATIC GEARBOX).
- Check that the ducts of the hydraulic system of the planter are in good condition.
- Check that the ducts of the suction system are in good condition.

After coupling the planter to the tractor:

- Check the planter is correctly coupled to the tractor.
- Before starting the planter, become familiar with all its parts and adjustments.
- Start the planter when the hopper is empty in order to free the pipes from condensation water or impurities.

5.1 COUPLING TO THE TRACTOR

The planter PROSEM is provided with couplings of category 2 and 3.



MAKE SURE THAT NO PERSON OR OBJECT IS EVER BETWEEN THE PLANTER AND THE TRACTOR WHEN COUPLING OR UNCOUPLING BOTH MACHINES.



THESE OPERATIONS REQUIRE THE UTMOST ATTENTION TO PREVENT PHYSICAL INJURIES TO THE PERSON OPERATING THE MACHINE.



THE COUPLING AND UNCOUPLING MANEUVERS REQUIRE USING THE SUPPORTING LEGS IN THEIR LOWEST POSITION.



IN MACHINES WITH LONGITUDINAL TRANSPORT TROLLEY (OPTIONAL), UNPLUG THE TROLLEY'S HYDRAULIC CONNECTIONS BEFORE COUPLING THE PLANTER IN WORK POSITION.

For the coupling maneuver, follow these steps:

1a- If the machine is provided with coupling bar (Fig. 5.1), make sure that the two levers of the three-point linkage are un-fastened and pressed downwards (Fig. 5.3). Then assemble the quick coupling bar to the rear hydraulic links of the tractor and, next, use the tractor to place the bar in the machine's holes. Finally, raise the tractor's links until you hear "click". This means that the bar is correctly placed.

1b- If the machine is not provided with coupling bar (Fig. 5.2), first place the fast-locking balls in the machine's coupling bolts and, next, couple the tractor links to these bolts.

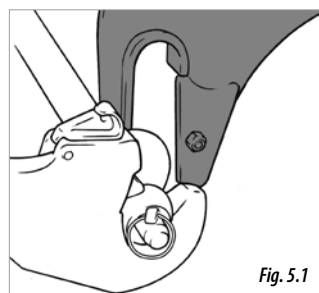

Fig. 5.1

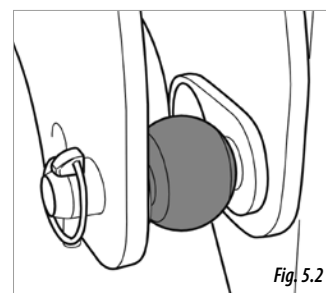

Fig. 5.2

2- Couple the tractor's tensioning arm to the third point of the three-point linkage and place the pin with safety ring (Fig. 5.4).

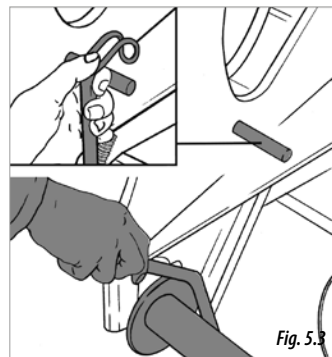

Fig. 5.3

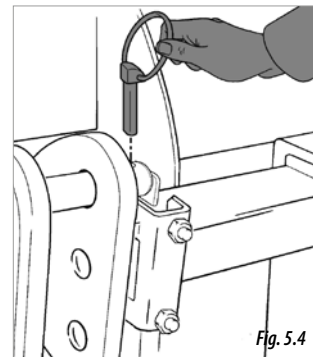

Fig. 5.4



IMPORTANT: DO NOT FORGET TO PLACE THE SAFETY RING.

3- Adjust the length of the tractor's tensioning arm until the machine is parallel to the ground. For this purpose, use the level placed on the tripod's side.

4- Connect the following plugs from the hydraulic system to the tractor's hydraulic connections (Fig. 5.5):

- TRACK MARKERS
- SUCTION FAN (in models provided with hydraulic fan).
- FRAME, in models: TELESCOPIC, VARIANT, IDRA AND FOLDING.
- FRONTAL FRAME (OPTIONAL EQUIPMENT).

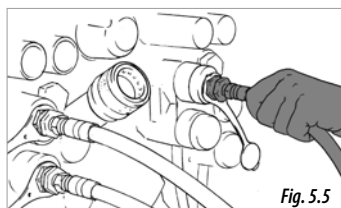

nes while keeping the safety pin pressed. Then, release the safety pin and pull the PTO shaft back until you hear “click”. That means that the pin is in place.

Look for the minimal movement length “L” (fig. 5.9) by raising and lowering the hydraulic lift.

Cut the spare plastic and metal into parts of the same length and remount the PTO shaft.

Operate the hydraulic lift and check that the PTO shaft’s movement is correct.

Secure the PTO shaft using the chain (Fig. 5.11).



IN MACHINES WITH MECHANICAL FAN, COUPLE BOTH THE TRACTOR’S PTO’S SHAFT AND THE PLANTER’S PTO SHAFT TO THE PTO SHAFT (SEE SECTION 5.2 Connecting and adapting the PTO shaft)

5- Before starting to work with the machine, raise the machine’s supporting legs (Fig. 5.7).

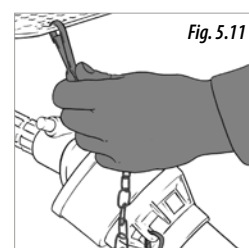
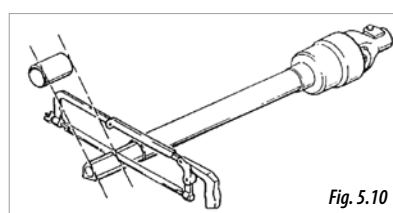
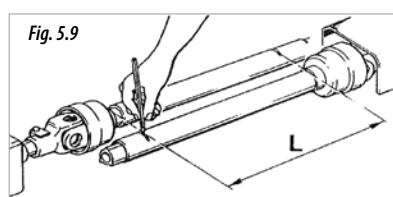
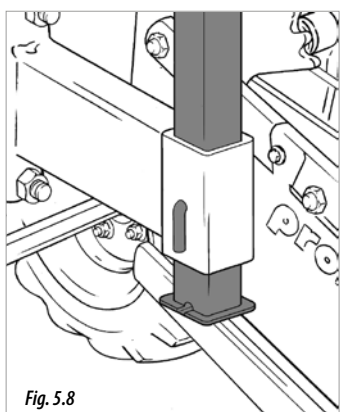
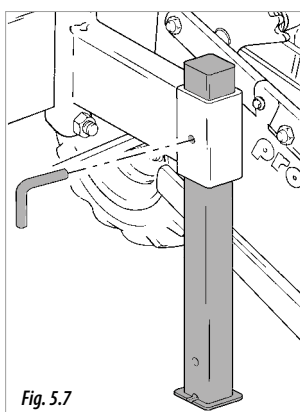

BEFORE RUNNING WITH THE MACHINE, PLEASE CHECK THAT IT IS CORRECTLY COUPLED TO THE TRACTOR.



TO UNCOUPLE THE MACHINE FROM THE TRACTOR, PERFORM THE FORMER STEPS IN THE REVERSE ORDER.



WHEN OPERATING THE PTO SHAFT CHECK THAT THE ENGINE IS OFF. ALWAYS WORK WITH THE PTO SHAFT PROTECTED AND IN GOOD CONDITION. PREVENT THE PTO SHAFT’S TUBE FROM TURNING BY SECURING IT WITH THE CHAIN PROVIDED.



WHEN LOWERING THE PLANTER TO THE GROUND, UNPLUG THE TRACTOR’S UNIVERSAL JOINT SHAFT SO THAT THE PTO SHAFT DOES NOT HAVE AN EXCESSIVE INCLINATION (MAX. 35°).



WHEN HOLDING THE TRACTOR UNIVERSAL JOINT SHAFT’S CLUTCH IN, PERFORM IT GENTLY. STARTING SUDDENLY COULD SERIOUSLY DAMAGE THE PLANTER.



IN PLANTERS PROVIDED WITH FRONTAL TRANSPORT TROLLEY AS OPTIONAL EQUIPMENT, A HOMOKINETIC PTO SHAFT HAS TO BE COUPLED TO THE TRACTOR’S PTO SHAFT.

5.2 CONNECTING AND ADAPTING THE PTO SHAFT

Once the planter is coupled with the tractor, **THE PTO SHAFT SHOULD BE ADAPTED** in the case the planter model is provided with a mechanical fan:

The PTO shaft needs to be dismantled and one of its ends needs to be inserted into the tractor’s universal joint shaft. The other end needs to be inserted into the planter. To perform this, insert the PTO shaft into the axles of both machi-

5.3 PLANTING ADJUSTMENTS

In this section you are shown the adjustments to be performed on the machine in order to make it adequate for the terrain and the type of seed:

- 1-** Exclude the metering units that are not going to be used (see section 6.7 EXCLUDING A METERING UNIT).
- 2-** Adjust the row spacing to the type of seed to be planted (see section 6.5 ROW SPACING).
- 3-** Check that the planter's wheels are not treading the sowing rows (see section 6.6 DRIVE WHEELS).
- 4-** Adjust the distance between plants (see section 6.1 PLANTING DISTANCE BETWEEN SEEDS).
 - 4.1-** If necessary, replace the seed discs of the metering boxes when planting a different type of seed. Also replace them when the spacing between plants is greater or smaller than the one allowed by the disc discs (see section 6.2 REPLACING THE SEED DISC).
- 5-** Adjust the planting depth of the metering units to the type of seed (see section 6.8 PLANTING DEPTH).
- 6-** To correctly close the furrow, adjust the seed-covering components to the terrain's characteristics (see section 6.11 CLOSING THE FURROWS).
- 7-** Adjust the opening components to the planting depth and the terrain's characteristics (see 6.12 OPENING COMPONENTS).
- 8-** Adjust the pressure that the metering units exert onto the ground (see section 6.10 PRESSURE OF THE UNIT ONTO THE GROUND).
- 9-** In machines provided with fertilizer equipment, adjust the fertilizer dose and the depth reached by the fertilizer's discs or coulters. (see section 6.17 FERTILISING EQUIPMENT).
- 10-** In machines provided with micro granular fertilizer and/or micro granular pesticide, adjust the dose to be distributed (6.18 INSECTISIDE MICROGRANULATOR, 6.19 MICRO GRANULAR PESTICIDE, OR 6.20 INSECTISIDE MICROGRANULATOR AND MICRO GRANULAR PESTICIDE).
- 11-** In machines provided with turbo disc openers and/or furrow's residue rotary cleaners, they should be adapted to the terrain (see sections 6.13 TURBO DISC OPENERS and/or 6.14 FURROW'S RESIDUE ROTARY CLEANERS).
- 12-** Adjust the track marker's length and the track disc's orientation (see section 6.16 HYDRAULIC TRACK MARKERS).
- 13-** Once the seed hoppers have been filled:
 - 13.1** Adjust the suction values of the pneumatic circuit to the type of seed to be planted (see section 6.4 SUCTION SYSTEM – FAN).
 - 13.2** Adjust the seed distribution in the seed disc (see section 6.3 SEED DISTRIBUTION IN THE SEED DISC).

6.- ADJUSTMENTS

This chapter shows the adjustments to be performed to the planter PROSEM in order to adjust it to the type of seed and terrain properties. For a correct adjustment, follow the steps indicated in section 5.3 PLANTING ADJUSTMENTS.

Values shown in this manual could be different depending on the terrain conditions, weather factors or the condition of the machine.

6.1 PLANTING DISTANCE BETWEEN SEEDS

To adjust planting distance in each row and therefore the plant population per hectare to be planted, the transmission ratio of the machine needs to be adjusted. For this purpose, the machine is provided with a gearbox.

Depending on the type of planter, the machine is equipped with one of this two gearboxes:

- 1- CHAIN GEARBOX (Fig. 6.1).
- 2- AUTOMATIC GEARBOX (Fig. 6.2).



ADJUST THE TRANSMISSION ONLY WHEN THE MACHINE IS IN RAISED POSITION. CHECK THAT THE WHEELS THAT CONTROL THE METERING BOX'S TRANSMISSION ARE IN CONTACT WITH THE GROUND.



IN FOLDING VERSIONS OF THE MACHINE (see section 3.7.5 FOLDING FRAME). USE THE SAME ADJUSTMENTS FOR THE THREE GEARBOXES. ONE IS PLACED IN THE CENTRAL FRAME AND THE REMAINING TWO ARE PLACED IN THE FOLDING PARTS.

Depending on the type of gearbox installed in the machine, use the matching table of adjustments in order to adjust it (see sections 6.1.1 CHAIN GEARBOX or 6.1.2 AUTOMATIC GEARBOX). These tables show the possible ratios to be used depending on the number of holes on the assembled seed disc (see 3.6. METERING BOX).

The total plant population (number of plants per hectare) depends on the machine's row spacing and the planting distance, see the following tables.

TABLE OF SEEDS PER HECTARE													
Row spacing (cm)	35	37,5	40	45	50	55	60	65	70	75	80	90	95
Planting distance (cm)	NUMBER OF PLANTS PER HECTARE												
2,0	1.428.600	1.333.300	1.250.000	1.111.100	1.000.000	909.100	833.300	769.200	714.300	666.700	625.000	555.600	526.300
2,3	1.242.200	1.159.400	1.087.000	966.200	869.600	790.500	724.600	668.900	621.100	579.700	543.500	483.100	457.700
2,4	1.190.500	1.111.100	1.041.700	925.900	833.300	757.600	694.400	641.000	595.200	555.600	520.800	463.000	438.600
2,6	1.098.900	1.025.600	961.500	854.700	769.200	699.300	641.000	591.700	549.500	512.800	480.800	427.400	404.900
2,7	1.058.200	987.700	925.900	823.000	740.700	673.400	617.300	569.800	529.100	493.800	463.000	411.500	389.900
2,8	1.020.400	952.400	892.900	793.700	714.300	649.400	595.200	549.500	510.200	476.200	446.400	396.800	375.900
3,0	952.400	888.900	833.300	740.700	666.700	606.100	555.600	512.800	476.200	444.400	416.700	370.400	350.900
3,2	892.900	833.300	781.300	694.400	625.000	568.200	520.800	480.800	446.400	416.700	390.600	347.200	328.900
3,3	865.800	808.100	757.600	673.400	606.100	551.000	505.100	466.200	432.900	404.000	378.800	336.700	319.000
3,4	840.300	784.300	735.300	653.600	588.200	534.800	490.200	452.500	420.200	392.200	367.600	326.800	309.600
3,5	816.300	761.900	714.300	634.900	571.400	519.500	476.200	439.600	408.200	381.000	357.100	317.500	300.800
3,6	793.700	740.700	694.400	617.300	555.600	505.100	463.000	427.400	396.800	370.400	347.200	308.600	292.400
3,7	772.200	720.700	675.700	600.600	540.500	491.400	450.500	415.800	386.100	360.400	337.800	300.300	284.500
3,8	751.900	701.800	657.900	584.800	526.300	478.500	438.600	404.900	375.900	350.900	328.900	292.400	277.000
3,9	732.600	683.800	641.000	569.800	512.800	466.200	427.400	394.500	366.300	341.900	320.500	284.900	269.900
4,0	714.300	666.700	625.000	555.600	500.000	454.500	416.700	384.600	357.100	333.300	312.500	277.800	263.200
4,1	696.900	650.400	609.800	542.000	487.800	443.500	406.500	375.200	348.400	325.200	304.900	271.000	256.700
4,2	680.300	634.900	595.200	529.100	476.200	432.900	396.800	366.300	340.100	317.500	297.600	264.600	250.600
4,3	664.500	620.200	581.400	516.800	465.100	422.800	387.600	357.800	332.200	310.100	290.700	258.400	244.800
4,5	634.900	592.600	555.600	493.800	444.400	404.000	370.400	341.900	317.500	296.300	277.800	246.900	233.900
4,6	621.100	579.700	543.500	483.100	434.800	395.300	362.300	334.400	310.600	289.900	271.700	241.500	228.800
4,7	607.900	567.400	531.900	472.800	425.500	386.800	354.600	327.300	304.000	283.700	266.000	236.400	224.000
4,8	595.200	555.600	520.800	463.000	416.700	378.800	347.200	320.500	297.600	277.800	260.400	231.500	219.300
4,9	583.100	544.200	510.200	453.500	408.200	371.100	340.100	314.000	291.500	272.100	255.100	226.800	214.800
5,0	571.400	533.300	500.000	444.400	400.000	363.600	333.300	307.700	285.700	266.700	250.000	222.200	210.500
5,1	560.200	522.900	490.200	435.700	392.200	356.500	326.800	301.700	280.100	261.400	245.100	217.900	206.400
5,2	549.500	512.800	480.800	427.400	384.600	349.700	320.500	295.900	274.700	256.400	240.400	213.700	202.400
5,3	539.100	503.100	471.700	419.300	377.400	343.100	314.500	290.300	269.500	251.600	235.800	209.600	198.600
5,4	529.100	493.800	463.000	411.500	370.400	336.700	308.600	284.900	264.600	246.900	231.500	205.800	194.900
5,5	519.500	484.800	454.500	404.000	363.600	330.600	303.000	279.700	259.700	242.400	227.300	202.000	191.400
5,6	510.200	476.200	446.400	396.800	357.100	324.700	297.600	274.700	255.100	238.100	223.200	198.400	188.000
5,7	501.300	467.800	438.600	389.900	350.900	319.000	292.400	269.900	250.600	233.900	219.300	194.900	184.700
5,8	492.600	459.800	431.000	383.100	344.800	313.500	287.400	265.300	246.300	229.900	215.500	191.600	181.500
5,9	484.300	452.000	423.700	376.600	339.000	308.200	282.500	260.800	242.100	226.000	211.900	188.300	178.400
6,0	476.200	444.400	416.700	370.400	333.300	303.000	277.800	256.400	238.100	222.200	208.300	185.200	175.400
6,1	468.400	437.200	409.800	364.300	327.900	298.100	273.200	252.200	234.200	218.600	204.900	182.100	172.600

TABLE OF SEEDS PER HECTARE													
Row spacing (cm)	35	37,5	40	45	50	55	60	65	70	75	80	90	95
Planting distance (cm)	NUMBER OF PLANTS PER HECTARE												
6,2	460.800	430.100	403.200	358.400	322.600	293.300	268.800	248.100	230.400	215.100	201.600	179.200	169.800
6,3	453.500	423.300	396.800	352.700	317.500	288.600	264.600	244.200	226.800	211.600	198.400	176.400	167.100
6,4	446.400	416.700	390.600	347.200	312.500	284.100	260.400	240.400	223.200	208.300	195.300	173.600	164.500
6,5	439.600	410.300	384.600	341.900	307.700	279.700	256.400	236.700	219.800	205.100	192.300	170.900	161.900
6,6	432.900	404.000	378.800	336.700	303.000	275.500	252.500	233.100	216.500	202.000	189.400	168.400	159.500
6,7	426.400	398.000	373.100	331.700	298.500	271.400	248.800	229.600	213.200	199.000	186.600	165.800	157.100
6,8	420.200	392.200	367.600	326.800	294.100	267.400	245.100	226.200	210.100	196.100	183.800	163.400	154.800
6,9	414.100	386.500	362.300	322.100	289.900	263.500	241.500	223.000	207.000	193.200	181.200	161.000	152.600
7,0	408.200	381.000	357.100	317.500	285.700	259.700	238.100	219.800	204.100	190.500	178.600	158.700	150.400
7,1	402.400	375.600	352.100	313.000	281.700	256.100	234.700	216.700	201.200	187.800	176.100	156.500	148.300
7,2	396.800	370.400	347.200	308.600	277.800	252.500	231.500	213.700	198.400	185.200	173.600	154.300	146.200
7,3	391.400	365.300	342.500	304.400	274.000	249.100	228.300	210.700	195.700	182.600	171.200	152.200	144.200
7,4	386.100	360.400	337.800	300.300	270.300	245.700	225.200	207.900	193.100	180.200	168.900	150.200	142.200
7,5	381.000	355.600	333.300	296.300	266.700	242.400	222.200	205.100	190.500	177.800	166.700	148.100	140.400
7,6	375.900	350.900	328.900	292.400	263.200	239.200	219.300	202.400	188.000	175.400	164.500	146.200	138.500
7,8	366.300	341.900	320.500	284.900	256.400	233.100	213.700	197.200	183.200	170.900	160.300	142.500	135.000
7,9	361.700	337.600	316.500	281.300	253.200	230.100	211.000	194.700	180.800	168.800	158.200	140.600	133.200
8,0	357.100	333.300	312.500	277.800	250.000	227.300	208.300	192.300	178.600	166.700	156.300	138.900	131.600
8,1	352.700	329.200	308.600	274.300	246.900	224.500	205.800	189.900	176.400	164.600	154.300	137.200	130.000
8,2	348.400	325.200	304.900	271.000	243.900	221.700	203.300	187.600	174.200	162.600	152.400	135.500	128.400
8,3	344.200	321.300	301.200	267.700	241.000	219.100	200.800	185.400	172.100	160.600	150.600	133.900	126.800
8,5	336.100	313.700	294.100	261.400	235.300	213.900	196.100	181.000	168.100	156.900	147.100	130.700	123.800
8,6	332.200	310.100	290.700	258.400	232.600	211.400	193.800	178.900	166.100	155.000	145.300	129.200	122.400
8,7	328.400	306.500	287.400	255.400	229.900	209.000	191.600	176.800	164.200	153.300	143.700	127.700	121.000
8,9	321.000	299.600	280.900	249.700	224.700	204.300	187.300	172.900	160.500	149.800	140.400	124.800	118.300
9,0	317.500	296.300	277.800	246.900	222.200	202.000	185.200	170.900	158.700	148.100	138.900	123.500	117.000
9,1	314.000	293.000	274.700	244.200	219.800	199.800	183.200	169.100	157.000	146.500	137.400	122.100	115.700
9,2	310.600	289.900	271.700	241.500	217.400	197.600	181.200	167.200	155.300	144.900	135.900	120.800	114.400
9,3	307.200	286.700	268.800	238.900	215.100	195.500	179.200	165.400	153.600	143.400	134.400	119.500	113.200
9,4	304.000	283.700	266.000	236.400	212.800	193.400	177.300	163.700	152.000	141.800	133.000	118.200	112.000
9,5	300.800	280.700	263.200	233.900	210.500	191.400	175.400	161.900	150.400	140.400	131.600	117.000	110.800
9,7	294.600	274.900	257.700	229.100	206.200	187.400	171.800	158.600	147.300	137.500	128.900	114.500	108.500
9,9	288.600	269.400	252.500	224.500	202.000	183.700	168.400	155.400	144.300	134.700	126.300	112.200	106.300
10,0	285.700	266.700	250.000	222.200	200.000	181.800	166.700	153.800	142.900	133.300	125.000	111.100	105.300
10,2	280.100	261.400	245.100	217.900	196.100	178.300	163.400	150.800	140.100	130.700	122.500	108.900	103.200
10,3	277.400	258.900	242.700	215.700	194.200	176.500	161.800	149.400	138.700	129.400	121.400	107.900	102.200

TABLE OF SEEDS PER HECTARE													
Row spacing (cm)	35	37,5	40	45	50	55	60	65	70	75	80	90	95
Planting distance (cm)	NUMBER OF PLANTS PER HECTARE												
10,4	274.700	256.400	240.400	213.700	192.300	174.800	160.300	147.900	137.400	128.200	120.200	106.800	101.200
10,5	272.100	254.000	238.100	211.600	190.500	173.200	158.700	146.500	136.100	127.000	119.000	105.800	100.300
10,6	269.500	251.600	235.800	209.600	188.700	171.500	157.200	145.100	134.800	125.800	117.900	104.800	99.300
10,7	267.000	249.200	233.600	207.700	186.900	169.900	155.800	143.800	133.500	124.600	116.800	103.800	98.400
10,8	264.600	246.900	231.500	205.800	185.200	168.400	154.300	142.500	132.300	123.500	115.700	102.900	97.500
10,9	262.100	244.600	229.400	203.900	183.500	166.800	152.900	141.100	131.100	122.300	114.700	101.900	96.600
11,0	259.700	242.400	227.300	202.000	181.800	165.300	151.500	139.900	129.900	121.200	113.600	101.000	95.700
11,1	257.400	240.200	225.200	200.200	180.200	163.800	150.200	138.600	128.700	120.100	112.600	100.100	94.800
11,4	250.600	233.900	219.300	194.900	175.400	159.500	146.200	135.000	125.300	117.000	109.600	97.500	92.300
11,6	246.300	229.900	215.500	191.600	172.400	156.700	143.700	132.600	123.200	114.900	107.800	95.800	90.700
11,7	244.200	227.900	213.700	189.900	170.900	155.400	142.500	131.500	122.100	114.000	106.800	95.000	90.000
11,8	242.100	226.000	211.900	188.300	169.500	154.100	141.200	130.400	121.100	113.000	105.900	94.200	89.200
12,0	238.100	222.200	208.300	185.200	166.700	151.500	138.900	128.200	119.000	111.100	104.200	92.600	87.700
12,1	236.100	220.400	206.600	183.700	165.300	150.300	137.700	127.100	118.100	110.200	103.300	91.800	87.000
12,2	234.200	218.600	204.900	182.100	163.900	149.000	136.600	126.100	117.100	109.300	102.500	91.100	86.300
12,4	230.400	215.100	201.600	179.200	161.300	146.600	134.400	124.100	115.200	107.500	100.800	89.600	84.900
12,5	228.600	213.300	200.000	177.800	160.000	145.500	133.300	123.100	114.300	106.700	100.000	88.900	84.200
12,7	225.000	210.000	196.900	175.000	157.500	143.200	131.200	121.100	112.500	105.000	98.400	87.500	82.900
12,9	221.500	206.700	193.800	172.300	155.000	140.900	129.200	119.300	110.700	103.400	96.900	86.100	81.600
13,0	219.800	205.100	192.300	170.900	153.800	139.900	128.200	118.300	109.900	102.600	96.200	85.500	81.000
13,2	216.500	202.000	189.400	168.400	151.500	137.700	126.300	116.600	108.200	101.000	94.700	84.200	79.700
13,4	213.200	199.000	186.600	165.800	149.300	135.700	124.400	114.800	106.600	99.500	93.300	82.900	78.600
13,6	210.100	196.100	183.800	163.400	147.100	133.700	122.500	113.100	105.000	98.000	91.900	81.700	77.400
13,8	207.000	193.200	181.200	161.000	144.900	131.800	120.800	111.500	103.500	96.600	90.600	80.500	76.300
13,9	205.500	191.800	179.900	159.900	143.900	130.800	119.900	110.700	102.800	95.900	89.900	79.900	75.700
14,1	202.600	189.100	177.300	157.600	141.800	128.900	118.200	109.100	101.300	94.600	88.700	78.800	74.700
14,3	199.800	186.500	174.800	155.400	139.900	127.100	116.600	107.600	99.900	93.200	87.400	77.700	73.600
14,4	198.400	185.200	173.600	154.300	138.900	126.300	115.700	106.800	99.200	92.600	86.800	77.200	73.100
14,5	197.000	183.900	172.400	153.300	137.900	125.400	114.900	106.100	98.500	92.000	86.200	76.600	72.600
14,6	195.700	182.600	171.200	152.200	137.000	124.500	114.200	105.400	97.800	91.300	85.600	76.100	72.100
14,7	194.400	181.400	170.100	151.200	136.100	123.700	113.400	104.700	97.200	90.700	85.000	75.600	71.600
14,9	191.800	179.000	167.800	149.100	134.200	122.000	111.900	103.300	95.900	89.500	83.900	74.600	70.600
15,0	190.500	177.800	166.700	148.100	133.300	121.200	111.100	102.600	95.200	88.900	83.300	74.100	70.200
15,6	183.200	170.900	160.300	142.500	128.200	116.600	106.800	98.600	91.600	85.500	80.100	71.200	67.500
15,7	182.000	169.900	159.200	141.500	127.400	115.800	106.200	98.000	91.000	84.900	79.600	70.800	67.000
16,1	177.500	165.600	155.300	138.000	124.200	112.900	103.500	95.600	88.700	82.800	77.600	69.000	65.400

TABLE OF SEEDS PER HECTARE													
Row spacing (cm)	35	37,5	40	45	50	55	60	65	70	75	80	90	95
Planting distance (cm)	NUMBER OF PLANTS PER HECTARE												
16,2	176.400	164.600	154.300	137.200	123.500	112.200	102.900	95.000	88.200	82.300	77.200	68.600	65.000
16,3	175.300	163.600	153.400	136.300	122.700	111.500	102.200	94.400	87.600	81.800	76.700	68.200	64.600
16,5	173.200	161.600	151.500	134.700	121.200	110.200	101.000	93.200	86.600	80.800	75.800	67.300	63.800
17,1	167.100	155.900	146.200	130.000	117.000	106.300	97.500	90.000	83.500	78.000	73.100	65.000	61.600
17,4	164.200	153.300	143.700	127.700	114.900	104.500	95.800	88.400	82.100	76.600	71.800	63.900	60.500
18,0	158.700	148.100	138.900	123.500	111.100	101.000	92.600	85.500	79.400	74.100	69.400	61.700	58.500
18,1	157.900	147.300	138.100	122.800	110.500	100.500	92.100	85.000	78.900	73.700	69.100	61.400	58.200
18,2	157.000	146.500	137.400	122.100	109.900	99.900	91.600	84.500	78.500	73.300	68.700	61.100	57.800
18,3	156.100	145.700	136.600	121.400	109.300	99.400	91.100	84.100	78.100	72.900	68.300	60.700	57.500
18,6	153.600	143.400	134.400	119.500	107.500	97.800	89.600	82.700	76.800	71.700	67.200	59.700	56.600
19,0	150.400	140.400	131.600	117.000	105.300	95.700	87.700	81.000	75.200	70.200	65.800	58.500	55.400
19,3	148.000	138.200	129.500	115.100	103.600	94.200	86.400	79.700	74.000	69.100	64.800	57.600	54.500
19,4	147.300	137.500	128.900	114.500	103.100	93.700	85.900	79.300	73.600	68.700	64.400	57.300	54.300
20,0	142.900	133.300	125.000	111.100	100.000	90.900	83.300	76.900	71.400	66.700	62.500	55.600	52.600
20,4	140.100	130.700	122.500	108.900	98.000	89.100	81.700	75.400	70.000	65.400	61.300	54.500	51.600
20,8	137.400	128.200	120.200	106.800	96.200	87.400	80.100	74.000	68.700	64.100	60.100	53.400	50.600
21,1	135.400	126.400	118.500	105.300	94.800	86.200	79.000	72.900	67.700	63.200	59.200	52.700	49.900
21,4	133.500	124.600	116.800	103.800	93.500	85.000	77.900	71.900	66.800	62.300	58.400	51.900	49.200
21,7	131.700	122.900	115.200	102.400	92.200	83.800	76.800	70.900	65.800	61.400	57.600	51.200	48.500
21,9	130.500	121.800	114.200	101.500	91.300	83.000	76.100	70.200	65.200	60.900	57.100	50.700	48.100
22,3	128.100	119.600	112.100	99.700	89.700	81.500	74.700	69.000	64.100	59.800	56.100	49.800	47.200
23,1	123.700	115.400	108.200	96.200	86.600	78.700	72.200	66.600	61.800	57.700	54.100	48.100	45.600
23,5	121.600	113.500	106.400	94.600	85.100	77.400	70.900	65.500	60.800	56.700	53.200	47.300	44.800
23,6	121.100	113.000	105.900	94.200	84.700	77.000	70.600	65.200	60.500	56.500	53.000	47.100	44.600
24,0	119.000	111.100	104.200	92.600	83.300	75.800	69.400	64.100	59.500	55.600	52.100	46.300	43.900
24,3	117.600	109.700	102.900	91.400	82.300	74.800	68.600	63.300	58.800	54.900	51.400	45.700	43.300
24,4	117.100	109.300	102.500	91.100	82.000	74.500	68.300	63.100	58.500	54.600	51.200	45.500	43.100
24,7	115.700	108.000	101.200	90.000	81.000	73.600	67.500	62.300	57.800	54.000	50.600	45.000	42.600
25,7	111.200	103.800	97.300	86.500	77.800	70.700	64.900	59.900	55.600	51.900	48.600	43.200	41.000
26,1	109.500	102.200	95.800	85.100	76.600	69.700	63.900	58.900	54.700	51.100	47.900	42.600	40.300
27,1	105.400	98.400	92.300	82.000	73.800	67.100	61.500	56.800	52.700	49.200	46.100	41.000	38.800
27,5	103.900	97.000	90.900	80.800	72.700	66.100	60.600	55.900	51.900	48.500	45.500	40.400	38.300
27,9	102.400	95.600	89.600	79.600	71.700	65.200	59.700	55.100	51.200	47.800	44.800	39.800	37.700
29,0	98.500	92.000	86.200	76.600	69.000	62.700	57.500	53.100	49.300	46.000	43.100	38.300	36.300
29,1	98.200	91.600	85.900	76.400	68.700	62.500	57.300	52.900	49.100	45.800	43.000	38.200	36.200
30,0	95.200	88.900	83.300	74.100	66.700	60.600	55.600	51.300	47.600	44.400	41.700	37.000	35.100

TABLE OF SEEDS PER HECTARE													
Row spacing (cm)	35	37,5	40	45	50	55	60	65	70	75	80	90	95
Planting distance (cm)	NUMBER OF PLANTS PER HECTARE												
31,2	91.600	85.500	80.100	71.200	64.100	58.300	53.400	49.300	45.800	42.700	40.100	35.600	33.700
31,4	91.000	84.900	79.600	70.800	63.700	57.900	53.100	49.000	45.500	42.500	39.800	35.400	33.500
32,1	89.000	83.100	77.900	69.200	62.300	56.600	51.900	47.900	44.500	41.500	38.900	34.600	32.800
32,4	88.200	82.300	77.200	68.600	61.700	56.100	51.400	47.500	44.100	41.200	38.600	34.300	32.500
32,6	87.600	81.800	76.700	68.200	61.300	55.800	51.100	47.200	43.800	40.900	38.300	34.100	32.300
32,9	86.800	81.100	76.000	67.500	60.800	55.300	50.700	46.800	43.400	40.500	38.000	33.800	32.000
34,2	83.500	78.000	73.100	65.000	58.500	53.200	48.700	45.000	41.800	39.000	36.500	32.500	30.800
34,7	82.300	76.800	72.000	64.000	57.600	52.400	48.000	44.300	41.200	38.400	36.000	32.000	30.300
36,0	79.400	74.100	69.400	61.700	55.600	50.500	46.300	42.700	39.700	37.000	34.700	30.900	29.200
36,1	79.100	73.900	69.300	61.600	55.400	50.400	46.200	42.600	39.600	36.900	34.600	30.800	29.200
36,4	78.500	73.300	68.700	61.100	54.900	50.000	45.800	42.300	39.200	36.600	34.300	30.500	28.900
36,6	78.100	72.900	68.300	60.700	54.600	49.700	45.500	42.000	39.000	36.400	34.200	30.400	28.800
37,1	77.000	71.900	67.400	59.900	53.900	49.000	44.900	41.500	38.500	35.900	33.700	29.900	28.400
38,0	75.200	70.200	65.800	58.500	52.600	47.800	43.900	40.500	37.600	35.100	32.900	29.200	27.700
40,1	71.300	66.500	62.300	55.400	49.900	45.300	41.600	38.400	35.600	33.300	31.200	27.700	26.300
40,7	70.200	65.500	61.400	54.600	49.100	44.700	41.000	37.800	35.100	32.800	30.700	27.300	25.900
42,3	67.500	63.000	59.100	52.500	47.300	43.000	39.400	36.400	33.800	31.500	29.600	26.300	24.900
42,9	66.600	62.200	58.300	51.800	46.600	42.400	38.900	35.900	33.300	31.100	29.100	25.900	24.500
44,6	64.100	59.800	56.100	49.800	44.800	40.800	37.400	34.500	32.000	29.900	28.000	24.900	23.600
47,0	60.800	56.700	53.200	47.300	42.600	38.700	35.500	32.700	30.400	28.400	26.600	23.600	22.400
48,6	58.800	54.900	51.400	45.700	41.200	37.400	34.300	31.700	29.400	27.400	25.700	22.900	21.700
49,5	57.700	53.900	50.500	44.900	40.400	36.700	33.700	31.100	28.900	26.900	25.300	22.400	21.300
51,4	55.600	51.900	48.600	43.200	38.900	35.400	32.400	29.900	27.800	25.900	24.300	21.600	20.500
52,2	54.700	51.100	47.900	42.600	38.300	34.800	31.900	29.500	27.400	25.500	23.900	21.300	20.200
54,3	52.600	49.100	46.000	40.900	36.800	33.500	30.700	28.300	26.300	24.600	23.000	20.500	19.400
55,0	51.900	48.500	45.500	40.400	36.400	33.100	30.300	28.000	26.000	24.200	22.700	20.200	19.100
58,0	49.300	46.000	43.100	38.300	34.500	31.300	28.700	26.500	24.600	23.000	21.600	19.200	18.100
58,3	49.000	45.700	42.900	38.100	34.300	31.200	28.600	26.400	24.500	22.900	21.400	19.100	18.100
60,0	47.600	44.400	41.700	37.000	33.300	30.300	27.800	25.600	23.800	22.200	20.800	18.500	17.500
62,4	45.800	42.700	40.100	35.600	32.100	29.100	26.700	24.700	22.900	21.400	20.000	17.800	16.900
65,1	43.900	41.000	38.400	34.100	30.700	27.900	25.600	23.600	21.900	20.500	19.200	17.100	16.200
65,8	43.400	40.500	38.000	33.800	30.400	27.600	25.300	23.400	21.700	20.300	19.000	16.900	16.000
69,4	41.200	38.400	36.000	32.000	28.800	26.200	24.000	22.200	20.600	19.200	18.000	16.000	15.200
72,0	39.700	37.000	34.700	30.900	27.800	25.300	23.100	21.400	19.800	18.500	17.400	15.400	14.600
73,3	39.000	36.400	34.100	30.300	27.300	24.800	22.700	21.000	19.500	18.200	17.100	15.200	14.400

6.1.1 CHAIN GEARBOX

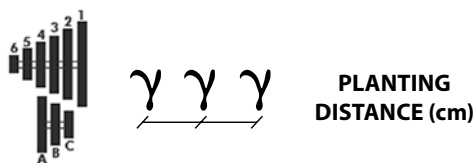

POS.	NUMBER OF HOLES ON THE SEED DISC													
	5	10	20	30	40	50	60	70	80	90	100	110	120	140
A6	47,1	23,6	11,8	7,9	5,9	4,7	3,9	3,4	2,9	2,6	2,4	2,1	2,0	1,7
A5	55,7	27,9	13,9	9,3	7,0	5,6	4,6	4,0	3,5	3,1	2,8	2,5	2,3	2,0
B6	62,9	31,4	15,7	10,5	7,9	6,3	5,2	4,5	3,9	3,5	3,1	2,9	2,6	2,2
A4	64,3	32,1	16,1	10,7	8,0	6,4	5,4	4,6	4,0	3,6	3,2	2,9	2,7	2,3
A3	72,9	36,4	18,2	12,1	9,1	7,3	6,1	5,2	4,6	4,0	3,6	3,3	3,0	2,6
B5	74,3	37,1	18,6	12,4	9,3	7,4	6,2	5,3	4,6	4,1	3,7	3,4	3,1	2,7
A2	81,4	40,7	20,4	13,6	10,2	8,1	6,8	5,8	5,1	4,5	4,1	3,7	3,4	2,9
B4	85,7	42,9	21,4	14,3	10,7	8,6	7,1	6,1	5,4	4,8	4,3	3,9	3,6	3,1
C5	89,1	44,6	22,3	14,9	11,1	8,9	7,4	6,4	5,6	5,0	4,5	4,1	3,7	3,2
B3	97,1	48,6	24,3	16,2	12,1	9,7	8,1	6,9	6,1	5,4	4,9	4,4	4,0	3,5
C4	103	51,4	25,7	17,1	12,9	10,3	8,6	7,3	6,4	5,7	5,1	4,7	4,3	3,7
B2	109	54,3	27,1	18,1	13,6	10,9	9,0	7,8	6,8	6,0	5,4	4,9	4,5	3,9
C3	117	58,3	29,1	19,4	14,6	11,7	9,7	8,3	7,3	6,5	5,8	5,3	4,9	4,2
B1	120	60,0	30,0	20,0	15,0	12,0	10,0	8,6	7,5	6,7	6,0	5,5	5,0	4,3
C2	130	65,1	32,6	21,7	16,3	13,0	10,9	9,3	8,1	7,2	6,5	5,9	5,4	4,7
C1	144	72,0	36,0	24,0	18,0	14,4	12,0	10,3	9,0	8,0	7,2	6,5	6,0	5,1



BEFORE MODIFYING THE TRANSMISSION RATIO, CHECK THAT THE PINION GEARS' POSITION IS THE CORRECT ONE FOR THE NUMBER OF HOLES ON THE DISC AND FOR THE PLANTING DISTANCE.



THE PLANTING DISTANCE VALUES ARE THEORETICAL, DEPENDING ON THE CONDITIONS OF THE TERRAIN THEY MAY VARY SLIGHTLY. CARRY OUT A FIELD TEST BEFORE STARTING TO PLANT.

To change the transmission ratio, follow these steps:

- 1- Open the lid of the transmission's box using the safety hook (Fig. 6.3).
- 2- Press the lever downwards to loosen the chain (Fig. 6.4 and Fig. 6.5).

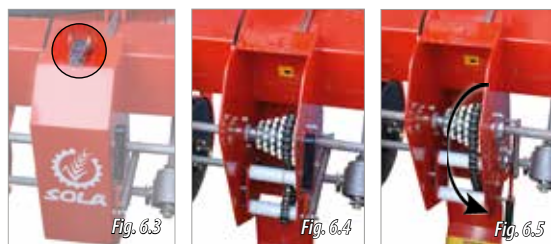

- 3- Place the chain in the correct transmission, as indicated in the table above. The group formed by 3 pinion gears corresponds to the letters A-B-C and the group formed by 6 pinion gears corresponds the numbers 1-2-3-4-5-6.
- 4- Tighten the chain by placing the lever back to its initial position (Fig. 6.7).
- 5- Finally, close the lid and secure it using the hook (Fig. 6.3).



6.1.2 AUTOMATIC GEARBOX

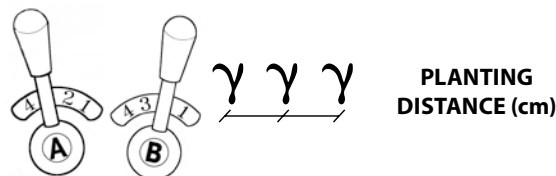

POS.	NUMBER OF HOLES ON THE SEED DISC														
	A	B	5	10	20	30	40	50	60	70	80	90	100	110	120
1	1	64,8	32,4	16,2	10,8	8,1	6,5	5,4	4,6	4,1	3,6	3,2	2,9	2,7	2,3
1	2	68,3	34,2	17,1	11,4	8,5	6,8	5,7	4,9	4,3	3,8	3,4	3,1	2,8	2,4
1	3	72,1	36,1	18,0	12,0	9,0	7,2	6,0	5,2	4,5	4,0	3,6	3,3	3,0	2,6
1	4	76,1	38,0	19,0	12,7	9,5	7,6	6,3	5,4	4,8	4,2	3,8	3,5	3,2	2,7
2	1	80,1	40,1	20,0	13,4	10,0	8,0	6,7	5,7	5,0	4,5	4,0	3,6	3,3	2,9
2	2	84,5	42,3	21,1	14,1	10,6	8,5	7,0	6,0	5,3	4,7	4,2	3,8	3,5	3,0
2	3	89,1	44,6	22,3	14,9	11,1	8,9	7,4	6,4	5,6	5,0	4,5	4,1	3,7	3,2
2	4	94,0	47,0	23,5	15,7	11,8	9,4	7,8	6,7	5,9	5,2	4,7	4,3	3,9	3,4
3	1	98,9	49,5	24,7	16,5	12,4	9,9	8,2	7,1	6,2	5,5	4,9	4,5	4,1	3,5
3	2	104,3	52,2	26,1	17,4	13,0	10,4	8,7	7,5	6,5	5,8	5,2	4,7	4,3	3,7
3	3	110,1	55,0	27,5	18,3	13,8	11,0	9,2	7,9	6,9	6,1	5,5	5,0	4,6	3,9
3	4	116,1	58,0	29,0	19,3	14,5	11,6	9,7	8,3	7,3	6,4	5,8	5,3	4,8	4,1
4	1	124,8	62,4	31,2	20,8	15,6	12,5	10,4	8,9	7,8	6,9	6,2	5,7	5,2	4,5
4	2	131,7	65,8	32,9	21,9	16,5	13,2	11,0	9,4	8,2	7,3	6,6	6,0	5,5	4,7
4	3	138,9	69,4	34,7	23,1	17,4	13,9	11,6	9,9	8,7	7,7	6,9	6,3	5,8	5,0
4	4	146,5	73,3	36,6	24,4	18,3	14,7	12,2	10,5	9,2	8,1	7,3	6,7	6,1	5,2



BEFORE MODIFYING THE TRANSMISSION RATIO, CHECK THAT THE POSITION OF THE LEVERS IN THE AUTOMATIC GEARBOX IS THE CORRECT ONE FOR THE NUMBER OF HOLES ON THE DISC AND FOR THE PLANTING DISTANCE.



THE PLANTING DISTANCE VALUES ARE THEORETICAL, DEPENDING ON THE CONDITIONS OF THE TERRAIN THEY MAY VARY SLIGHTLY. CARRY OUT A FIELD TEST BEFORE STARTING TO PLANT.

To change the transmission ratio, follow these steps:

- 1- Raise the machine to prevent that the wheels that control the metering box's transmission are in contact with the ground.
- 2- Place the lever "A" (fig. 6.8) in the correct position and turn the wheel (C, Fig. 6.8) in the forward direction until the gear clutches in. Alternatively, turn the drive wheel using your foot in the forward direction. Repeat this operation using the lever "B".

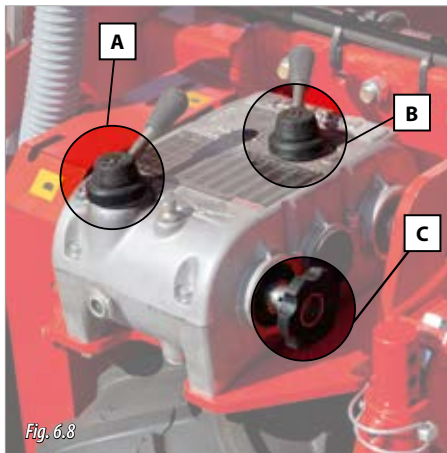

Fig. 6.8



IF, AFTER 3 OR 4 WHEEL TURNS, THE GEAR HAS NOT CLUTCHED IN, POSSIBLY THE LEVER IS MISPLACED AND THE POSITION SHOULD BE CORRECTED.

- 3- The seed disc is secured magnetically. Use both hands to pull the disc to remove it. Once it has been removed, the vacuum chamber of the metering box will be visible (Fig. 6.11).

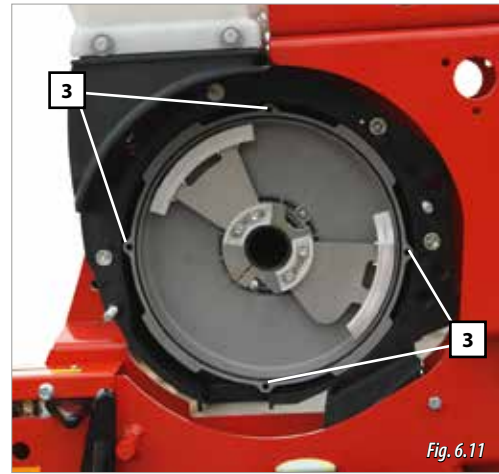

Fig. 6.11

- 4- Place the selected seed disc.



IMPORTANT: fit the tips of the seed disc's reverse into the holes of the metering box's vacuum chamber (3, Fig. 6.11).

- 5- Place both the seed selector and the seed ejector back. Use the knob to fix the seed ejector at the correct position as shown in section 6.3.2 Adjusting the seed ejector.
- 6- Place the lid back and fix it using the two knobs.

To select the correct seed disc, see the tables in sections 6.1.1 CHAIN GEARBOX or 6.1.2 AUTOMATIC GEARBOX.

6.2 REPLACING SEED DISC

- 1- Loosen the two securing knobs to remove the lid from its original place (Fig. 6.9).
- 2- Pull the seed selector (1, Fig. 6.10) to remove it from the securing groove. Then loosen the knob of the seed ejector in order to remove it (2, Fig. 6.10).

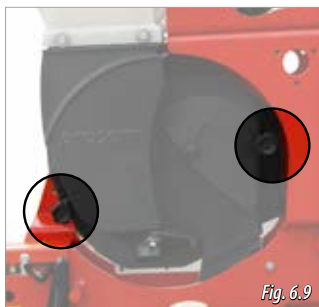

Fig. 6.9

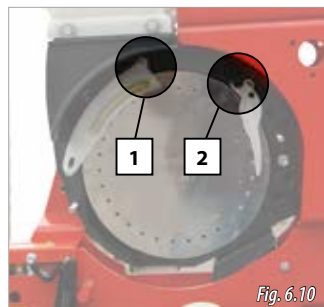

Fig. 6.10



USE ALWAYS THE SUITABLE SEED DISCS FOR EACH TYPE OF SEED (SEE SECTION 3.6 METEERING BOX).



Fig 6.12

6.3 SEED DISTRIBUTION IN THE SEED DISC

The following adjustments affect directly on the quality of the seed dosing:

1. The selector's position in relation to the disc's holes. It is important to adjust the selector's position depending on the type of seed to be distributed (see section 6.3.1. ADJUSTING THE SELECTOR).
2. The seed ejector's position in relation to the disc's holes. In order to achieve a better seed dosing, the metering box PROSEM is provided with a seed ejector slide (see 6.3.2 ADJUSTING THE SEED EJECTOR).
3. The suction power needs to be adjusted to the weight of the seeds to be planted (see section 6.4 SUCTION SYSTEM – FAN).



IN ORDER TO GET AN EVEN AND PRECISE SOWING, IT IS RECOMMENDED TO NOT SURPASS 9 KM/H IN MACHINES PROSEM K AND 6 KM/H IN MACHINES PROSEM P.



THE SELECTOR'S POSITIONS INDICATED ABOVE ARE APPROXIMATIVE; IT IS ESSENTIAL TO PERFORM TESTS AT THE BEGINNING AND DURING THE SOWING SEASON.

To check that the selector's position is the right one, follow these steps:

1. Raise the machine from the ground.
2. Use the PTO to pressurize the pneumatic system until the pressure is appropriate (see section 6.4 SUCTION SYSTEM – FAN).
3. Turn manually a driving wheel in the forward direction, loosen the inspection knob (Fig. 6.13) to check the seed distribution inside the seed disc.
4. Adjust the selector's lever position (Fig. 6.14) depending on the seed distribution inside the disc checked in the previous point. For a correct adjustment, see Fig. 6.15.



ADJUST THE SEED SELECTOR USING THE CORRECT SUCTION POWER LEVELS, AS SHOWN IN THE TABLE OF THE PREVIOUS PAGE (see section 6.4 Suction system – Fan).

6.3.1 ADJUSTING THE SELECTOR

The selector's lever can be adjusted from 0 to 10. When the lever is placed at a higher number, the selector is being moved away from the hole and, therefore, the suction power is increased. This causes a tendency towards the emergence of doubles. On the other side, when the lever is placed at a lower number, the selector is being moved closer to the hole and, therefore, the suction power is reduced. This causes a tendency towards the lack of seeds in the disc's hole.

Recommended selector's positions depending on the type of seed to be planted using **standard seed discs** (see section 3.6 Metering Box).

TYPE OF SEED	VALOR SELECTOR	
	MINIMUM	MAXIMUM
Sorghum	3,1	3,5
Sunflower	3,0	4,5
No-pilled sugar beet	2,6	3,4
Rape	2,8	3,6
Corn	3,5	4,5
Small Corn	3,0	4,0
Soya / Peas	4,0	6,0
Pilled sugar beet	3,1	4,0
Cotton	3,0	4,5
Beans	4,6	5,4
Chick peas	4,5	7,5
Broad beans*	10,0	10,0

(*) If this is not sufficient, remove the selector

5. Close the inspection gates of the metering boxes.



Fig. 6.13



Fig. 6.14

Lack of seed in the disc's holes. **INCORRECT**

Place the lever at a **HIGHER** number (for example from 2,8 to 3). If this is not enough, **increase the suction pressure.**

CORRECT position, one seed per hole

Fix the lever.

Double seeds emerge in the seed disc. **INCORRECT**

Place the lever at a **LOWER** number (for example from 2,8 to 2,6). If this is not enough, **reduce the suction pressure.**

Fig. 6.15



IMPORTANT: IN CASE THAT THE ADJUSTING VALUES ARE BIGGER OR SMALLER THAN THE ONES IN THE PREVIOUS TABLE AND THE LACK OF SEEDS IN THE DISC PERSISTS, REPLACE THE DISC BY ANOTHER ONE WITH BIGGER HOLES. IN CASE THE EMERGENCE OF DOUBLES PERSISTS, REPLACE THE DISC BY ANOTHER ONE WITH SMALLER HOLES.



THE SEED SELECTOR IS ADJUSTED USING THE LEVER PLACED OUTSIDE THE METERING BOX. FOR THIS REASON IT SHOULD NOT BE ADJUSTED MANUALLY WHEN HANDLING THE INSIDE OF THE METERING BOX. THE SEED SELECTOR SHOULD ONLY BE REMOVED TO PERFORM MAINTENANCE OR CLEANING OPERATIONS, OR TO REPLACE THE SEED DISC



THE MARK ON THE SLIDE (IN RED, FIG. 6.18) INDICATES THE ADJUSTING POINT IN STEP 4.



WHEN PLANTING PILLED SEEDS, PLACE THE SLIDE SO THAT IT COVERS $\frac{1}{4}$ OF THE HOLE, AS SHOWN IN THE PICTURE (A, FIG. 6.19).



WHEN PLANTING VERY BIG SEEDS, MOVE THE SLIDE AWAY $\frac{1}{4}$ OF THE HOLE, AS SHOWN IN THE PICTURE (B, FIG. 6.19).

6.3.2 ADJUSTING THE SEED EJECTOR



CAUTION: THE SEED EJECTOR SHOULD BE ADJUSTED BEFORE FILLING THE SEED HOPPER.

The seed ejector places every single seed in the same way on the seed disc's holes and ejects them when they reach the same place. Therefore, they are precisely placed into the furrow bed.

To adjust the seed ejector, follow these steps:

- 1- Remove the two securing knobs of the metering box's lid. (Fig. 6.16).
- 2- Remove the metering box's lid.
- 3- Loosen the slide's securing knob (Fig. 6.17).
- 4- Place the slide at the correct position. For the standard adjusting, place the slide tangent to the exterior of the disc's hole that coincide with the vacuum cut-off line. See the mark on the slide (in red, Fig. 6.18)

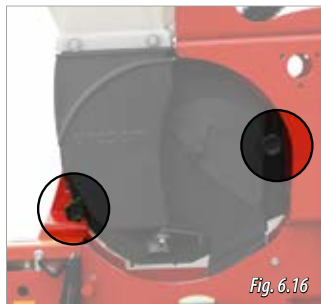

6.3.3 SEED'S INLET TO THE METERING BOX

The seed level inside the metering box is controlled using the seed entering gate place in the lid of the metering box.



IMPORTANT: THE SEED LEVEL INSIDE THE METERING BOX HAS TO BE THE CORRECT ONE FOR EACH TYPE OF SEED. IF THE LEVEL IS TOO HIGH OR TOO LOW, THE PLANTING DISTANCE IN THE SAME ROW WILL HAVE PRECISION MISTAKES.



CAUTION: THE ADJUSTMENT SHOULD BE PERFORMED BEFORE FILLING THE SEED HOPPER.

To adjust the opening of the seed entering gate, follow these steps:

1. Remove the metering box's lid by loosening the 2 securing knobs (Fig. 6.20).

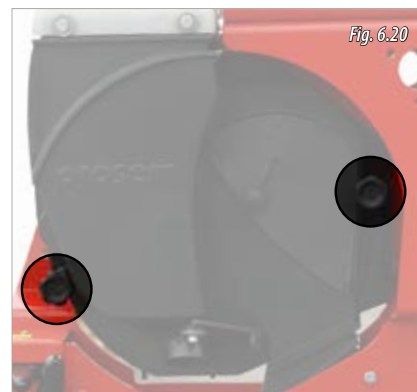
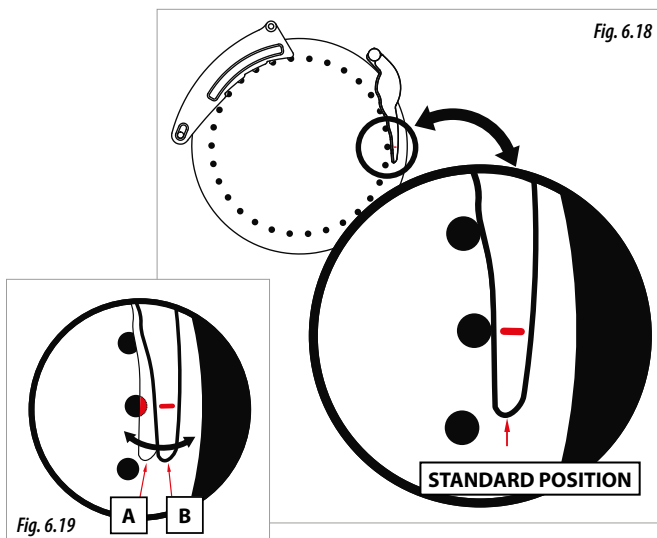

2. In the inner part of the metering box's lid, turn the gate in the appropriate direction to open or close the seed flow. Place the gate in the correct position depending on the seed type:

- A- Big seeds (Fig. 6.21), for example corn, soya, chickpeas.
- B- Regular size seeds (Fig. 6.22), for example sunflower.
- C- Small seeds (Fig. 6.23), for example sugar beet, tomato.

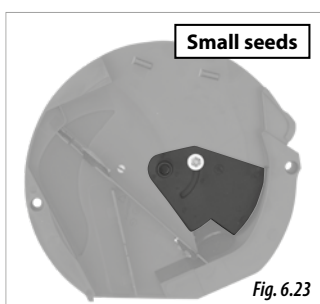
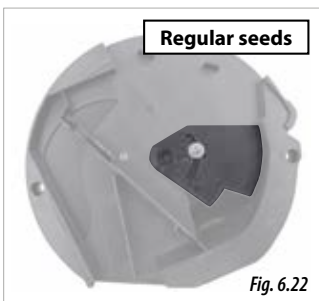
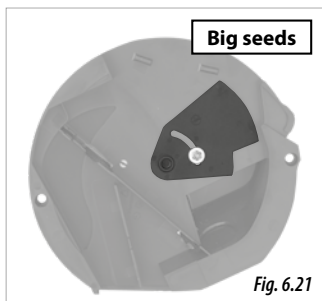

TO ADJUST CORRECTLY THE SEED LEVEL INSIDE THE METERING BOX, THERE ARE MARKS IN THE GATE CORRESPONDING TO THE SEED SIZE, ARRANGED FROM BIG TO SMALL SIZE (FIG. 6.24). TO ADJUST THE GATE, THE MARK IN THE LID (WHICH DEPENDS ON THE SEED'S SIZE) HAS TO BE ALIGNED WITH THE SCREW'S SIZE (BIG FIG. 6.21; REGULAR FIG. 6.22 OR SMALL FIG. 6.23).

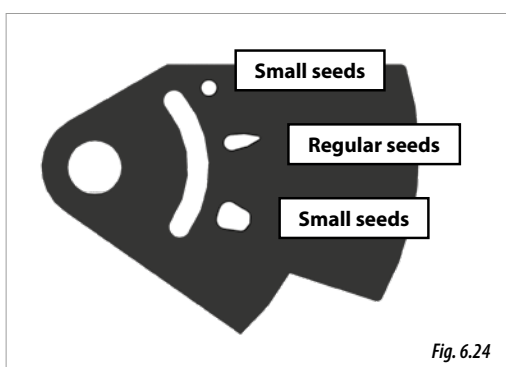

WHEN USING PILLED SEEDS, FOR EXAMPLE SUGAR BEET, THE TURNING MOVEMENT OF THE SEED DISC ABOVE THE SEED COULD BREAK IT. FOR THIS REASON, IT IS RECOMMENDED TO HAVE THE SMALLEST NUMBER OF SEEDS IN CONTACT WITH THE DISC. FOR THIS PURPOSE, ADJUST THE GATE'S POSITION FOR SMALL SEEDS (FIG. 6.23).

6.4 SUCTION SYSTEM – FAN

The suction system works by means of a fan, which can create the vacuum inside the metering boxes.

There are two different types of fan:

- **MECHANICAL FAN**
 - PTO shaft's speed: 540 rpm (standard)
 - PTO shaft's speed: 1000 rpm (optional)
- **HYDRAULIC FAN (optional).**

The fan's suction power is measured using the vacuum gauge (Fig. 6.25). Depending on the type of seed, it is recommended to adjust the suction power using the next table:



TYPE OF SEED	DEPRESSURE (cm H ₂ O / mbar)								
	20	30	40	50	60	70	80	90	100
Sunflower									
Corn									
Small Corn									
Sorghum									
Cotton									
Rape									
Sugar beet									
Beans									
Fabes (Asturian Beans)									
Broad beans									
Tomato									
Leek									
Green Beans									
Chick peas									
Frijoles-Mexican beans									
Round green beans									
Cauliflower									
Soya beans									
Carrots									

* The de-pressure values shown in the previous table correspond to standard seed discs (see section 3.6 METERING BOX).



KEEP THE AIR OUTLETS FREE OF OBSTACLES.



SUBMINISTRATE ENOUGH POWER TO THE PNEUMATIC SYSTEM UNTIL REACHING THE MINIMUM SUCTION POWER VALUES SPECIFIED IN THE TABLE. CHECK THE DEPRESSURE VALUES AFTER RUNNING THE FIRST 10 METRES.



VERY IMPORTANT: IN MODELS EQUIPPED WITH MECHANICAL FAN, THE FAN'S SUCTION POWER DEPENDS ON THE ENGINE'S RPM OF THE TRACTOR. FOR THIS REASON, KEEPING A REGULAR TURNING SPEED IS ESSENTIAL. IF IT IS NOT POSSIBLE TO LOWER ENGINE REVOLUTIONS OF THE TRACTOR, THERE IS OPTIONAL EQUIPMENT TO REGULATE MECHANICAL FAN (SEE SECTION 6.4.1 VACUUM CONTROL FOR MECHANICAL FAN).



IN MODELS EQUIPPED WITH MECHANICAL FAN, THE TIMING BELT SHOULD BE TENSIONED. IT SHOULD BE CHECKED WHEN STARTING THE SOWING SEASON, SINCE WEAR OR DAMAGE COULD CAUSE A PRESSURE LOSS IN THE SUCTION CIRCUIT (SEE SECTION 9.3 FANS).



IF THE PRESSURE LEVEL IS LOWER THAN THE ONE RECOMMENDED BY THE MANUFACTURER, THE SEED DISC'S HOLES COULD HAVE A LACK OF SEEDS. ON THE OTHER HAND, IF THE PRESSURE IS EXCESSIVE, DOUBLES COULD EMERGE OR THE DISTANCE BETWEEN SEEDS COULD BE IRREGULAR.

6.4.1 VACUUM CONTROL FOR MECHANICAL FAN (OPTIONAL)

For regulate suction mechanical fan, operate the especial screw located to Air reservoir

- 1- Loosen the nut (1, Fig. 6.25 BIS).
- 2- Turn the screw to change the fan suction (2, Fig. 6.25 BIS).
- 3- Tighten the nut to fix the screw.

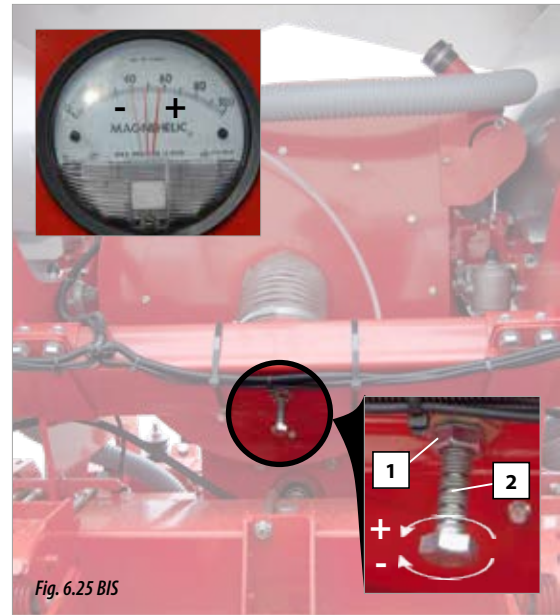

Fig. 6.25 BIS



BEFORE STARTING WORK, ADJUST VALUE AND CHECK THE FAN SUCTION.

6.4.2 PNEUMATIC TRANSPORT OF THE FERTILIZER

In models VARIANT and TELESCOPIC equipped with fertilizer unit with pneumatic transport of the exterior rows, adjust the airflow operating the adjusting valve placed in the air reservoir (A, Fig. 6.26) and the venturi place at the fan's air outlet (B, Fig. 6.26).



THE AIRFLOW NECESSARY FOR THE FERTILISER TRANSPORTATION TO THE EXTERIOR ROWS CAN DEPEND ON THE TYPE OF FERTILISER AND THE FRAME'S APERTURE CONFIGURATION.



WHEN THE ADJUSTING VALVE IS COMPLETELY OPEN (A2, FIG. 6.26) AND THE VENTURI IS AT POSITION 0 (B, FIG. 6.26), THE AIRFLOW FOR THE PNEUMATIC TRANSPORT IS MAXIMUM.



WHEN NOT SPREADING FERTILIZER, THE ADJUSTING VALVE SHOULD BE CLOSED (A1, FIG. 6.26) AND THE FAN'S VENTURI SHOULD BE AT POSITION 1 (B, FIG. 6.26).



AFTER CHANGING THE POSITION OF THE ADJUSTING VALVE, CHECK THE PRESSURE VALUES USING THE VACUUM GAUGE (FIG. 6.25). IF NECESSARY, ADJUST THE FAN'S TURNING SPEED TO ADAPT THE PRESSURE VALUES TO THE ONES IN THE TABLE OF SECTION 6.4 SUCTION SYSTEM-FAN.

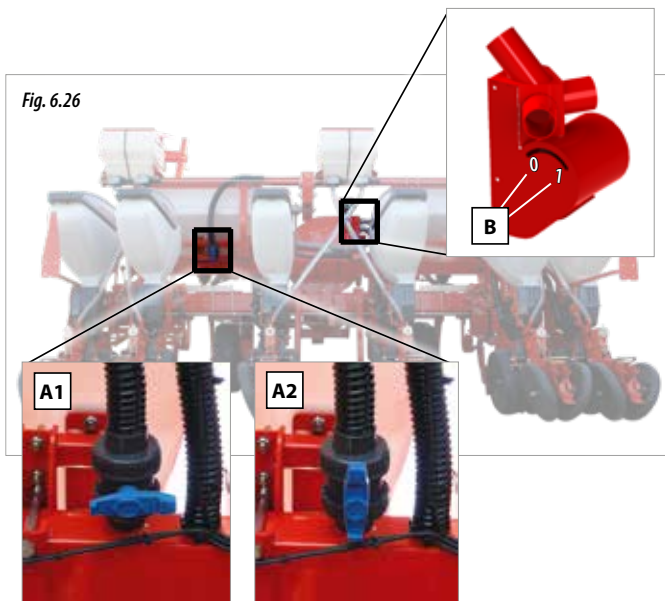

6.5.2 VARIANT MANUAL FIXED MACHINE

The machines VARIANT MANUAL FIXED allow an easy and quick adjustment to modify the distance between metering units.

The metering units are assembled along TWO SPINDLES, one for the machine's left side units and the other for those on the right side. In machines with an odd number of metering units, the central unit is fixed.



MOVE THE METERING UNITS ONLY WHEN THE MACHINE IS IN A RAISED POSITION.

Adjusting ONE METERING UNIT using the VARIANT MANUAL spindle.

1- Free the metering unit so that it can move. For this purpose, place the securing hook on the frame's base (1, Fig. 6. 28) (if the hook comes equipped)

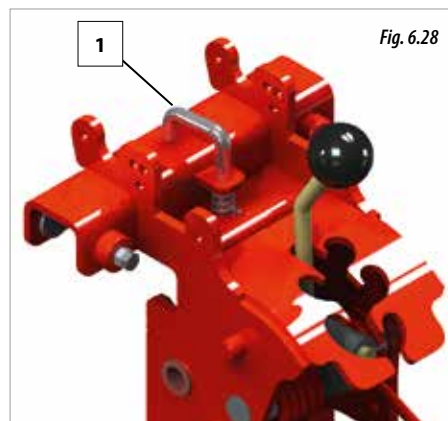

6.5 ROW SPACING

Row spacing adjustments depend on the type of seed to be sown.

To adjust the row spacing, we need to operate on the frame. The following sections show the adjustments to be performed in each frame model.

6.5.1 FIXED MACHINE

To change the distance between metering units, the unit's support needs to be disassembled and reassembled at the desired position. For this purpose, loosen the unit's securing screws, move the unit to the desired position, and re-fix it by tightening the screws.

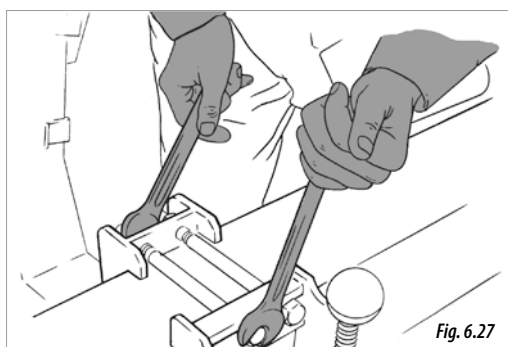

2- Place the pin (2, Fig. 6.29) only in the metering unit that is going to be moved.

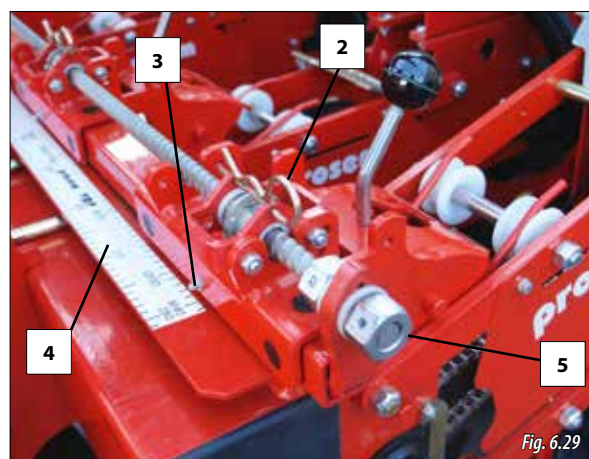

THE REMAINING METERING UNITS ASSEMBLED TO THE SAME SPINDLE NEED TO BE LOCKED (1, Fig. 6.30) AND WITHOUT PINS, UNLESS THE SPACING BETWEEN UNITS IS 40 CM OR LESS.

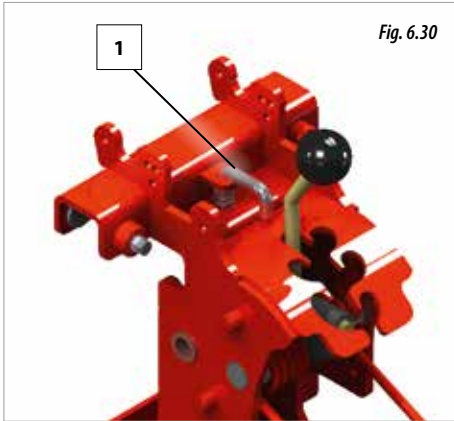

UNLOCKED UNITS (1, FIG. 6.28) WHOSE PIN IS IN PLACE (2, FIG. 6.29) WILL MOVE TOGETHER IN THE SAME DIRECTION, KEEPING THE SPACING BETWEEN ROWS. TO PREVENT A METERING UNIT FROM MOVING, REMOVE THE PIN (2, FIG. 6.29) AND USE THE SECURING HOOKS TO LOCK THE UNIT'S POSITION (1, FIG. 6.30).

- 3- Turn the spindle to modify the position of the selected metering unit. For this purpose, use a wrench to operate the nut (5, Fig. 6.29). Adjust the desired row spacing using the position indicator (3, Fig. 6.29) and the graduated scale (4, Fig. 6.29).
- 4- Block the metering unit's position using the securing hook (1, Fig. 6.30). It has to fit into one of the frame's grooves.



TELESCOPIC HYBRID MACHINES HAVE NO SECURING HOOKS. TO FIX THE POSITION OF THE METERING UNIT, REMOVE THE PIN ONCE THE ROW SPACING HAS BEEN ADJUSTED.

For a better adjustment, some machines are provided with a graduated scale (Fig. 6.31)

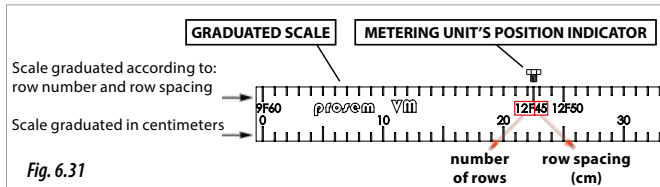

Adjusting MULTIPLE METERING UNITS using the spindle VARIANT MANUAL

- 1- First, adjust the central units (Fig. 6.32) by freeing the units which are to be moved at the same time. For this purpose, place the safety hooks onto the frame's base (1, Fig. 6.28).
- 2- Place the pins in the selected metering units which are going to be moved (2, Fig. 6.29).

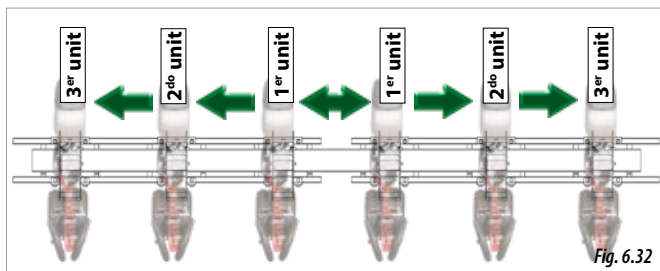

6.5.3 TELESCOPIC MACHINE

Telescopic machines allow only some distances between metering units.



ADJUST THE DISTANCE BETWEEN METERING UNITS ONLY WHEN THE MACHINE IS COMPLETELY CLOSED, OTHERWISE THE MACHINE COULD BE DAMAGED.

Telescopic machines have central metering units fixed to the frame. The lateral metering units are movable. Depending on the frame's model, the following adjustments are possible:

- 2 units, one at each frame's end, in machines with SIMPLE TELESCOPIC FRAME (Fig. 6.33).
- 4 units, two at each frame's end, in machines with DOUBLE TELESCOPIC FRAME (Fig. 6.34).

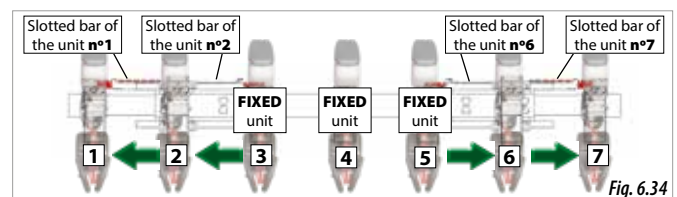
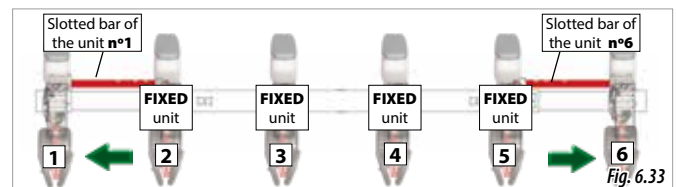

To adjust the spacing of the most exterior rows, operate the aperture stops of the slotted bars (A, Fig. 6.35) as indicated below:

- 1- Remove the pin (B, Fig. 6.35)
- 2- Next, remove the aperture stop of the bar's slot.
- 3- Place the aperture stop at the desired distance.
- 4- Place the pin in the hole to lock the stop.
- 5- Open the machine hydraulically. It will open the metering units at the desired spacing.

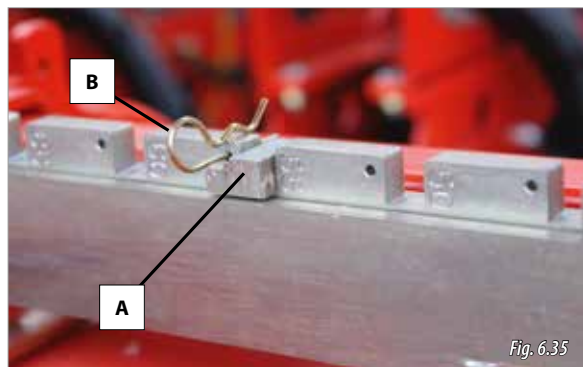

MARKS ON THE SLOTTED BARS DEFINE THE CORRESPONDING DISTANCE (cm) BETWEEN CONSECUTIVE UNITS.

6.5.4 VARIANT MACHINE

VARIANT machines allow to adjust the spacing between every unit by means of a simple and quick operation on the bars. In the next subsections, the possible adjustments will be specified depending on the VARIANT type of frame equipped in the machine.



MARKS ON THE BARS DEFINE THE CORRESPONDING DISTANCE (cm) BETWEEN CONSECUTIVE UNITS.

6.5.4.1 VARIANT V300/6 45-75 AND V300/6 50-80

This model allows to adjust the spacing of:

- **6 ROWS** at 45, 50, 55, 60, 65, 70 and 75 cm (frame **V300/6 45-75**).
- **6 ROWS** at 50, 55, 60, 65, 70, 75 and 80 cm (frame **V300/6 50-80**).



ADJUST THE DISTANCE BETWEEN METERING UNITS ONLY WHEN THE MACHINE IS COMPLETELY CLOSED, OTHERWISE THE MACHINE COULD BE DAMAGED.

6.5.3.1 TELESCOPIC HYBRID

Units No. 2,4 and 6 (as in Fig. 6.36) are fixed in the machine version TELESCOPIC HYBRID. Units No. 1,3,5 and 7 are adjustable.

Adjusting the spacing between movable units depends on the unit number:

- **Units No 1 and 7:** adjust these units using their SLOTTED BARS. To adjust the slotted bars, see section 6.5.3 TELESCOPIC MACHINE.
- **Units No 3 and 5:** adjust the spacing between units No. 2 and 3 using a spindle. Do the same to adjust the spacing between units No. 5 and 6. To adjust the spindle/ratchet see section 6.5.2 VARIANT MANUAL FIXED MACHINE – Adjusting one metering unit.

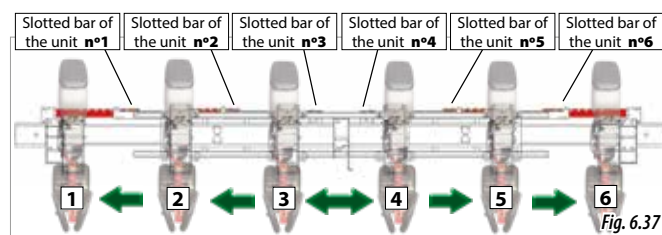
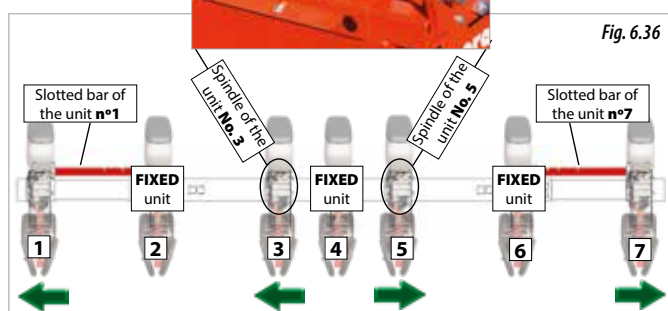

To adjust the spacing between units, operate the aperture stops of the bars (A, Fig. 6.38) as indicated below:

- 1- Remove the pin (B, Fig. 6.38)
- 2- Next, remove the aperture stop of the bar's slot (A, Fig. 6.38).
- 3- Place the aperture stop at the desired distance.
- 4- Place the pin in the hole to lock the stop.
- 5- Repeat these steps for each bar.
- 6- Open the machine using the hydraulic system: the row spacing will be the selected one.

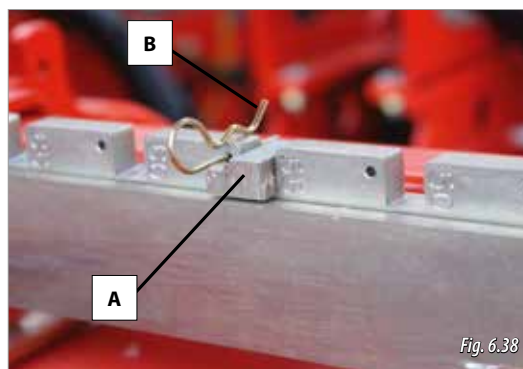

6.5.4.2 VARIANT V300/6 4F95 6F50-75

This model allows to adjust the spacing of:
 - **6 ROWS** at 50, 55, 60, 65, 70 and 75 cm
 - **4 ROWS** at 95 cm.

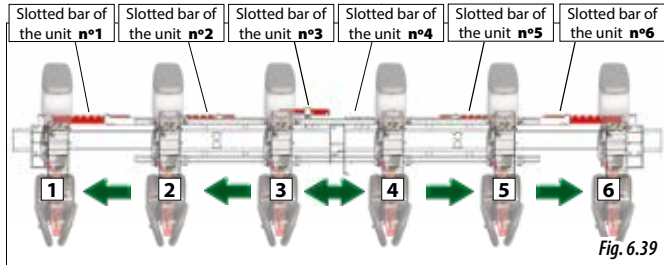

Fig. 6.39

To adjust the machine at **6 ROWS** at 50, 55, 60, 65, 70 and 75 cm, see previous section 6.5.4.1.

To adjust the machine at **4 ROWS** at 95 cm:

- 1- Exclude the units No. 2 and 5 (Fig. 6.41), see section 6.7 EXCLUDING A METERING UNIT.
- 2- Remove the pins (B, Fig. 6.40) and the aperture stops (A, Fig. 6.40).
- 3- Place the aperture stops of the units at the position of 95 cm and fix them using the pins.
- 4- Open the machine using the hydraulic system: the row spacing will be the selected one.

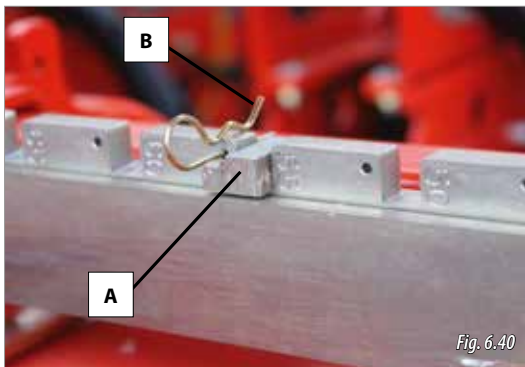

Fig. 6.40

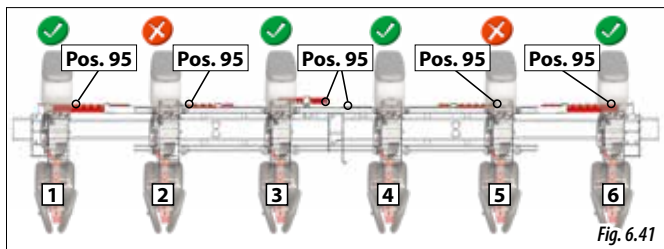

Fig. 6.41

6.5.4.3 VARIANT V300/6 4F95 6F70-80

This model allows to adjust the spacing of:
 - **6 ROWS** at 70, 75 and 80 cm
 - **4 ROWS** at 95 cm.

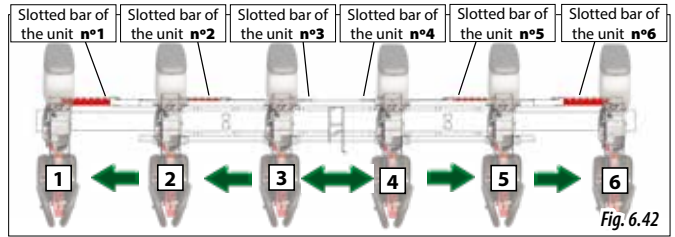

Fig. 6.42

To adjust the machine at **6 ROWS** at 70, 75 or 80, the required parts are:

- 6 APERTURE STOPS
- 4 SPECIAL 6 ROWS STOPS



Fig. 6.43



THE 6 ROW STOPS CAN BE STORED AT THE FRAME'S ENDS, IN THEIR STORAGE PLACE AT THE FRAME'S ENDS (FIG. 6.43).



IN CASE THE APERTURE STOPS ARE ASSEMBLED IN THE SLOTTED BARS, THE ADJUSTMENT SHOULD BE PERFORMED FROM STEP 7 OF THIS SECTION ON.

To adjust the 6 row spacing:

- 1- Remove the pins (B, Fig. 6.44) of the units. Also remove the aperture stops (A, Fig. 6.44).
- 2- Place the aperture stops of the following units as indicated below:
 - No. 1, 2, 5 and 6 at the 70 position.
 - No. 3 and 4 at the 4F95 position (marked on the bar).
- 3- Place the pins in the holes to lock the stops.
- 4- Open the machine using the hydraulic system.
- 5- Take the four special stops of 6 rows placed at the frame's ends and place them at position 45 for the units No. 1, 2, 5 and 6 (the machine should be open to do this).

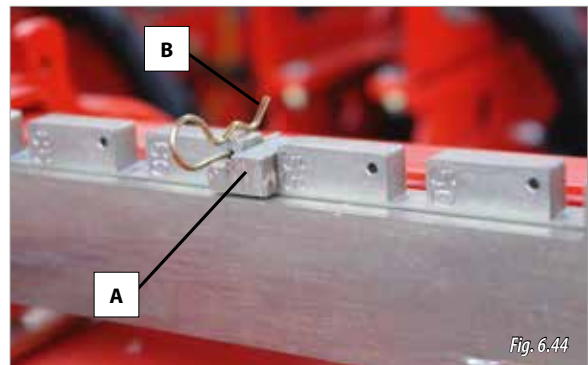

Fig. 6.44

- 6- Close the machine using the hydraulic system.
- 7- Place the aperture stops at the desired value (70, 75 or 80).
- 8- Open the machine using the hydraulic system: the row spacing will be the selected one.

To adjust the machine at **4 ROWS** at 95 cm, the following parts are required:

- 6 APERTURE STOPS



TO ADJUST THE MACHINE AT 4 ROWS, THE FOUR SPECIAL STOPS OF 6 ROWS HAVE TO BE STORED IN THEIR STORAGE PLACE AT THE FRAME'S ENDS. (FIG. 6.43).



IN CASE THE 6 ROWS SPECIAL STOPS ARE ASSEMBLED IN THE BARS AND CAN NOT BE REMOVED, OPEN SLIGHTLY THE MACHINE IN ORDER TO BE ABLE TO REMOVE THEM.

To adjust the 4 row spacing:

- 1- Exclude the units No. 2 and 5 (Fig. 6.45), see section 6.7 EXCLUDING A METERING UNIT.
- 2- Remove the metering unit's pins (B, Fig. 6.44) and the aperture stops (A, Fig. 6.44).
- 3- Place the aperture stops of the units using the pins as indicated below:
 - Units 1 and 6 at position 50.
 - Units 2 and 5 at position 45.
 - Units 3 and 4 at position 4F95 (marked on the slotted bar).
- 4- Open the machine using the hydraulic system: the row spacing will be the selected one.

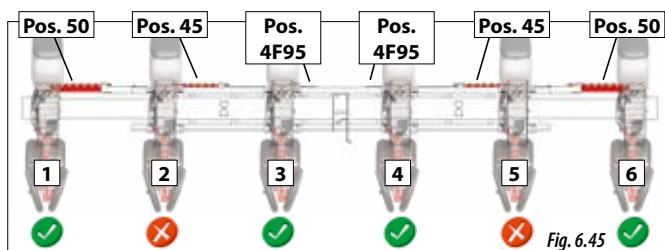

Fig. 6.45

6.5.4.4 VARIANT V300/7 7F45-60 6F70-80

This model allows to adjust the spacing of:

- **6 ROWS** at 70, 75 and 80 cm
- **7 ROWS** at 45, 50, 55 and 60 cm.

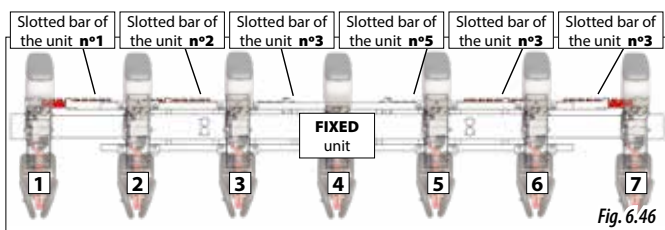

Fig. 6.46

To adjust the machine at **7 ROWS** at 45, 50, 55 and 60 cm, the required parts are:

- 6 APERTURE STOPS



TO ADJUST THE MACHINE AT 7 ROWS, THE FOUR SPECIAL STOPS OF 6 ROWS HAVE TO BE STORED IN THEIR STORAGE PLACE AT THE FRAME'S ENDS. (FIG. 6.48).



IN CASE THE 6 ROWS SPECIAL STOPS ARE ASSEMBLED IN THE BARS AND CAN NOT BE REMOVED, OPEN SLIGHTLY THE MACHINE IN ORDER TO BE ABLE TO REMOVE THEM.

To adjust the 7 row spacing:

- 1- Remove the pins (B, Fig. 6.47) of the units. Also remove the aperture stops (A, Fig. 6.47).
- 2- Place the aperture stops at the desired spacing (40, 50, 55 or 60) using the pins
- 3- Open the machine using the hydraulic system: the row spacing will be the selected one..

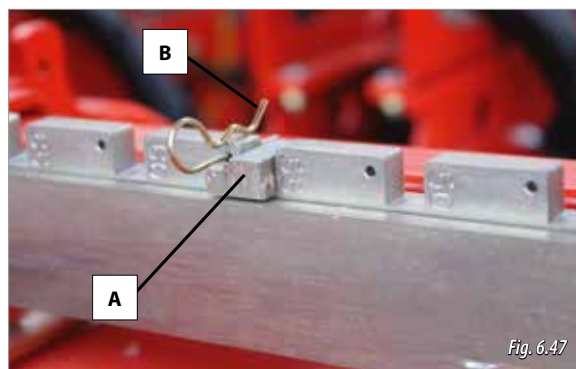

Fig. 6.47



Fig. 6.48

To adjust the machine at **6 ROWS** at 70, 75 or 80, the required parts are:

- 6 TOPES DE APERTURA
- 4 TOPES ESPECIALES DE 6 FILAS



THE 6 ROW STOPS CAN BE STORED AT THE FRAME'S ENDS, IN THEIR STORAGE PLACE AT THE FRAME'S ENDS. (FIG. 6.48)



IN CASE THE APERTURE STOPS ARE ASSEMBLED IN THE BARS, THE ADJUSTMENT SHOULD BE PERFORMED FROM STEP 7 ON.

To adjust the 6 row spacing:

- 1- Exclude the central unit (Fig. 6.49), see section 6.7 EXCLUDING A METERING UNIT.
- 2- Remove the metering unit's pins (B, Fig. 6.47) and the aperture stops (A, Fig. 6.47).
- 3- Place the aperture stops of the units at the position indicated in Fig. 6.49:

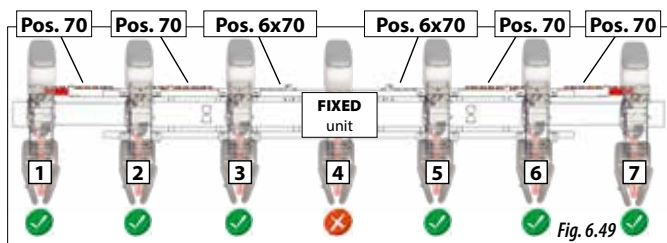

- 4- Place the pins in the holes to lock the stop.
- 5- Open the machine using the hydraulic system.
- 6- Take the four special stops of 6 rows placed at the frame's ends and place them at position 45 for the units No. 1, 2, 5 and 6 (the machine should be open to do this).
- 7- Close the machine using the hydraulic system.
- 8- Place the aperture stops of the units at the desired spacing (70, 75 or 80).
- 9- Open the machine using the hydraulic system: the row spacing will be the selected one.

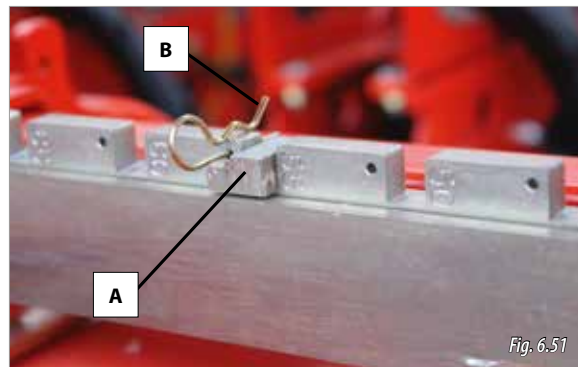

6.5.5 VARIANT IDRA MACHINE

Models VARIANT IDRA allow to adjust the spacing between every single metering unit by performing a quick and easy operation on the bars.

Next subsections specify the possible adjustments to perform depending on the type of frame VARIANT IDRA assembled on the machine.



MARKS ON THE BARS DEFINE THE CORRESPONDING DISTANCE (cm) BETWEEN CONSECUTIVE UNITS.

6.5.4.5 VARIANT V300/7-S 50-80

This model allows to adjust the spacing of:
- **7 ROWS** at 50, 55, 60, 65, 70, 75 and 80 cm



ADJUST THE DISTANCE BETWEEN METERING UNITS ONLY WHEN THE MACHINE IS COMPLETELY CLOSED, OTHERWISE THE MACHINE COULD BE DAMAGED.

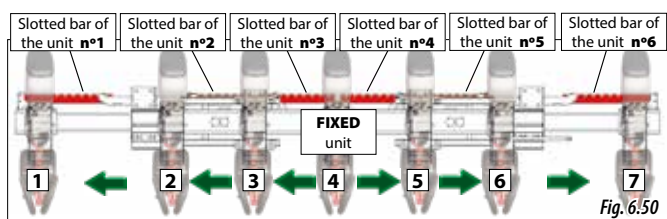

To adjust the row spacing, operate the bars' aperture stops (A, Fig. 6.51) as indicated below:

- 1- Remove the metering unit's pins (B, Fig. 6.51) and the aperture stops (A, Fig. 6.51).
- 2- Place the aperture stops of the units at the desired position (45, 50, 55 or 60) using the pins.
- 3- Open the machine using the hydraulic system: the row spacing will be the selected one.

6.5.5.1 IDRA300/8 40-75 AND IDRA330/8 45-80

This model allows to adjust the spacing between:

- **8 ROWS** at 40, 45, 50, 55, 60, 65, 70 and 75 cm (in frame model **IDRA300/8 40-75**).
- **8 ROWS** at 45, 50, 55, 60, 65, 70, 75 and 80 cm (in frame model **IDRA 330/8 45-80**).



ADJUST THE DISTANCE BETWEEN METERING UNITS ONLY WHEN THE MACHINE IS COMPLETELY CLOSED, OTHERWISE THE MACHINE COULD BE DAMAGED.



THIS FRAME MODEL HAS SOME FIXED STOPS ASSEMBLED (A, FIG. 6.52). THEY HAVE TO BE PLACED ALWAYS IN THE BARS' NOT-MARKED SLOTS (GREEN slotted bars FIG. 6.52). THEY MUST NEVER BE REMOVED UNDER ANY CIRCUMSTANCES, OTHERWISE THE MACHINE COULD BE DAMAGED.

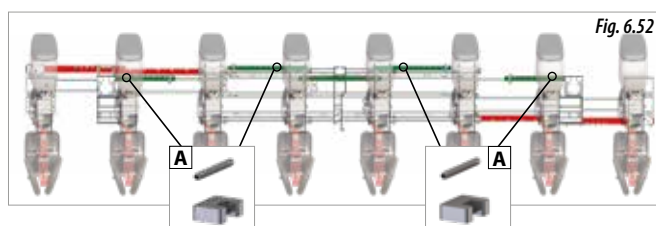

To adjust the row spacing, the **6 row spacing** (A, Fig. 6.53) stops must be placed at the desired spacing marked on the unit's slotted bars (red slotted bars Fig. 6.52). To adjust the row spacing, follow these steps:

- 1- Remove the pin (B, Fig. 6.53)
- 2- Remove the aperture stop (A, Fig. 6.53).
- 3- Place the aperture stop at the desired spacing.
- 4- Place the pin in the hole to lock the stop.
- 5- Open the machine using the hydraulic system: the row spacing will be the selected one.

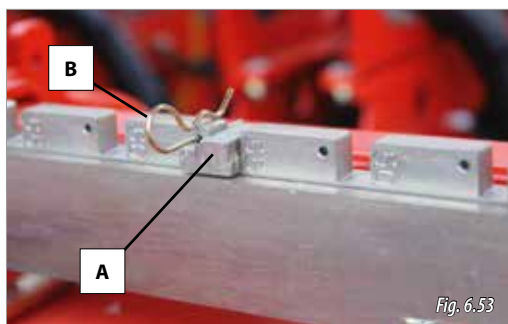

PLACE ALL THE STOPS **AT THE SAME ROW SPACING** MARKED ON THE SLOTTED BARS, OTHERWISE THE MACHINE COULD BE DAMAGED.

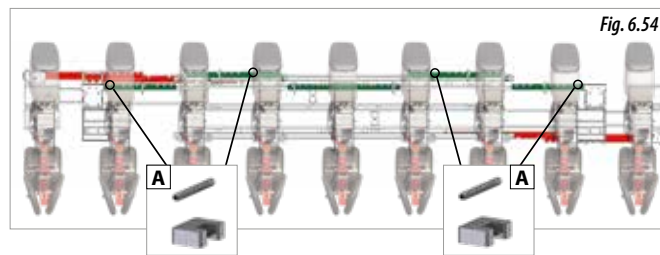

To adjust the row spacing, the **6 row spacing** (A, Fig. 6.55) stops must be placed at the desired spacing marked on the unit's slotted bars (red slotted bars Fig. 6.54). To adjust the row spacing, follow these steps:

- 1- Remove the pin (B, Fig. 6.55).
- 2- Remove the aperture stop (A, Fig. 6.55).
- 3- Place the aperture stop at the desired spacing.
- 4- Place the pin in the hole to lock the stop.
- 5- Open the machine using the hydraulic system: the row spacing will be the selected one.

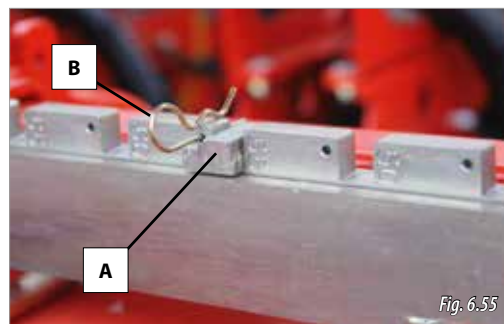

PLACE ALL THE STOPS **AT THE SAME ROW SPACING** MARKED ON THE SLOTTED BARS, OTHERWISE THE MACHINE COULD BE DAMAGED.



TO ADJUST THE MACHINE TO 8 ROWS, THE CENTRAL METERING UNIT HAS TO BE EXCLUDED (Fig. 6.56), SEE SECTION 6.7 EXCLUDING A METERING UNIT.

6.5.5.2 IDRA300/9 9F40-55 8F65-75 AND IDRA330/9 9F45-60 8F70-80

This model allows to adjust the spacing between:

- **8 ROWS** at 40, 45, 50 and 55 or **9 ROWS** at 65, 70 y 75 cm (in frame model **IDRA300/9 9F40-55 8F70-80**).
- **8 ROWS** at 45, 50, 55 and 60 or **9 ROWS** at 70, 75 and 80 cm (in frame model **IDRA330/9 9F40-55 8F65-75**).



ADJUST THE DISTANCE BETWEEN METERING UNITS ONLY WHEN THE MACHINE IS COMPLETELY CLOSED, OTHERWISE THE MACHINE COULD BE DAMAGED.



THIS FRAME MODEL HAS SOME FIXED STOPS ASSEMBLED (A, FIG. 6.54). THEY HAVE TO BE PLACED ALWAYS IN THE BARS' NON-MARKED SLOTS (in GREEN, FIG. 6.54). THEY MUST NEVER BE REMOVED UNDER ANY CIRCUMSTANCE, OTHERWISE THE MACHINE COULD BE DAMAGED.

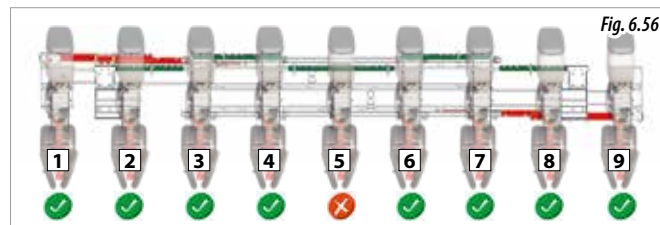

6.5.6 FOLDING MACHINE

To adjust the spacing between metering units in folding machines, it is necessary to operate on:
THE CENTRAL FRAME (A, Fig. 6.57).
The FOLDING PARTS (B, Fig. 6.57).

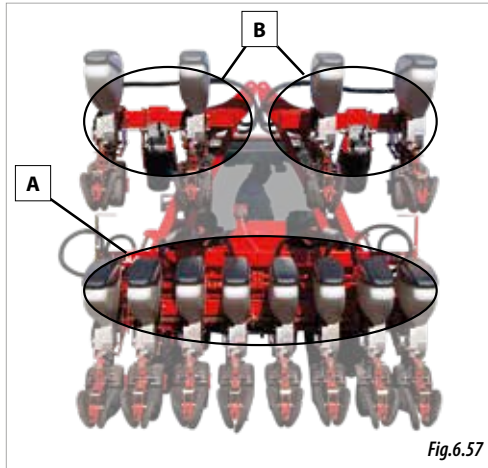

Fig.6.57

6.5.6.1 FIXED FOLDING MACHINE

To adjust the row spacing of the central frame and the folding parts, follow as indicated in section 6.5.1 FIXED MACHINE.

6.5.6.2 VARIANT MANUAL FIXED FOLDING MACHINE

To adjust the row spacing of the central frame and the folding parts, follow as indicated in section 6.5.2 VARIANT MANUAL FIXED MACHINE.

6.5.6.3 TELESCOPIC FOLDING MACHINE

The row spacing of this machine can not be adjusted.

6.5.6.4 IDRA FOLDING MACHINE

The row spacing of this machine can not be adjusted.

6.5.6.5 GEA FOLDING MACHINE

To adjust the row spacing of the central frame and the folding parts, follow the indications in section 6.5.1 FIXED MACHINE.

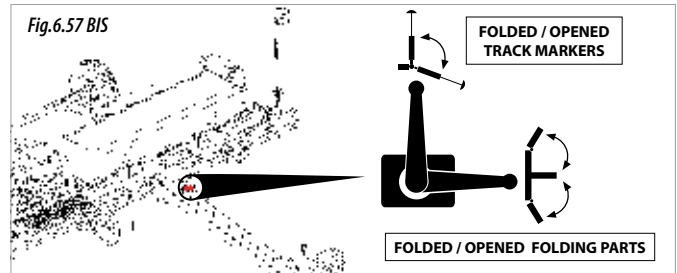

WITH THE MACHINE FOLDED, DO NOT UNFOLD THE TRACK MARKERS BEFORE FOLDING THE MACHINE, MAKE SURE THAT THE TRACK MARKERS ARE FOLDED. POSITION THE SHUT OFF VALVE CORRECTLY AS INDICATED BY THE ADHESIVE LABEL (FIG. 6.57 BIS).

6.6 DRIVE WHEELS

There are two types of drive wheels:

- Front drive wheels, which are fixed in height (see section 6.6.1).
- Rear drive wheels, which are adjustable in height (see section 6.6.2).



THE DRIVE WHEELS HAVE TO BE ASSEMBLED BETWEEN 2 ROWS. IT IS PREFERABLE THAT THEY COINCIDE WITH THE TRACTOR'S WHEELS.

6.6.1 FRONT DRIVE WHEELS, FIXED IN HEIGHT

The position of the drive wheel needs to be adjusted so that it runs between 2 planting rows. To adjust its position, follow these steps:

- 1- Raise the planter until the drive wheels are not in contact with the ground.
- 2- Loosen the nuts in order to shift the wheel.
- 3- Place the wheel at the desired position.
- 4- Tighten strongly the nuts.



Fig. 6.58



IN PLANTERS EQUIPPED WITH FRAME OF TYPE TELESCOPIC, VARIANT AND VARIANT IDRA, ADJUST THE DRIVE WHEELS WHEN THE MACHINE IS OPEN.



IN MACHINE VERSIONS TELESCOPIC, VARIANT AND VARIANT IDRA, PERFORM THE ADJUSTMENTS ONLY WHEN THE TRACTOR'S ENGINE IS OFF AND THE IGNITION KEY HAS BEEN REMOVED.

6.6.2 REAR DRIVE WHEELS, ADJUSTABLE IN HEIGHT

The position of the drive wheels needs to be adjusted so that each one runs between 2 planting rows. To adjust their position, follow these steps:

- 1- Raise the planter until the drive wheels are not in contact with the ground.
- 2- Loosen the locking lever (1, Fig. 6.59)
- 3- Turn the crank (2, Fig. 6.59) until the wheel is placed at the desired height. To adjust the wheel use the graduated scale (3, Fig. 6.59).
- 4- Lock the wheel's position using the lever (1, Fig. 6.59).

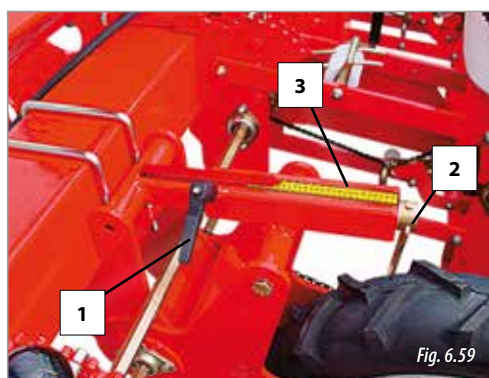

Fig. 6.59

6.7.1 MANUAL EXCLUSION OF THE TRANSMISSION

While planting, it is possible to manually exclude the transmission of one or more metering units so that they stop planting.



THIS OPERATION MUST ONLY BE PERFORMED WHEN THE PARKING BRAKE IS SET.

To **DISCONNECT THE TRANSMISSION**:

- 1- Shift the clutch by pulling it until the knob gets fixed at the exclusion position (Fig. 6.60).

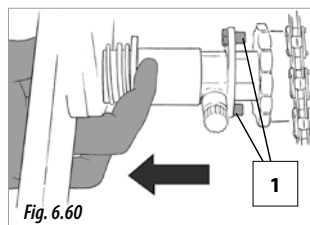

Fig. 6.60

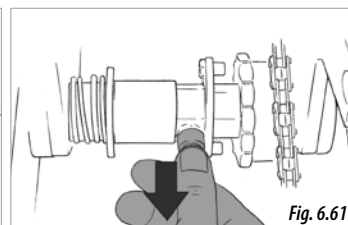

Fig. 6.61

To **RECONNECT THE TRANSMISSION**:

- 1- Pull the knob out slightly (Fig. 6.61) and the clutch will return to its transmission position.
- 2- Check that the screws (Fig. 6.60) have engaged correctly. If not, move the clutch until they engage.

6.7.2 AUTOMATIC ROW EXCLUSION (OPTIONAL)

Automatic row exclusion is performed using an electronic controller. It contains the following parts:

6.7 EXCLUDING A METERING UNIT

To exclude a metering unit so that it stops planting, follow these steps:

- 1- **INDIVIDUAL EXCLUSION OF THE TRANSMISSION** for each element
 - **MANUAL** (see section 6.7.1 MANUAL EXCLUSION OF THE TRANSMISSION).
 - **AUTOMATIC** (see section 6.7.2 AUTOMATIC EXCLUSION OF THE TRANSMISSION – OPTIONAL)
- 2- **RAISE THE METERING UNIT** to be excluded (see section 6.7.3 RAISING THE UNIT)

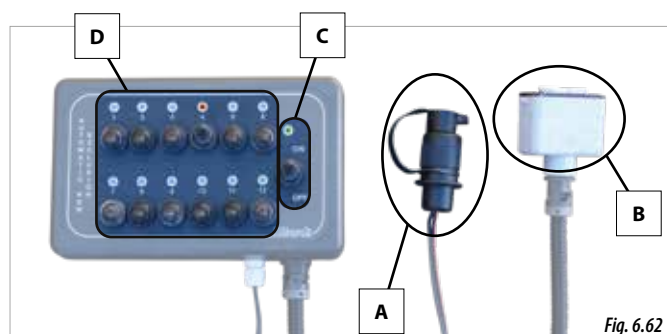
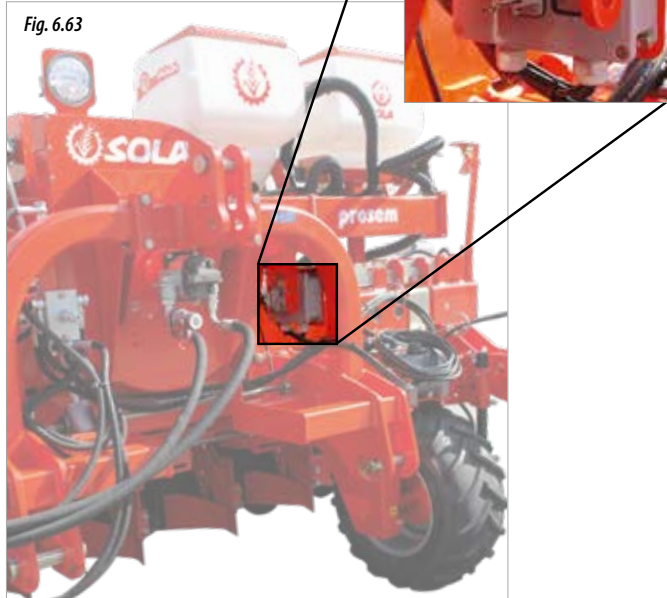

Fig. 6.62



- POWER PLUG (A, Fig. 6.62). It needs to be plugged into the tractor's PTO.
- CONTROLLER'S PLUG (B, FIG. 6.62). It needs to be plugged to the planter's relay box (Fig. 6.63).
- STARTING SWITCH (C, Fig. 6.62). It has two positions:
 - ON / OFF**
- 12 EXCLUSION SELECTORS for the metering units (D, Fig. 6.62). It has two positions:

EXCLUDE: switch the selector upwards, a red light will appear above the selector. It indicates that the metering unit has been excluded.

INCLUDE: switch the selector downwards, the red light above the selector will disappear. This indicates that the unit is starting to plant.



EACH SELECTOR CORRESPONDS TO A METERING UNIT. THE SELECTOR NUMBER ONE CORRESPONDS TO THE FAR LEFT METERING UNIT (IN THE FORWARD DIRECTION). THE REMAINING SELECTORS ARE CONSECUTIVE TO THE UNITS THAT ARE ASSEMBLED ON THE MACHINE.



NOT ALL THE SELECTORS WORK. ONLY THE SELECTORS PROVIDED WITH AN ELECTRIC ENGINE IN THE UNIT'S TRANSMISSION ARE OPERATIVE. THE MAXIMUM NUMBER OF EXCLUSION SELECTORS WHICH ARE OPERATIVE IS THE NUMBER OF METERING UNITS OF THE MACHINE.



TO CONNECT THE AUTOMATIC ROW EXCLUSION SYSTEM TO A GPS OR A PLANTING CONTROLLER, IT IS NECESSARY AN EXTRA CABLE (CODE: EO-101708). THE ELECTRICAL CONNECTION DIAGRAM IS SUPPLIED WITH THE CABLE.

6.7.3 RAISING THE UNIT

To **RAISE/EXCLUDE THE UNIT:**

- 1- When the planter is in a raised position, couple the SPRING to position B. After performing this operation, the lever (1) will move to the other end (Fig. 6.65).
- 2- Place a wooden block of about 20 cm high under the wheels. This is used for the depth control of each unit to be excluded.
- 3- Lower the planter onto the ground so that the units TO BE EXCLUDED become locked.

To **LOWER/INCLUDE THE UNIT:**

- 1- When the planter is in raised position, couple the SPRING to the position A.
- 2- Place a wood block of about 20 cm high under the wheels. This is used for the depth control of each unit to be included.
- 3- Lower the planter onto the ground in order to INCLUDE the unit (Fig. 6.64).

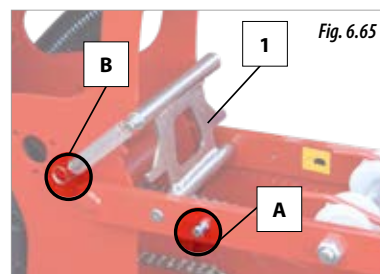
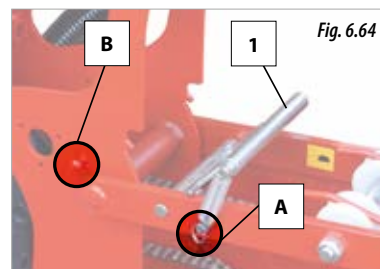

6.8 PLANTING DEPTH



PERFORM THIS OPERATION TO EACH METERING UNIT AND ONLY WITH THE MACHINE IN RAISED POSITION.



TO SET THE PLANTING DEPTH USE THE GRADUATED SCALE. EACH VALUE OF THE SCALE REFERS TO THE PLANTING DEPTH IN CENTIMETERS. FOR EXAMPLE, IF WE SET 5, PLANTING DEPTH WILL BE 5 CM. WE RECOMMEND NOT TO OVERPASS VALUES OVER 7. IN CASE IS NEEDED, THE "DEEP PLANTING KIT" MUST BE INSTALLED (ASK YOUR DEALER). DEPENDING ON THE FIELD CONDITIONS VALUES MENTIONED ABOVE CAN CHANGE. REAL DEPTH CONTROL TEST MUST BE CARRIED OUT ON THE FIELD BEFORE START PLANTING.



IMPORTANT: WHEN SETTING THE PLANTING DEPTH DO NOT OVERPASS 8 CM VALUE.

6.8.1 ADJUSTING PROSEM K

To adjust the planting depth of this metering unit, follow these steps:

- 1- Remove the pin (1, Fig. 6.66) to free the crank (2, Fig. 6.66).
- 2- Turn the crank to set the desired planting depth. For this purpose, use the depth indicator (3, Fig. 6.66).
- 3- Once the planting depth has been set, lower the crank (2, Fig. 6.66) and place the pin (1, Fig. 6.66) to fix the planting depth.

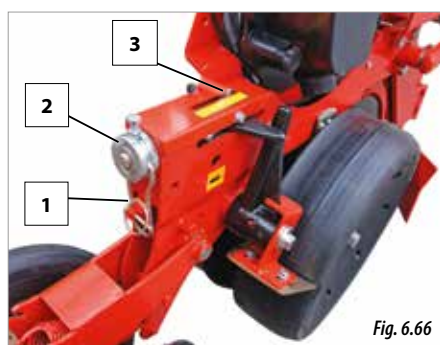

Fig. 6.66

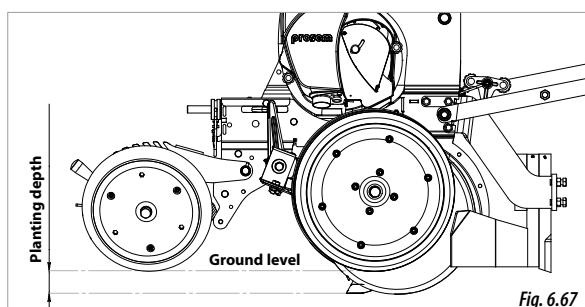

Fig. 6.67

6.8.2 ADJUSTING PROSEM P

In model P, unlike model K, the press wheel is in charge of adjusting the planting depth. Therefore, to adjust the planting depth follow these steps:

- 1- Loosen the securing lever (4, Fig. 6.68)
- 2- Turn the crank (5, Fig. 6.68) to set the desired planting depth. For this purpose, use the indicator and the scale (6, Fig. 6.68) which is graduated from 0 to 10.
- 3- Fix the planting depth by pressing the lever (4, Fig. 6.68).

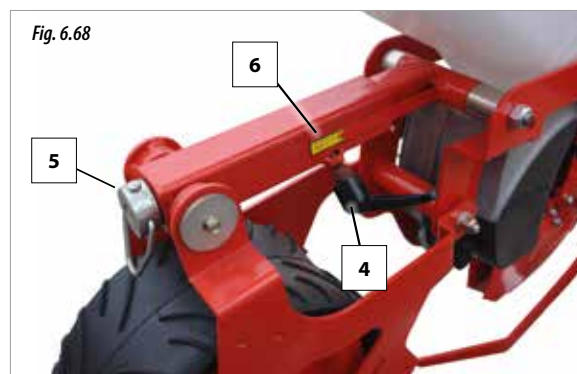

Fig. 6.68

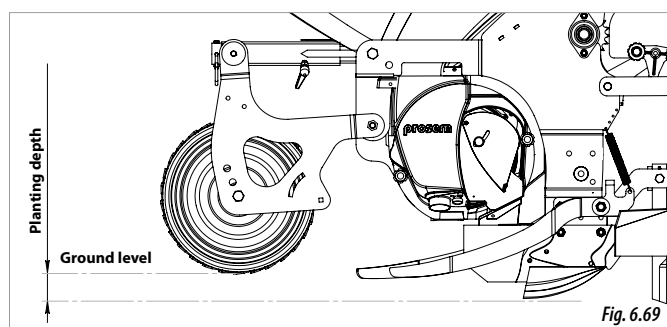

Fig. 6.69

6.9 SCRAPER PROSEM K

Metering unit PROSEM K is equipped with scrapers in:

- Depth adjustment wheels (A, Fig. 6.70).
- Seed discs (B, Fig. 6.71).

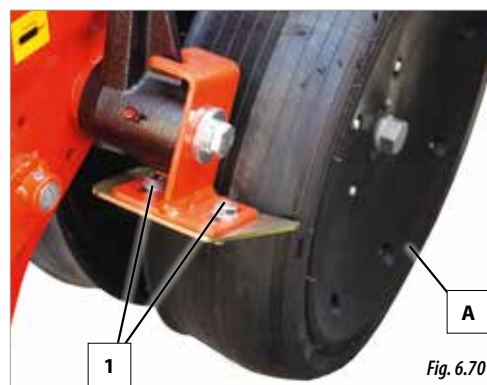
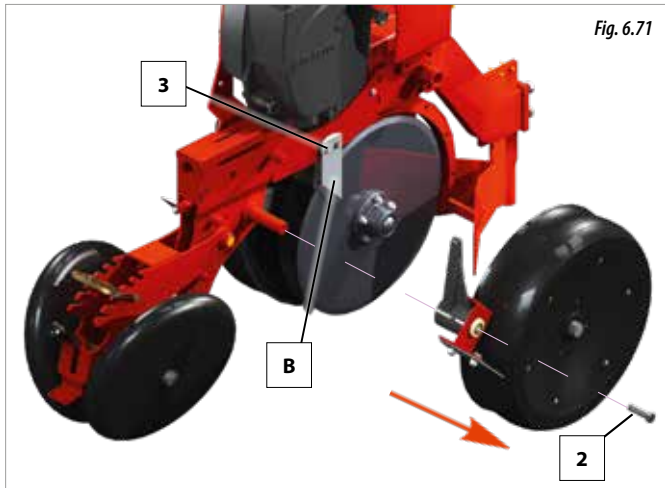

Fig. 6.70



To adjust the scrapers of the depth adjustment wheels, operate on the screws (1, Fig. 6.70). They need to be adjusted to be at 3-4 mm away from the wheel.



THE SCRAPER MUST NEVER BE IN CONTACT WITH THE DEPTH CONTROL WHEELS.

Metering unit K is equipped with two seed discs. Each one has two scrapers, one exterior and one interior.

To adjust the seed disc's scrapers, follow these steps:

- 1- Take apart the depth adjustment wheel using the screw (2, Fig. 6.71).
- 2- Loosen the screws (3, Fig. 6.71).
- 3- Place the interior and the exterior scrapers so that they keep a distance of 2 millimeters from the seed disc, without being in contact with it.
- 4- Repeat the former steps to adjust the two scrapers of the seed disc placed on the other side of the metering unit.



PERFORM THIS OPERATION WITH THE PLANTER IN RAISED POSITION.

6.10 PRESSURE OF THE METERING UNIT ONTO THE GROUND

The pressure device assembled in each metering unit allows to adapt the machine to several kinds of terrain. The role of this device is to increase or reduce the unit's weight in order to modify the unit's penetration ability.

6.10.1 PRESSURE OF THE METERING UNIT K/P

Depending on the machine model, the systems can be:
 - LEVER (see section 6.10.1.1 LEVER SYSTEM).
 - SPINDLE (see section 6.10.1.2 SPINDLE SYSTEM).

6.10.1.1 LEVER SYSTEM

Operate on the lever (A, Fig. 6.72) to modify the pressure of the unit onto the ground. Depending on the lever's position, the pressure exerted by the metering unit will increase or reduce. The following table shows the pressure in Kg for each lever's position (Fig. 6.73).

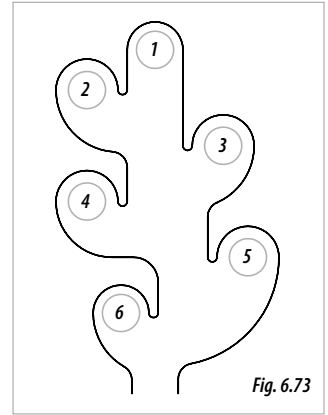

WHEN CHANGING THE LEVER'S POSITION, HOLD AND MOVE IT TIGHTLY.

POSITION	PRESSURE (kg _f)	
	MODEL K	MODEL P
1	103	85
2	109	91
3	115	97
4	123	105
5	131	113
6	139	121

6.10.1.2 SPINDLE SYSTEM

Operate the crank (A, Fig. 6.73.a) to modify the pressure of the unit on the ground. Depending on the crank's position, the pressure exerted by the metering unit will be increased or reduced. The following table shows the working pressures depending on the position of the crank (Fig. 6.73.b).

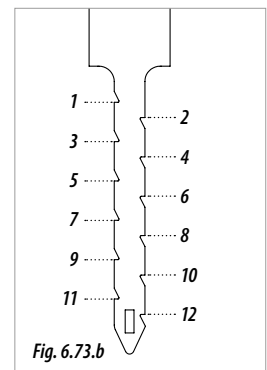
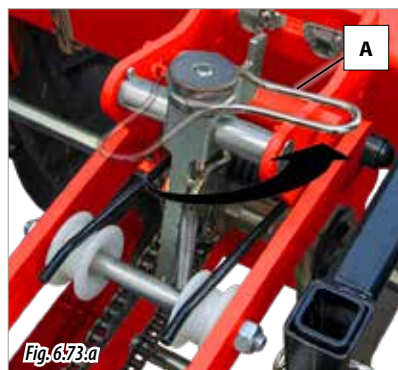

POSITION	PRESSURE (kg _f)	
	MODEL K	MODEL P
1	104	86
2	105	87
3	110	92
4	114	96
5	118	100
6	120	102
7	124	106
8	126	108
9	128	110
10	134	116
11	140	122
12	144	126



IMPORTANT: LOCK THE CRANK OF EACH OF THE METERING UNITS (Fig. 6.73.c), OTHERWISE THEY MAY LOSE PRESSURE DURING USE OR TRANSPORTATION OF THE MACHINE.



6.10.2 PRESSURE OF THE BASIC UNIT

Operate the nut (B, Fig. 6.74) to modify the pressure of the unit onto the ground. Tighten the nut to increase the pressure and loosen it to reduce the pressure.



TO ADJUST THE METERING UNITS SO THAT THEY HAVE THE SAME PRESSURE, THE EASIEST WAY IS TO MEASURE THE SCREW'S LENGTH IN EVERY UNIT (FIG. 6.74).

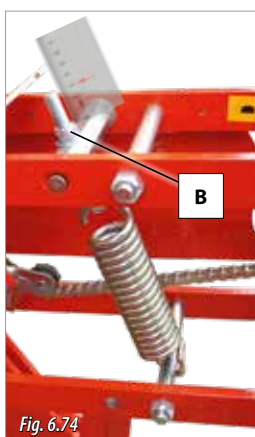

6.11 CLOSING THE FURROWS

Adjusting the way the furrows are closed depends on the type of metering unit assembled on the planter (type K or P). The closing devices are:

- V-SHAPED REAR PRESS WHEELS (SEE 6.11.1 V-SHAPED REAR PRESS WHEELS – PROSEM K).
- SEED COVERING DEVICE AND PRESS WHEEL (see 6.11.2 FURROW-COVERER – PROSEM P).

6.11.1 V-SHAPED REAR PRESS WHEELS – PROSEM K

The function of the seed-covering device PROSEM K is to close and press the furrow created by the unit's seed discs.



WHEN **THE TERRAIN'S SLOPE IS LATERAL** IN RELATION TO THE FORWARD DIRECTION OF THE MACHINE, IT IS RECOMMENDED TO USE PRESS WHEELS WITH SHORT CONNECTION ROD (FIG. 6.76). OTHERWISE, IF PRESS WHEELS WITH LONG CONNECTION ROD ARE USED (FIG. 6.75), THE SEEDS MAY NOT BE COVERED.

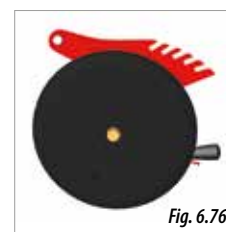
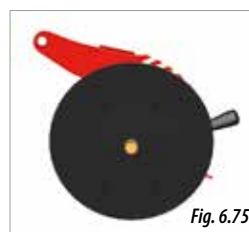

WHEN **THE TERRAIN IS ROCKY**, IT IS RECOMMENDED TO USE OUT-OF-PHASE PRESS WHEELS (FIG. 6.77). THEY ARE DESIGNED TO PREVENT THE STONES COINCIDING WITH THE SEEDBED, GETTING STUCK BETWEEN THE TWO WHEELS.

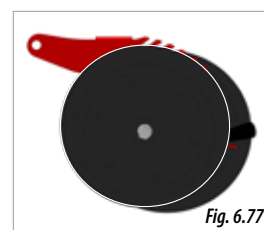

WHEN THE TERRAIN MEETS BOTH PREVIOUS CONDITIONS (**ROCKY TERRAIN WITH LATERAL SLOPE**), IT IS RECOMMENDED TO USE OUT-OF-PHASE PRESS WHEELS WITH SHORT CONNECTION ROD. (FIG. 6.78)

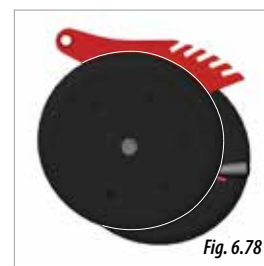

The furrow closing wheels admit the following adjustments (Fig. 6.79):

- Working **WIDTH**, depending on the planting depth.
- **PRESSURE** exerted by the wheel onto the terrain.
- **BEARING ANGLE** of both wheels, unless using out-of-phase press wheels, since their bearing angle can not be adjusted.



Fig. 6.79



THE FURROW CLOSING WHEELS NEED TO BE CLEANED PERIODICALLY.

6.11.1.2 PRESSURE ONTO THE SEED

To adjust the pressure exerted by the V-shaped press wheel, pull the fixing handle (1, Fig. 6.82) and place it at the suitable position for the type of terrain to be planted.

Next table shows the exerted pressure depending on the position of the fixing handle (Fig. 6.83):

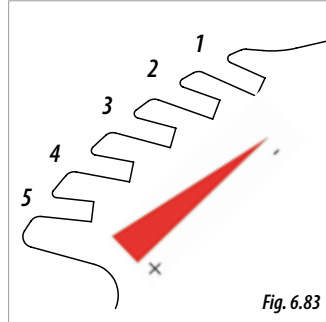

Fig. 6.83



Fig. 6.82

POSITION	PRESSURE (kg,)
1	18
2	20
3	22
4	26
5	28

6.11.1.1 WHEEL'S WORKING WIDTH

Depending on the planting depth, the working width of the furrow closing wheels needs to be adjusted so that they cover and compact the seed properly:

- **PLANTING DEPTH LESS THAN 2 CM** or when **THE FURROW STAYS OPEN:** the shaft sleeves A (narrow) and B (wide) need to be assembled as shown in picture 6.80.
- **PLANTING DEPTH MORE THAN 2 CM:** the shaft sleeves A (narrow) and B (wide) need to be assembled as shown in picture 6.81.

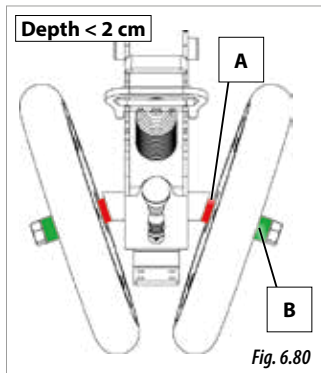

Fig. 6.80

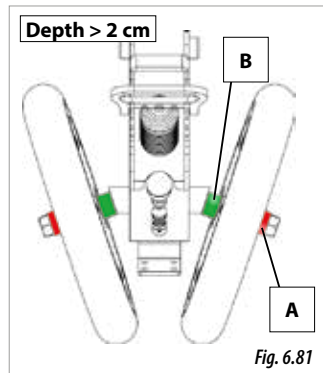

Fig. 6.81

(*) This adjustment is valid for standard rubber press wheels of 1" and 2".



IMPORTANT: BE SPECIALLY CAREFUL WHEN DISASSEMBLING THE WHEELS, SINCE THE THREAD HAS A DIFFERENT DIRECTION DEPENDING ON THE SIDE TO PREVENT THE SCREW FROM LOOSENING DURING WORK.



ON TILLED TERRAINS, THE PRESSURE SHOULD BE REDUCED. ON THE OTHER HAND, ON NOT VERY TILLED TERRAINS, THE PRESSURE SHOULD BE INCREASED.



WHEN CHANGING THE POSITION OF THE FIXING HANDLE, PULL IT STRONGLY.

6.11.1.3 BEARING ANGLE

The wheel's bearing angle should be adjusted depending on the type of terrain to be planted.

To change the bearing angle of the press wheels onto the terrain, it is necessary to push the position lever (Fig. 6.84) inwards and shift it to place it at the correct position. Check that the position lever is fixed at the desired position.



Fig. 6.84

Position lever's adjustments:

POSITION	ANGLE	WHEEL'S OPENING
1	2,8	OPEN
2	2,2	OPEN
3	-7,2	CLOSED
4	-12,2	CLOSED

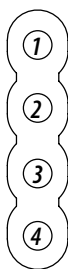

WHEEL'S BEARING ANGLE IN THE TABLE IS SHOWN IN RELATION TO THE FORWARD DIRECTION (FIG. 6.85 AND 6.86).

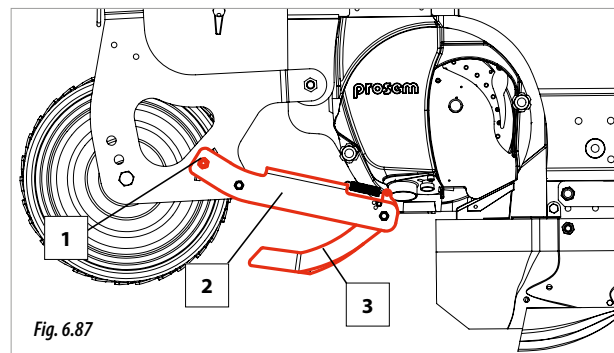
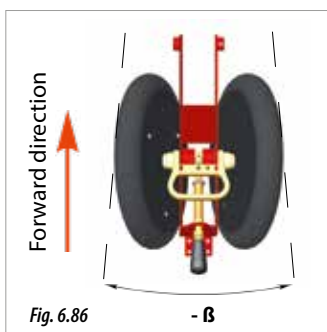
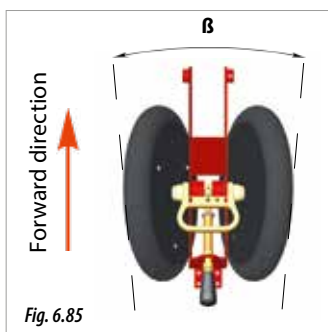

Fig. 6.87

The seed-covering can be adjusted by modifying its height above terrain. To perform the adjustment follow these steps:

- 1- Loosen the screw (1, Fig. 6.87).
- 2- Shift the lever (2, Fig. 6.87) to the desired position.
- 3- Fix the seed-covering arm by tightening the screw (1, Fig. 6.87).



THE COVERING DEVICE (3, FIG. 6.87) NEEDS TO BE PARTIALLY BURIED SO THAT THE SEED-COVERING CAN WORK NORMALLY.



BEFORE ADJUSTING THE SEED-COVERING DEVICE, FIRST ADJUST THE METERING UNIT'S PLANTING DEPTH (see section 6.8.2 ADJUSTING PROSEM P).

6.11.2 FURROW-COVERER – PROSEM P

Closing the furrows created by the metering unit PROSEM P is performed by the seed-covering device and the press wheel FARMFLEX

There are two types of seed-covering device depending on the model of PROSEM P:

- SHORT ARM, in PROSEM P WITH HIGH SHARE
- LONG ARM, in PROSEM P



ONLY THE SEED-COVERING DEVICES ARE ADJUSTABLE. THE WHEEL FARMFLEX ONLY PRESSES THE TERRAIN WHERE THE SEED HAS BEEN PLACED.

6.11.2.1 ADJUSTING THE FURROW-COVERER PROSEM P HIGH SHARE

PROSEM P HIGH SHARE is provided has two seed-covering devices, one on each side of the metering unit. Each seed-covering device consists of one arm (2, Fig. 6.87) and a covering device (3, Fig. 6.87).

6.11.2.2 ADJUSTING THE FURROW-COVERER PROSEM P

The pressure of the seed-covering device (4, Fig. 6.88) can be adjusted using the spring (5, Fig. 6.88). Therefore when the spring's position is modified, the strength it exerts on the ground is also modified.

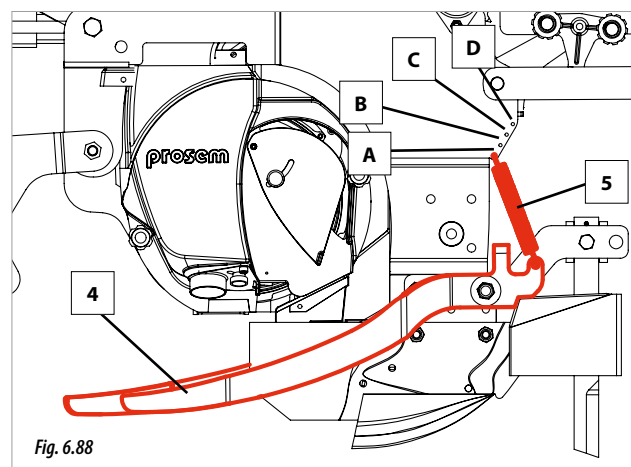

Fig. 6.88

Pressure exerted by the spring depending on the position is shown in the next table:

POSITION	PRESSURE (kg _f)
A	1,5
B	1,8
C	2,2
D	2,5



IN ORDER FOR THE SEED-COVERING DEVICE TO WORK PROPERLY, IT NEEDS TO BE PARTIALLY BURIED.

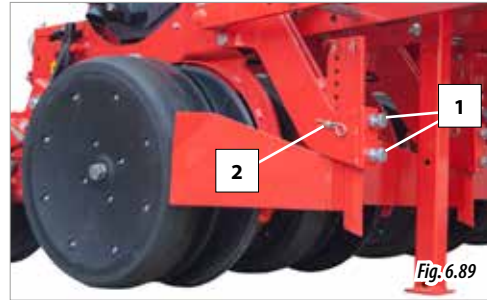

CLOD REMOVERS CAN BE REPLACED BY DISC OPENERS OR FURROW-OPENER BLADES OR FURROW'S RESIDUE ROTARY CLEANERS.

- METERING UNITS P:

- 1- Loosen the screw (B, Fig. 6.90) to free the blade.
- 2- Place the blade at the desired depth and fix it by tightening the screw (B, Fig. 6.90).
- 3- Loosen the screw (C, Fig. 6.90) to free the clod remover.
- 4- Shift the clod remover along the blade until it reaches the desired height.
- 5- Fix the clod remover to the blade by tightening the screw (C, Fig. 6.90).

6.12 OPENING COMPONENTS

The depth at which the opening components are buried depends on:

- The planting depth of the metering unit which has the opening component assembled.
- The opening component's adjustment.



ADJUST THESE COMPONENTS ONLY AFTER ADJUSTING THE METERING UNIT'S PLANTING DEPTH.



IN THE CASE OF NO-TILL FARMING, THE TURBO DISC OPENERS NEED TO BE ASSEMBLED ON THE PLANTER'S FRAME AND NEED TO COINCIDE WITH EACH METERING UNIT'S SOWING ROW. THE FURROW-OPENER BLADE NEEDS TO BE ASSEMBLED ON THE METERING UNITS (see sections 6.12.3 ADJUSTING THE FURROW-OPENER BLADE and 6.14 TURBO DISC OPENER).

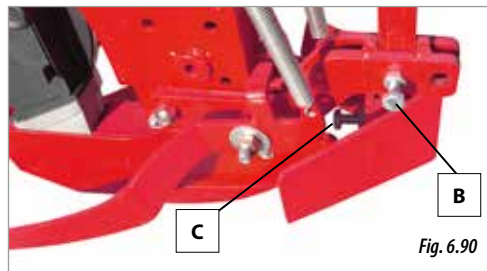

6.12.1 ADJUSTING THE BLADE AND THE CLOD REMOVER

The depth at which the blade and the clod remover are going to be buried depends on the type of metering unit:



ATTENTION: ADJUST THE BLADE 1 OR 2 CM BELOW PLANTING DEPTH.

- METERING UNITS K:

- 1- Loosen the screws (1, Fig. 6.89) to free the blade and the clod remover.
- 2- Remove safety ring and securing bolt (2, Fig.6.89).
- 3- Place the blade and the clod remover at the desired height.
- 4- Tighten the screws (1, Fig. 6.89) to fix both components.

6.12.2 ADJUSTING THE DISC FURROW OPENER IN UNIT PROSEM K (OPTIONAL)

To adjust the disc opener's working depth:

- 1- Remove the nut (1, Fig. 6.91), hold the disc with one hand and use the other one to remove the screw.
- 2- Place the disc at the desired position, A, B or C.
- 3- Place the screw at the same position as the disc and fix it using the nut.

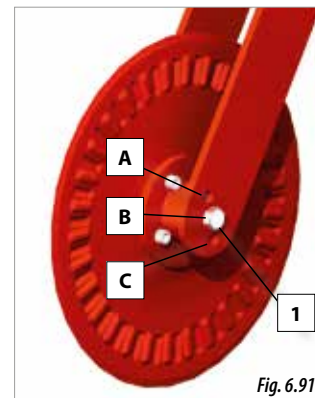

DISC OPENER'S POSITION	DEPTH (cm)
A	0
B	2
C	4

6.12.3 ADJUSTING THE FURROW-OPENER BLADE (OPCIONAL)

To adjust the blade's working depth:

- 1- Remove both the nut and the position screw (1, Fig. 6.92)
- 2- Loosen both the nut and the fixing screw (2, Fig. 6.92)
- 3- Place the blade at the desired height, adjust the height until one of the holes (A or B, Fig. 6.93) fits another one.

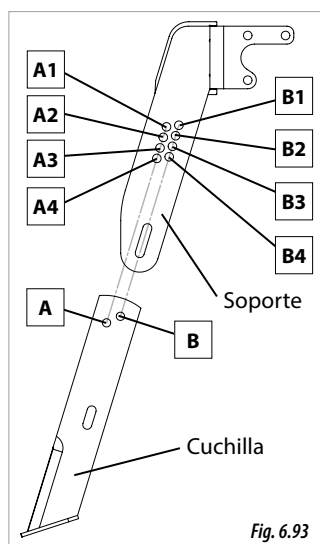

Fig. 6.93

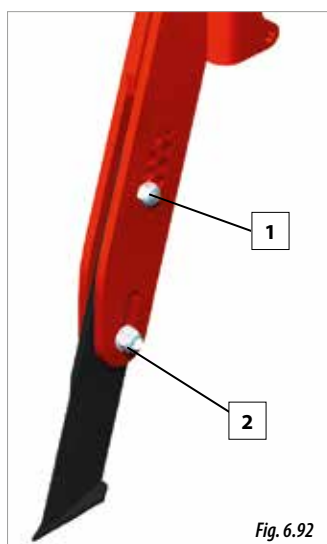

Fig. 6.92

BLADE'S POSITION	SUPPORT'S POSITION	DEPTH (CM)
A	A1	0
B	B1	0,7
A	A2	1,4
B	B2	2,2
A	A3	2,9
B	B3	3,6
A	A4	4,3
B	B4	5



The fixing screw (1, Fig. 6.93) needs to be placed at the same letter in both the blade and the support. Positions **A and B ARE NOT INTERCHANGEABLES**. To adjust the blade's working depth depending on the position of the position screw (1, Fig. 6.92), see next table and picture 6.93:

6.12.4 ADJUSTING THE FURROW'S RESIDUE ROTARY CLEANER IN PROSEM K METERING UNITS (OPTIONAL)

The furrow's residue rotary cleaners remove the residues of the sowing row. They need to work always superficially and can be adjusted in HEIGHT.



Fig. 6.94

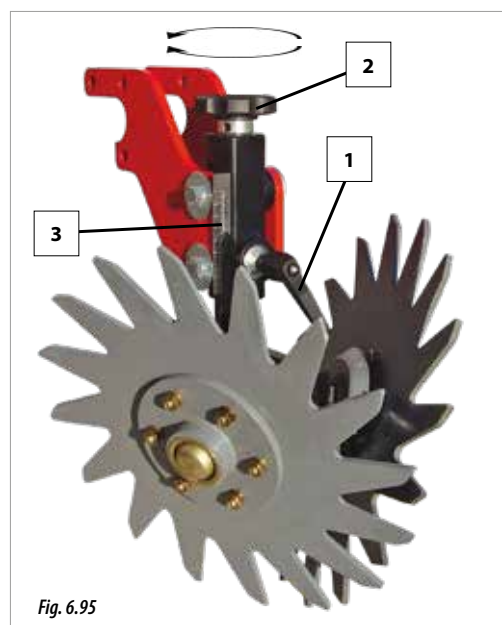

Fig. 6.95

To adjust the working height of the furrow's residue rotary cleaner, follow these steps:

- 1- Loosen the securing lever (1, Fig. 6.95)
- 2- Turn the knob (2, Fig. 6.95) until reaching the desired working height. To adjust the height, use the graduated scale (3, Fig. 6.95).
- 3- Fix the position using the lever (1, Fig. 6.95).



PERFORM THIS OPERATION ALWAYS WHEN THE PLANTER IS IN A RAISED POSITION.

6.13 FURROW'S RESIDUE ROTARY CLEANERS WITH PARALLELOGRAM (OPTIONAL)



PERFORM THIS OPERATION WITH THE MACHINE IN A RAISED POSITION.

The furrow's residue rotary cleaner pushes aside the residues present in the sowing row. They need always to work superficially pushing the residue aside.

Both the PRESSURE exerted onto the ground and the WORKING DEPTH STOP can be adjusted as follows:

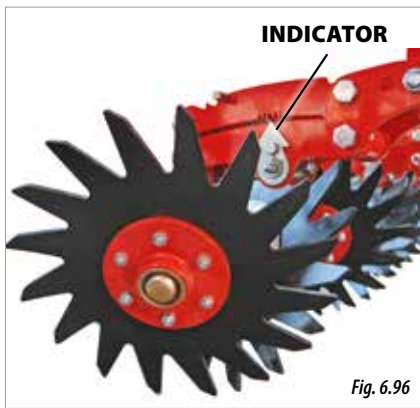

PRESSURE

To adjust the pressure of the furrow's residue rotary cleaner, pull the handle (3, Fig. 6.98) and place it at one of the 3 working positions (B1, B2 or B3, Fig. 6.97).

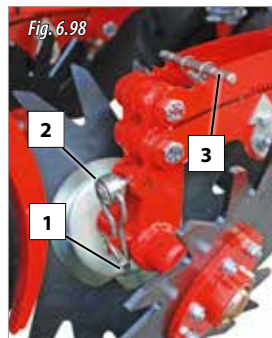
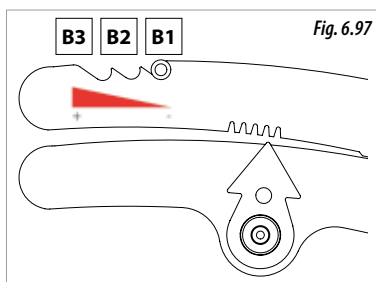

WORKING DEPTH STOP

To adjust the working depth stop, follow these steps:

- 1- Remove the pin (1, Fig. 6.98) to free the crank (2, Fig. 6.98).
- 2- Raise the furrow's residue rotary cleaner using one hand and use the other hand to turn the crank until the working depth stop is set at the desired position. For this purpose, use the depth indicator (3, Fig. 6.98).
- 3- Once the working depth stop has been set, lower the crank (2, Fig. 6.98) and place the pin back (1, Fig. 6.98) to lock the stop.

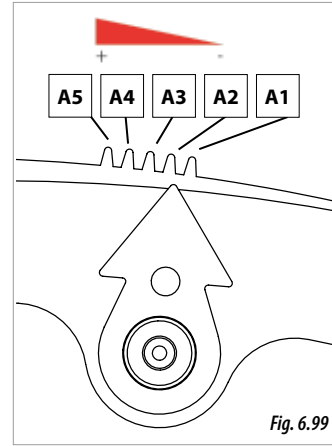

AFTER ADJUSTING, WORK THE GROUND SOME METRES TO CHECK THAT THE WORKING DEPTH STOP HAS BEEN CORRECTLY SET.

In the case of no-till farming on hard ground, it is not necessary to adjust the working depth stop, since the furrow's residue rotary cleaners will adapt to the terrain without turning the soil. In this case, the working depth stop needs to be inactive, set at position A5 (Fig. 6.99).

In the case of tilled ground, either adjust the working depth stop or exclude the furrow's residue rotary cleaners. To exclude them, set the working depth stop at position A1 (Fig. 6.99).

6.14 TURBO DISC OPENER (OPTIONAL)

Working depth of the turbo disc opener depends on two conditions:

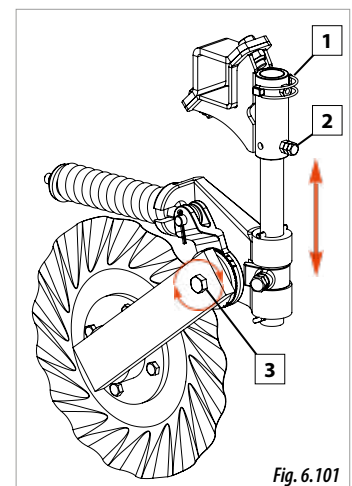
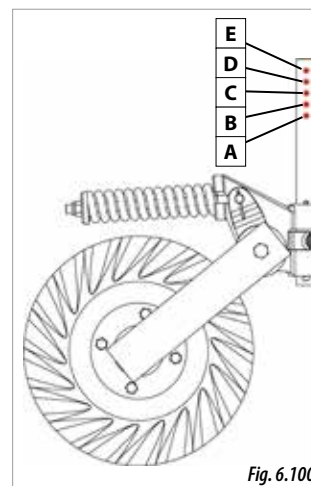

ROD'S HEIGHT

To adjust rod's height:

- 1- Remove the pin (1, Fig. 6.101)
- 2- Loosen the screw (2, Fig. 6.101)
- 3- Shift the rod to the desired position.
- 4- Place the pin (1, Fig. 6.101) in the desired hole (Fig. 6.100 to fix the position.
- 5- Finally, lock the rod using the screw and the lock nut (2, Fig. 6.101).

ROD'S POSITION	ROD'S DEPTH (cm)
A	0
B	2
C	4
D	6
E	8

POSITION OF THE CONNECTING ROD

To ensure correct adjustment of the turbo element, the connecting rod's angle (Fig. 6.103) needs to be adjusted:

- 1- Loosen the discs' fixing screw (3, Fig. 6.101)
- 2- Turn the discs until reach the desired angle of the connecting rod.
- 3- Tighten the fixing screw (3, Fig. 6.101).



WHEN ADJUSTING THE CONNECTING ROD'S ANGLE, ADJUST THE COG'S TOOTH SPACE SO THAT THEY STAY AS ALIGNED AS POSSIBLE (Fig. 6.102). IF MORE PRESSURE ONTO THE TERRAIN IS DESIRED, PLACE THE CONNECTING ROD IN A MORE VERTICAL POSITION.



THE SUPPORT WHERE THE TURBO DISC OPENER IS ASSEMBLED (1, Fig. 6.103) NEEDS TO WORK WITHOUT PENETRATING THE EARTH. FOR THIS PURPOSE, IT NEEDS TO BE ADJUSTED SO THAT IT WORKS IN A RAISED POSITION OF AT LEAST 2 CENTIMETRES (APPROXIMATELY) ABOVE THE GROUND (Fig. 6.103).



THE TURBO DISC OPENER NEEDS TO PENETRATE THE EARTH BETWEEN 1 AND 2 CENTIMETRES IN RELATION TO THE PLANTING DEPTH (Fig. 6.104). SEE SECTION 6.8 PLANTING DEPTH TO CALCULATE THE WORKING DEPTH OF THE DISC OPENER'S.

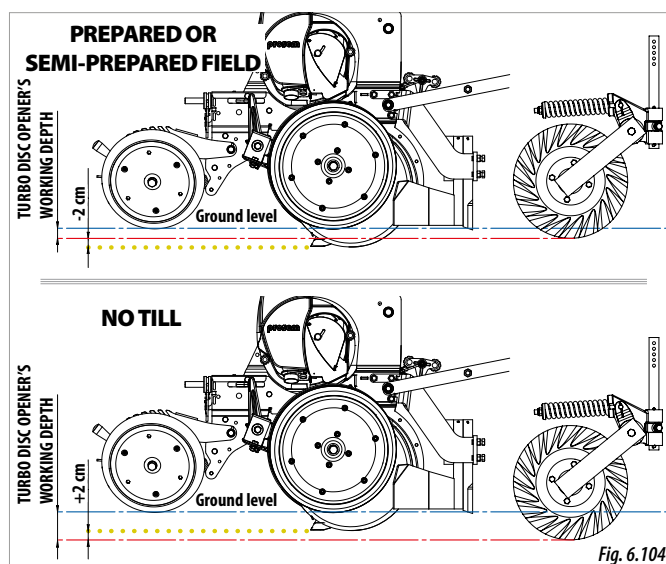

6.15 SEED PRESSING WHEEL PROSEM K (OPTIONAL)

Seed pressing wheels are placed between the wheels that control the working depth and the furrow closing wheels (Fig. 6.106). These wheels coincide with the seedbed where the seed is placed. Their function is to specify the depth at which the seed will be placed and compact the covering earth.

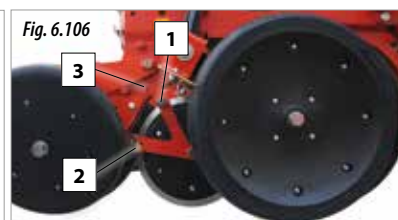
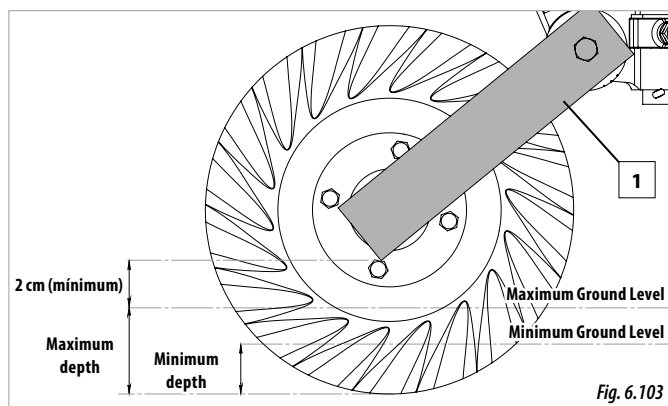

IMPORTANT: MAKE SURE THAT THE KNOB (1, FIG. 106) IS AT POSITION B BEFORE STARTING TO PLANT. OTHERWISE THE SEED PRESSING WHEEL WILL NOT WORK PROPERLY AND THIS COULD DAMAGE THE PLANTER.

This component can be excluded following these steps:

- 1- Raise the seed pressing wheel using one hand.
- 2- Use the other hand to pull the securing knob (1, Fig. 6.106) and place it at the exclusion point (3, Fig. 6.106). To fix this position, turn the securing knob to place the pin at position A (Fig. 6.107).

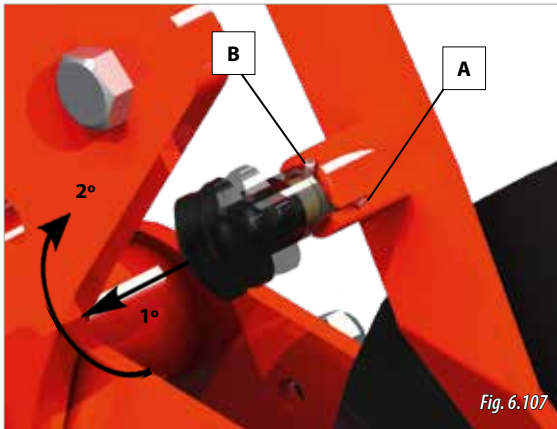

To unlock the seed pressing wheel from the exclusion position, pull the security knob (1, Fig. 6.106) and turn the pin until it reaches the position B (Fig. 6.107).



SEED PRESSING WHEEL'S SCRAPERS CAN BE ADJUSTED USING THE SCREWS (2, FIG. 6.106). ADJUST THE SCRAPERS AT 3-4 MM AWAY FROM THE WHEEL (MAKE SURE THE SCRAPER DOES NOT TOUCH THE WHEEL UNDER ANY CONDITION).

There are two types of seed pressing wheels:

- **RUBBER:** for delicate seeds that may break when compacting the earth. (Fig. 6.108).
- **STAINLESS STEEL:** for not very tilled or muddy terrains (Fig. 6.109).



IF THE METERING UNITS HAVE V-SHAPED PRESS WHEELS WITH SHORT CONNECTING ROD (SEE 6.11.1 V-SHAPED REAR PRESS WHEELS – PROSEM K), THEN THE METERING UNITS CANNOT BE EQUIPPED ALSO WITH SEED PRESSING WHEELS.

6.16 TRACK ERASER (OPTIONAL)

Track erasers can be adjusted:

- A. Horizontally, along their support.
- B. Vertically, so the working depth of the tine coulters can be adjusted.

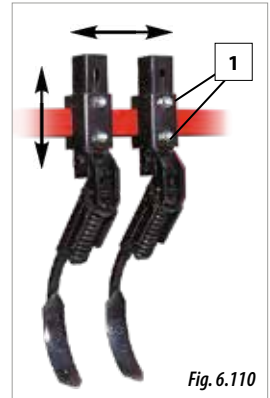

To modify the position of the track eraser:

1. Loosen the fixing nuts (1, Fig. 6.110).
2. Place the track eraser at the desired position.
3. Tighten the nuts to fix the position of the track eraser (1, Fig. 6.110).



ADJUST THE TRACK ERASERS HORIZONTALLY SO THAT THEY COINCIDE WITH THE TRACTOR'S WHEELS. ADJUST THE TRACK ERASERS VERTICALLY SO THAT THEIR WORKING DEPTH IS ENOUGH TO ERASE THE TRACTOR'S TRACKS (FIG. 6.110).

6.17 HYDRAULICAL TRACK MARKERS

Track markers are placed at the frame's ends and they are operated hydraulically.

To FOLD and UNFOLD the track markers, pressurize the hydraulic system.

In the case that the first track marker to be unfolded is from the non-desired side, fold it and then pressurize the system again. In this way, the track marker from the correct side will be unfolded.

Track markers can be adjusted in **LENGTH** and **DISC ORIENTATION**.



NEVER STAND UNDER THE TRACK DISCS OR WITHIN THEIR OPERATIONAL AREA..



IT IS ESSENTIAL TO FOLD THE TRACK MARKERS BEFORE FOLDING THE MACHINE FOR TRANSIT.



BEFORE FOLDING OR UNFOLDING THE TRACK MARKERS, MAKE SURE NO HIGH-VOLTAGE OVERHEAD LINES HANGING AT A LOW POSITION MAY TOUCH THEM. THIS MAY HAPPEN AS RESULT OF THE ADJUSTMENTS PERFORMED TO THEM OR DUE TO THE TERRAIN'S CONDITIONS.



WATCH OUT WHEN FOLDING THE TRACK MARKERS. DEPENDING ON THE TYPE OF PLANTER AND THE ADJUSTMENTS PERFORMED TO THE TRACK MARKER, IT MAY INTERFERE WITH THE FERTILIZER HOPPERS. IN THIS CASE, EITHER THE LENGTH OR THE DISC ORIENTATION OF THE TRACK MARKER NEEDS TO BE ADJUSTED.

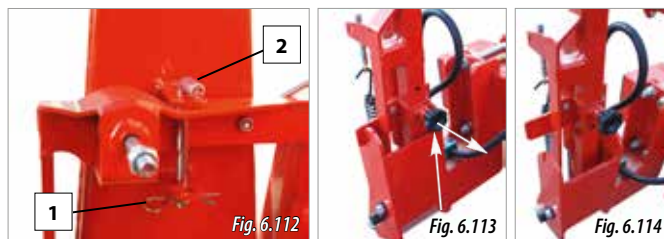

6.17.1 ADJUSTING TRACK MARKER'S LENGTH

Track marker's arms are extensible. To calculate the horizontal spacing between track discs and the last metering unit (B, Fig. 6.111), use following formula:

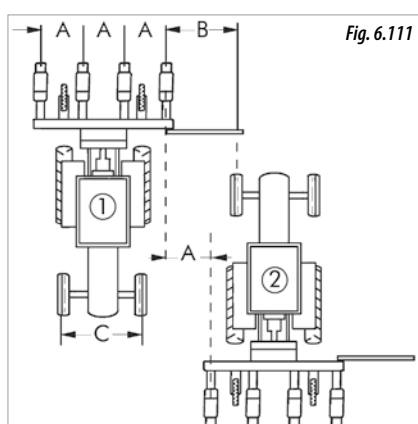

$$B = \frac{A \times (\text{number of rows} + 1) - C}{2}$$

NOTA:

A= row spacing.

B= horizontal distance between track disc and the last metering unit.

C= track width of the tractor.

This adjustment allows you to keep the same row spacing A between a length with the planter (1, Fig. 6.111) and its return (2, Fig. 6.111).

Once the distance B has been calculated, the length of the track marker's support can be adjusted:

- 1- Pressurize the track marker's hydraulic circuit to fold them so the locking handle can be removed.
- 2- Depending on the type of track marker assembled in the machine, it needs to be unlocked following these steps:
 - A. Remove the pin (1, Fig. 6.112) and the locking handle (2, Fig. 6.112).
 - B. Pull the knob and shift the locking handle upwards (Fig. 6.113) until it
- 3- Lower the track marker hydraulically.
- 4- Loosen the securing nuts (3, Fig. 6.115).
- 5- Place the track disc at the distance B previously calculated.
- 6- Retighten the securing nuts.



TRACK MARKERS CAN BE ADAPTED TO BOTH THE NARROW TUBE AND THE WIDE TUBE OF THE TELESCOPE. THE ADAPTER FOR THE TUBES (A, FIG. 6.117) HAS TO BE ASSEMBLED IN ORDER TO ADJUST THE NARROW SECTION OF THE TUBE. IT NEEDS TO BE REMOVED TO ADJUST THE WIDE SECTION OF THE TUBE.

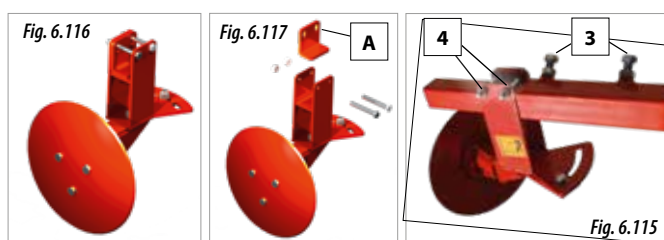

SOME PLANTERS ARE EQUIPPED WITH **TRACK MARKERS WITH TWO SECTORS TO MARK THE TRACTOR'S CENTRE**. TO ADJUST THEM AT TRACK DISTANCES **SHORTER THAN 2,25 METRES**, IT IS RECOMMENDED TO ASSEMBLE THE TRACK MARKER FROM OUTSIDE IN. (P, FIG. 6.117 BIS).

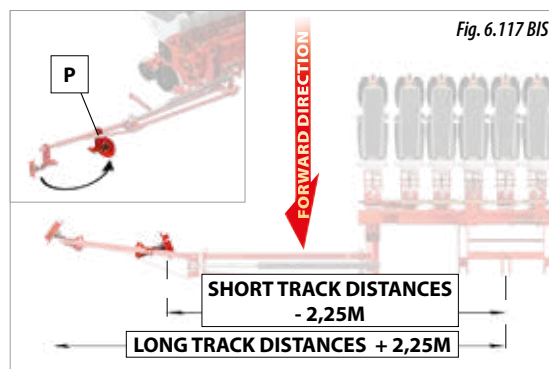

6.17.2 ADJUSTING TRACK DISC'S ORIENTATION

Adjust the track disc's orientation by loosening the securing nut (B, Fig. 6.118) so that the track disc has the desirable impact on the ground. Tighten the nut after performing this operation.



IT IS NOT RECOMMENDED TO INCLINE THE TRACK DISCS TOO MUCH, THUS PREVENTING SERIOUS DAMAGE TO THE MACHINE.

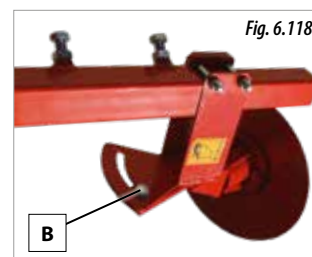

6.18 FERTILIZING EQUIPMENT (OPTIONAL)

To adjust the fertilizing equipment it is necessary to know the row spacing, the quantity of fertilizer to be spread per hectare and the fertilizer's specific weight. Take into account that there is a wide variety of fertilizers, all them having different density and granulometry, so that it is difficult to achieve a precise adjustment. To adjust the dosing, use the following tables and proceed by approximation. This table is also placed on the fertilizer hopper's cover.

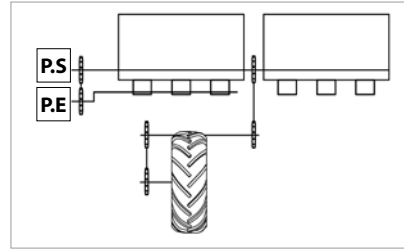

TRANSMISSION	P.S.=20Z	ROW SPACING																					
		35 cm		37,5 cm		40 cm		45 cm		50 cm		55 cm		60 cm									
	P.E.=35Z	FERTILISER'S SPECIFIC WEIGHT KG/DM ³																					
		0,8	1	1,2	0,8	1	1,2	0,8	1	1,2	0,8	1	1,2	0,8	1	1,2	0,8	1	1,2	0,8	1	1,2	
DOSING ADJUSTMENT	KG/HA																						
	6	71	89	105	66	83	98	62	78	92	55	69	82	49	62	74	45	57	67	41	51	62	
	8	89	112	135	83	105	126	78	98	118	69	87	104	62	78	94	57	71	86	52	65	78	
	10	107	135	162	100	126	151	94	118	142	84	105	126	76	94	113	68	86	103	63	79	94	
	12	126	158	190	117	147	177	110	138	166	98	123	148	89	111	133	80	100	121	74	92	111	
	14	146	181	217	137	169	203	128	158	190	113	141	169	102	127	153	93	115	138	85	106	127	
	16	165	206	247	154	192	230	144	180	216	128	159	191	115	143	172	105	131	157	96	120	143	
	18	183	229	274	171	213	256	160	200	240	142	178	213	128	160	192	116	145	175	107	133	160	
	20	201	251	302	188	235	282	176	220	264	157	196	235	141	176	211	128	160	192	117	147	176	
	22	219	274	329	205	256	307	192	240	288	171	214	257	154	193	231	140	175	209	128	160	193	
	24	238	299	359	222	279	335	208	262	314	186	232	278	167	209	251	151	191	228	139	174	209	
	26	258	322	386	241	301	361	226	282	338	200	250	300	180	225	270	164	205	246	150	188	225	
28	277	345	414	258	322	386	242	302	362	215	268	322	193	242	290	176	220	263	161	201	242		
30	295	368	441	275	343	412	258	322	386	229	287	344	206	258	310	188	234	281	172	215	258		

TRANSMISSION	P.S.=35Z	ROW SPACING																					
		35 cm		37,5 cm		40 cm		45 cm		50 cm		55 cm		60 cm									
	P.E.=20Z	FERTILISER'S SPECIFIC WEIGHT KG/DM ³																					
		0,8	1	1,2	0,8	1	1,2	0,8	1	1,2	0,8	1	1,2	0,8	1	1,2	0,8	1	1,2	0,8	1	1,2	
DOSING ADJUSTMENT	KG/HA																						
	6	137	171	206	128	160	192	120	150	180	107	134	160	96	120	144	87	109	131	80	100	120	
	8	199	247	297	186	230	277	174	216	260	154	192	231	138	173	208	127	157	189	115	144	173	
	10	258	322	386	241	301	361	226	282	338	201	251	301	181	226	271	164	205	246	151	188	226	
	12	318	398	478	297	371	446	278	348	418	248	310	372	223	279	335	202	253	304	186	232	279	
	14	379	473	569	354	442	531	332	414	498	295	369	442	265	332	398	241	301	362	221	276	332	
	16	439	549	658	410	512	614	384	480	576	342	427	513	308	385	462	279	349	419	256	321	385	
	18	501	624	750	467	582	700	438	546	656	389	486	583	350	438	525	319	397	477	292	365	438	
	20	560	702	841	523	655	785	490	614	736	436	545	654	392	490	589	356	447	535	327	409	490	
	22	622	777	933	580	725	870	544	680	816	483	604	724	435	543	652	396	495	593	362	453	543	
	24	681	853	1022	636	796	954	596	746	894	530	662	795	477	596	715	433	543	650	397	497	596	
	26	743	928	1113	693	866	1039	650	812	974	577	721	865	519	649	779	473	591	708	433	541	649	
28	802	1003	1205	749	937	1124	702	878	1054	624	780	936	562	702	842	511	639	767	468	585	702		
30	862	1079	1294	804	1007	1207	754	944	1132	671	839	1007	604	755	906	548	687	823	503	629	755		

TRANSMISSION	P.S.=20Z	ROW SPACING																		
		65 cm			70 cm			75 cm			80 cm			90 cm			95 cm			
	P.E.=35Z	FERTILISER'S SPECIFIC WEIGHT KG/DM ³																		
0,8		1	1,2	0,8	1	1,2	0,8	1	1,2	0,8	1	1,2	0,8	1	1,2	0,8	1	1,2		
DOSING ADJUSTMENT	KG/HA																			
	6	38	48	57	35	44	53	33	41	49	31	39	46	28	35	41	26	32	39	
	8	48	60	73	45	56	67	42	52	62	39	49	59	35	44	52	33	41	49	
	10	58	73	87	54	67	81	50	63	76	47	59	71	42	52	63	40	50	60	
	12	68	85	102	63	79	95	59	74	89	55	69	83	49	61	74	47	58	70	
	14	79	97	117	73	91	109	68	85	102	64	79	95	57	70	84	54	67	80	
	16	89	111	133	82	102	123	77	96	115	72	90	108	64	80	96	60	76	91	
	18	98	123	148	91	114	137	85	107	128	80	100	120	71	89	107	67	84	101	
	20	108	135	162	101	126	151	94	117	141	88	110	132	78	98	117	74	93	111	
	22	118	148	177	110	138	165	103	128	154	96	120	144	85	107	128	81	101	122	
	24	128	161	193	119	149	179	111	139	167	104	131	157	92	116	140	88	110	132	
	26	139	174	208	129	161	193	120	150	180	113	141	169	100	125	150	95	119	142	
28	149	186	223	138	173	207	129	161	193	121	151	181	108	134	161	102	127	153		
30	159	198	238	147	184	221	138	172	206	129	161	193	115	143	172	109	136	163		

TRANSMISSION	P.S.=35Z	ROW SPACING																		
		65 cm			70 cm			75 cm			80 cm			90 cm			95 cm			
	P.E.=20Z	FERTILISER'S SPECIFIC WEIGHT KG/DM ³																		
0,8		1	1,2	0,8	1	1,2	0,8	1	1,2	0,8	1	1,2	0,8	1	1,2	0,8	1	1,2		
DOSING ADJUSTMENT	KG/HA																			
	6	74	92	111	69	86	103	64	80	96	60	75	90	53	67	80	51	63	76	
	8	107	133	160	99	124	148	92	115	138	87	108	130	77	96	116	73	91	109	
	10	139	174	208	129	161	194	121	151	181	113	141	169	100	125	150	95	119	143	
	12	171	214	257	159	199	239	149	186	223	139	174	209	124	155	186	117	147	176	
	14	204	255	306	190	237	284	177	221	265	166	207	249	148	184	221	140	175	210	
	16	236	295	354	220	275	330	205	256	308	192	240	288	171	213	256	162	202	243	
	18	270	336	404	250	313	375	233	292	350	219	273	328	195	243	292	184	230	276	
	20	302	378	453	280	350	420	262	327	392	245	307	368	218	273	327	207	258	310	
	22	335	418	502	310	388	466	290	362	435	272	340	408	242	302	363	229	286	343	
	24	367	459	550	341	426	511	318	397	477	298	373	447	265	332	397	251	314	377	
	26	400	500	599	371	464	556	346	433	519	325	406	487	289	361	433	273	342	410	
28	432	540	649	401	501	602	374	468	562	351	439	527	312	390	468	296	369	443		
30	464	581	697	431	539	647	403	503	604	377	472	566	335	420	503	318	397	477		

Adjustments on fertilizer spreading are centralized in each fertilizer hopper of the planter. Fertilizer's dosing device is adjusted by turning its adjusting wheel (1, Fig. 6.119). The adjusting scale has values from 0 to 30 (2, Fig. 6.119).

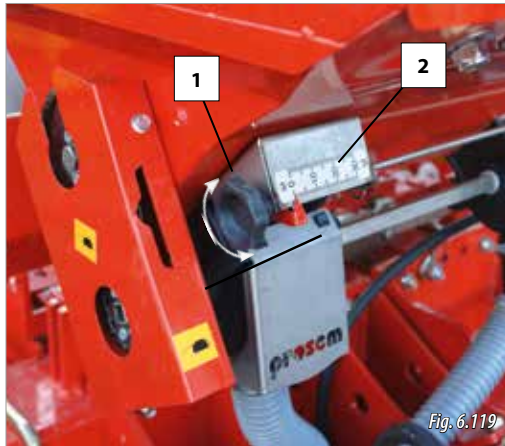

If the specific weight of the fertilizer to be used is different from the ones in the dosing tables, apply the following formula to calculate the Kg/ha which are going to be spread:

$$Z = \frac{\text{Weight}_T}{\text{Weight}_R} \times V$$

WHERE:

Z = Kg/ha which are going to be spread.

V = Kg/ha in the table depending on the dosing adjustment, the row spacing and the fertilizer's specific weight shown in the table.

Weight_T = specific weight shown in the table depending on the selected value "V"

Weight_R = actual specific weight of the fertilizer.

In case of fertilizing at a different row spacing from the ones in the dosing tables, apply the following formula:

$$Z = \frac{D_{TABLE}}{D_{DESIRED}} \times V$$

WHERE:

Z = Kg/ha which are going to be spread.

V = Kg/ha in the table depending on the dosing adjustment, the row spacing and the fertilizer's specific weight shown in the table.

D_{TABLE} = row spacing shown in the table.

D_{DESIRED} = desired row spacing.

VERY IMPORTANT: $D_{TABLE} > D_{DESIRED}$



IT IS NOT RECOMMENDED TO USE VALUES UNDER 10 IN THE ADJUSTING SCALE, SINCE THEY MAY RESULT IN IRREGULAR SPREADING DUE TO THE FERTILISER'S GRAIN GEOMETRY.



THE MACHINE COMES ASSEMBLED WITH A DISTANCE BETWEEN FERTILIZERS FROM 5 TO 9 CENTIMETRES IN RELATION TO THE PLANTING ROW. FOR NO-TILL FARMING FROM 5 TO 15 CENTIMETRES.



BEFORE START PLANTING, MAKE SURE THAT THE DISTANCES BETWEEN PLANTING ROWS AND FERTILIZER ROWS ARE CORRECT.

6.18.1 REPLACING THE FERTILIZER'S TRANSMISSION

For a wider range of adjustments, cogs A and B are interchangeable. The previous table shows both possible type of transmissions **P.S= 20Z P.E= 35Z** or **P.S=35Z P.E=20Z**.

To change the transmission ratio:

- 1- Remove the lid's securing screws (1, Fig. 6.120).

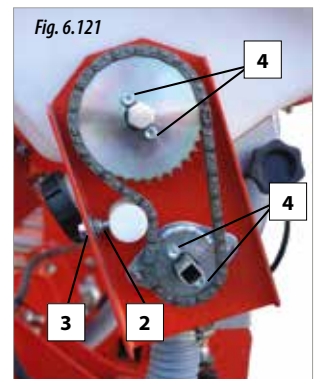
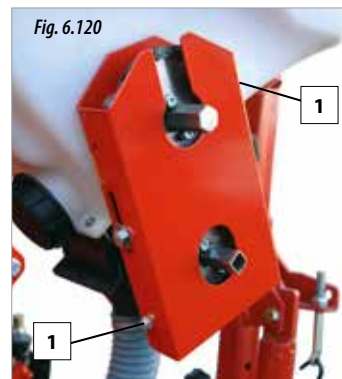

- 2- Loosen the chain. For this purpose, use a wrench to operate on the tensioner's nut (2, fig. 6.121). To make this operation easier, hold the tensioner's screw (3, Fig. 6.121) using a different wrench (Fig. 6.122).



- 3- Remove the securing allen screws from the pinions (4, Fig. 6.121).
- 4- Remove the pinions and interchange their position.
- 5- Fix the pinions using the screws (4, Fig. 6.121).
- 6- Place the tensioner at the suitable position and fix it using the nut. For this operation, hold the screw using a different wrench (Fig. 6.122).
- 7- Place the lid back and fix it using the screws (1, Fig. 6.120)

6.18.2 FERTILISER'S DOUBLE DISC

The rod has 4 possible positions placed along 6 cm (Fig. 6.123). To adjust rod's height:

ROD'S HEIGHT

The rod has 4 possible positions placed along 6 cm (Fig. 6.123). To adjust rod's height:

- 1- Remove the pin (1, Fig. 6.124)
- 2- Loosen the screw (2, Fig. 6.124)
- 3- Shift the rod to the desired position.
- 4- Place the pin in the desired hole to fix the position (1, Fig. 6.124)
- 5- Finally, lock the rod using the screw and the lock nut (2, Fig. 6.124).

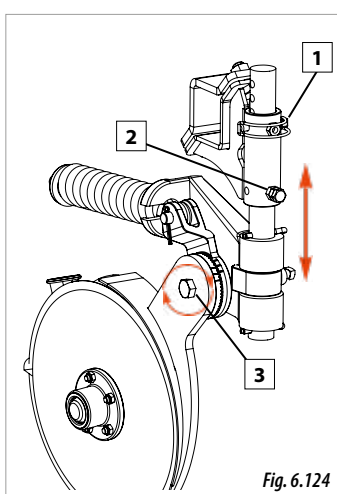
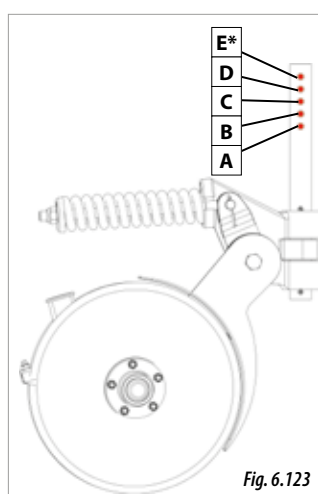

WHEN ADJUSTING THE CONNECTING ROD'S ANGLE, ADJUST THE COG'S TOOTH SPACE SO THAT THEY STAY AS ALIGNED AS POSSIBLE (Fig. 6.125).



Fig. 6.125



THE FERTILIZER'S DISCS NEED TO DIG INTO THE EARTH. ON THE OTHER HAND, THEIR SUPPORT SHOULD NOT WORK DIGGING INTO THE EARTH UNDER ANY CIRCUMSTANCES. FOR THIS PURPOSE, THE SUPPORT NEEDS TO BE ADJUSTED SO THAT IT WORKS IN A RAISED POSITION OF AT LEAST 2 CENTIMETRES (APPROXIMATELY) ABOVE THE GROUND (Fig. 6.126).

6.18.3 FERTILISER'S SHARE

To modify the share's height:

- 1- Loosen the two lock nuts and the two securing screws of the share (1, Fig. 6.127).
- 2- Hold the share to prevent it from falling and loosen the lock nut and the screw (2, Fig. 6.127).
- 3- Place the share at the desired depth.
- 4- Fix the share's position using the two screws with their lock nuts (1, Fig. 6.127), and the screw with its lock nut (2, Fig. 6.127).

ROD'S POSITION	ROD'S DEPTH (cm)
A	0
B	2
C	4
D	6
E*	8

* Not available in versions No-Till of the fertilizer's disc.

POSITION OF THE DOUBLE DISC'S CONNECTING ROD

For a more precise adjustment of the fertilizer's height, the connecting rod's angle needs to be adjusted:

- 1- Loosen the discs' fixing screw (3, Fig. 6.124)
- 2- Turn the discs until reaching the desired angle of the connecting rod.
- 3- Tighten the fixing screw (3, Fig. 6.124).

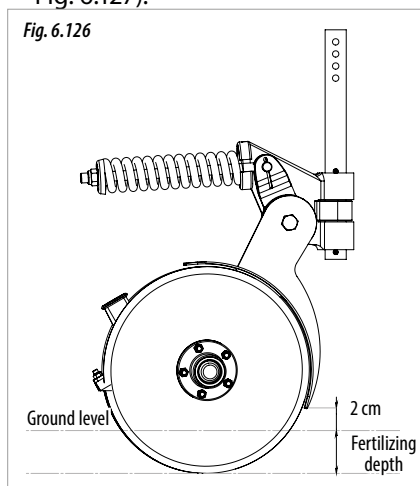

Fig. 6.126



Fig. 6.127

6.18.4 FERTILIZERS ON PLANTING ELEMENT (OPTIONAL)

- DOUBLE FERTILIZER DISC ON ELEMENT SUPPORT

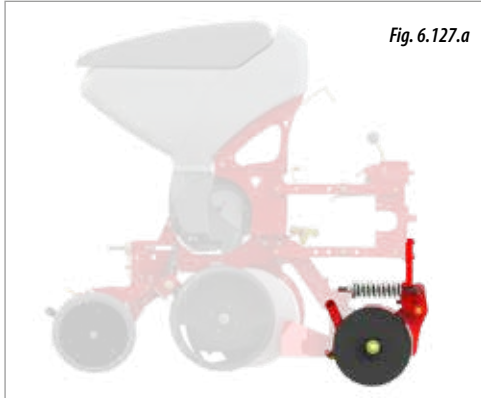

Fig. 6.127.a

- FERTILIZER COULTER ON ELEMENT SUPPORT

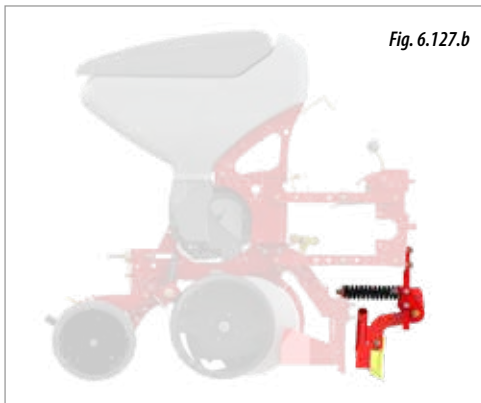

Fig. 6.127.b

To adjust position:

- HEIGHT

Operate the nuts and screws to modify the working depth (1, Fig. 6.127.c).

- PRESSURE

Operate the nut to modify the pressure of the unit (2, Fig. 6.127.c).

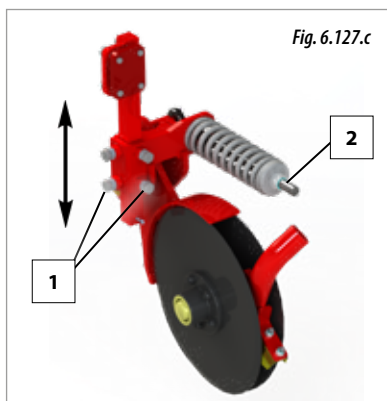

Fig. 6.127.c

6.19 MICRO GRANULAR FERTILIZER (OPTIONAL)



Fig. 6.128

In order to adjust the distribution of the micro granular fertilizer, it is necessary to know the row spacing, the quantity of product to be distributed per hectare and its specific weight.

It should be taken into account that there is a wide variety of products, each one with its particular density and granulometry. Therefore, precise adjustments are difficult to achieve.

Micro granulated fertilizer is placed along with the seeds (Fig. 6.129).

If the specific weight of the fertilizer to be used is different from the ones in the dosing tables, apply the following formula to calculate the Kg/ha which are going to be spread:

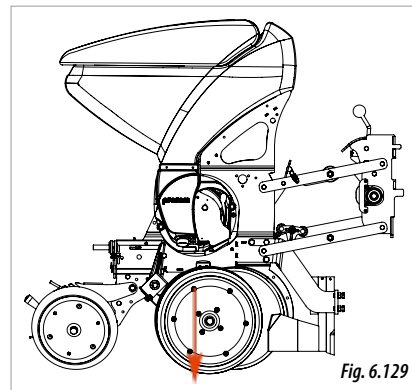

Fig. 6.129

$$Z = \frac{\text{Weight}_T}{\text{Weight}_R} \times V$$

WHERE:

Z = Kg/ha which are going to be spread.

V = Kg/ha in the table depending on the dosing adjustment, the row spacing and the fertilizer's specific weight shown in the table.

Weight_T = specific weight shown in the table depending on the selected value "V"

Weight_R = actual specific weight of the fertilizer.

In case to spread fertilizer at a different row spacing from the ones in the dosing tables, apply the following formula:

$$Z = \frac{D_{TABLE}}{D_{DESIRED}} \times V$$



TO ADJUST THE DISTRIBUTION OF FERTILIZER, PROCEED BY APPROXIMATION USING THE FOLLOWING TABLES:

WHERE:

Z = Kg/ha which are going to be spread.

V = Kg/ha in the table depending on the dosing adjustment, the row spacing and the fertilizer's specific weight shown in the table.

D_{TABLE} = row spacing shown in the table.

D_{DESIRED} = desired row spacing.

VERY IMPORTANT: D_{TABLE} > D_{DESIRED}

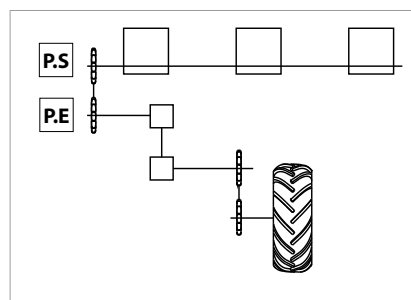

TRANSMISSION	P.S 22Z	ROW SPACING																											
		35 cm				37,5 cm				40 cm				45 cm				50 cm				55 cm				60 cm			
	P.E 12Z	SPECIFIC WEIGHT OF THE PRODUCT KG/DM ³																											
0,8		1	1,2	*1,4	0,8	1	1,2	*1,4	0,8	1	1,2	*1,4	0,8	1	1,2	*1,4	0,8	1	1,2	*1,4	0,8	1	1,2	*1,4	0,8	1	1,2	*1,4	
DOSING ADJUSTMENT	KG/HA																												
	A/6	4,2	5,4	6,4	12,7	4,0	5,0	6,0	11,9	3,7	4,7	5,6	11,1	3,3	4,2	5	9,9	3,0	3,8	4,5	8,9	2,7	3,4	4,1	8,1	2,5	3,2	3,8	7,4
	A/8	4,5	5,7	6,8	14,0	4,2	5,3	6,4	13,1	3,9	5,0	6,0	12,3	3,5	4,4	5,3	10,9	3,2	4,0	4,8	9,8	2,9	3,6	4,3	8,9	2,6	3,3	4,0	8,2
	B/0	5,5	6,8	8,2	15,4	5,2	6,4	7,7	14,4	4,8	6,0	7,2	13,5	4,3	5,3	6,4	12	3,9	4,8	5,8	10,8	3,5	4,3	5,2	9,8	3,2	4,0	4,8	9,0
	B/5	6,9	8,6	10,4	18,9	6,5	8,0	9,7	17,6	6,1	7,5	9,1	16,5	5,4	6,7	8,1	14,7	4,9	6,0	7,3	13,2	4,4	5,5	6,6	12,0	4,1	5,0	6,1	11,0
	C/0	8,6	10,8	12,9	22,2	8,0	10,1	12,0	20,8	7,5	9,5	11,3	19,5	6,7	8,4	10	17,3	6,0	7,6	9,0	15,6	5,5	6,9	8,2	14,2	5,0	6,3	7,5	13,0
	C/5	10,3	12,9	15,4	25,7	9,6	12,0	14,4	24,0	9,0	11,3	13,5	22,5	8	10	12	20	7,2	9,0	10,8	18,0	6,5	8,2	9,8	16,4	6,0	7,5	9,0	15,0
	D/0	12,0	14,9	17,9	29,2	11,2	13,9	16,7	27,2	10,5	13,1	15,6	25,5	9,3	11,6	13,9	22,7	8,4	10,4	12,5	20,4	7,6	9,5	11,4	18,6	7,0	8,7	10,4	17,0
	D/5	13,4	16,7	20,1	32,7	12,5	15,6	18,7	30,5	11,7	14,6	17,6	28,6	10,4	13	15,6	25,4	9,4	11,7	14,0	22,9	8,5	10,6	12,8	20,8	7,8	9,8	11,7	19,1
	E/0	14,8	18,5	22,2	36,0	13,8	17,3	20,8	33,6	12,9	16,2	19,5	31,5	11,5	14,4	17,3	28	10,4	13,0	15,6	25,2	9,4	11,8	14,2	22,9	8,6	10,8	13,0	21,0
E/5	15,8	19,7	23,7	39,5	14,8	18,4	22,1	36,8	13,8	17,2	20,7	34,5	12,3	15,3	18,4	30,7	11,1	13,8	16,6	27,6	10,1	12,5	15,1	25,1	9,2	11,5	13,8	23,0	

* BELEM product (density 1.4 kg/dm³)

TRANSMISSION	P.S 12Z	ROW SPACING																											
		35 cm				37,5 cm				40 cm				45 cm				50 cm				55 cm				60 cm			
	P.E 22Z	SPECIFIC WEIGHT OF THE PRODUCT KG/DM ³																											
0,8		1	1,2	*1,4	0,8	1	1,2	*1,4	0,8	1	1,2	*1,4	0,8	1	1,2	*1,4	0,8	1	1,2	*1,4	0,8	1	1,2	*1,4	0,8	1	1,2	*1,4	
DOSING ADJUSTMENT	KG/HA																												
	B/0	18,5	23	28	43	17,2	22	26	40	16,2	20	24	37	14,4	17,9	22	33	12,9	16,2	19,4	30	11,7	14,7	17,6	27	10,8	13,5	16,2	25
	B/5	23	29	35	47	22	27	33	44	20	25	31	41	18,2	23	27	37	16,3	20	25	33	14,9	18,5	22	30	13,6	16,9	20	28
	C/0	29	36	43	52	27	34	41	48	25	32	38	45	23	28	34	40	20	25	30	36	18,5	23	28	33	16,9	21	25	30
	C/5	34	43	52	62	32	40	48	58	30	38	45	55	27	34	40	49	24	30	36	44	22	27	33	40	20	25	30	36
	D/0	40	50	60	76	37	47	56	71	35	44	52	67	31	39	46	59	28	35	42	53	26	32	38	48	23	29	35	44
	D/5	45	57	68	87	42	53	63	81	39	50	59	76	35	44	53	68	32	40	48	61	29	36	43	55	26	33	40	51
	E/0	50	62	76	98	46	58	71	91	43	55	67	86	39	49	59	76	35	44	53	68	32	40	48	62	29	36	44	57
E/5	53	65	79	109	49	61	73	101	46	57	69	95	41	51	61	84	37	46	55	76	34	41	50	69	31	38	46	63	

TRANSMISSION	P.S	ROW SPACING																							
	22Z	65 cm				70 cm				75 cm				80 cm				90 cm				95 cm			
	P.E	SPECIFIC WEIGHT OF THE PRODUCT KG/DM ³																							
12Z	0,8	1	1,2	*1,4	0,8	1	1,2	*1,4	0,8	1	1,2	*1,4	0,8	1	1,2	*1,4	0,8	1	1,2	*1,4	0,8	1	1,2	*1,4	
DOSING ADJUSTMENT		KG/HA																							
	A/6	2,3	2,9	3,5	6,9	2,1	2,7	3,2	6,4	2,0	2,5	3,0	5,9	1,9	2,4	2,8	5,6	1,7	2,1	2,5	5,0	1,6	2,0	2,4	4,7
	A/8	2,4	3,0	3,7	7,5	2,3	2,8	3,4	7,0	2,1	2,6	3,2	6,5	2,0	2,5	3,0	6,1	1,8	2,2	2,7	5,5	1,7	2,1	2,5	5,2
	B/0	3,0	3,7	4,4	8,3	2,8	3,4	4,1	7,7	2,6	3,2	3,8	7,2	2,4	3,0	3,6	6,8	2,2	2,7	3,2	6,0	2,0	2,5	3,0	5,7
	B/5	3,7	4,6	5,6	10,2	3,5	4,3	5,2	9,5	3,2	4,0	4,9	8,8	3,0	3,8	4,6	8,3	2,7	3,4	4,1	7,4	2,6	3,2	3,8	7,0
	C/0	4,6	5,8	6,9	12,0	4,3	5,4	6,4	11,1	4,0	5,0	6,0	10,4	3,8	4,7	5,6	9,7	3,4	4,2	5,0	8,7	3,2	4,0	4,7	8,2
	C/5	5,5	6,9	8,3	13,8	5,1	6,4	7,7	12,9	4,8	6,0	7,2	12,0	4,5	5,6	6,8	11,3	4,0	5,0	6,0	10,0	3,8	4,7	5,7	9,5
	D/0	6,4	8,0	9,6	15,7	6,0	7,5	8,9	14,6	5,6	7,0	8,3	13,6	5,2	6,5	7,8	12,8	4,7	5,8	7,0	11,4	4,4	5,5	6,6	10,8
	D/5	7,2	9,0	10,8	17,6	6,7	8,4	10,0	16,3	6,2	7,8	9,4	15,2	5,9	7,3	8,8	14,3	5,2	6,5	7,8	12,7	4,9	6,2	7,4	12,0
	E/0	8,0	10,0	12,0	19,4	7,4	9,3	11,1	18,0	6,9	8,6	10,4	16,8	6,5	8,1	9,7	15,8	5,8	7,2	8,7	14,0	5,4	6,8	8,2	13,3
E/5	8,5	10,6	12,7	21,3	7,9	9,8	11,8	19,7	7,4	9,2	11,0	18,4	6,9	8,6	10,4	17,3	6,2	7,7	9,2	15,4	5,8	7,2	8,7	14,5	

* BELEM product (density 1.4 kg/dm³)

TRANSMISSION	P.S	ROW SPACING																							
	12Z	65 cm				70 cm				75 cm				80 cm				90 cm				95 cm			
	P.E	SPECIFIC WEIGHT OF THE PRODUCT KG/DM ³																							
22Z	0,8	1	1,2	*1,4	0,8	1	1,2	*1,4	0,8	1	1,2	*1,4	0,8	1	1,2	*1,4	0,8	1	1,2	*1,4	0,8	1	1,2	*1,4	
DOSING ADJUSTMENT		KG/HA																							
	B/0	9,9	12,4	14,9	23	9,2	11,5	13,8	21	8,6	10,8	12,9	19,9	8,1	10,1	12,1	18,6	7,2	9,0	10,8	16,6	6,8	8,5	10,2	15,7
	B/5	12,6	15,6	18,9	25	11,7	14,5	17,5	24	10,9	13,6	16,3	22	10,2	12,7	15,3	21	9,1	11,3	13,6	18,4	8,6	10,7	12,9	17,4
	C/0	15,6	19,4	23	28	14,5	18,1	22	26	13,6	16,8	20	24	12,7	15,8	19,0	23	11,3	14,0	16,9	20	10,7	13,3	16,0	19,1
	C/5	18,6	23	28	34	17,2	22	26	31	16,1	20	24	29	15,1	18,9	23	27	13,4	16,8	20	24	12,7	15,9	19,1	23
	D/0	22	27	32	41	20	25	30	38	18,7	23	28	35	17,6	22	26	33	15,6	19,5	23	30	14,8	18,5	22	28
	D/5	24	31	37	47	23	29	34	43	21	27	32	41	19,7	25	30	38	17,5	22	26	34	16,6	21	25	32
	E/0	27	34	41	53	25	31	38	49	23	29	35	46	22	27	33	43	19,3	24	30	38	18,3	23	28	36
E/5	29	35	42	58	26	33	39	54	25	30	37	51	23	29	34	48	21	25	31	42	19,5	24	29	40	

Next to each dosing device there is an adjusting wheel (A, Fig. 6.128). Turn it to adjust the fertilizer distribution.

The spindle has an adjusting scale marked from A to E, and the nut has 10 numbers for each letter. For each dosing device adjust the ratchet's letter to the nut's number (A, Fig. 6.128).



IT IS NOT RECOMMENDED USE POSITIONS LOWER THAN B/0 SINCE THEY MAY RESULT IN AN IRREGULAR DISTRIBUTION.

To empty the fertilizer or micro granular pesticide's hoppers, see section 8.3 INSECTISIDE MICROGRANULATOR'S AND/OR MICRO GRANULAR PESTICIDE'S HOPPERS.

The micro granular fertilizer is equipped with a double cog that allows to change the transmission of the dosing device. In this way, there is a wider range of possible dosages. Previous table shows both possible transmissions **P.S=12Z P.E=22Z** or **P.S=22Z P.E=12Z**.

6.19.1 CHANGING THE MICRO GRANULATOR'S TRANSMISSION

To change the micro granulator's transmission, proceed as follows:

- 1- Remove the wing nut and the upper screw of the drive's lid (Fig. 6.130).
- 2- Turn the lid downwards.
- 3- Using two wrenches, loosen the tensioners (Fig. 6.131).
- 4- Push the tensioner downwards to loosen the chain.
- 5- Change the chain's position (Fig. 6.132).
- 6- Tighten the chain using the 2 tensioners.
- 7- Lock the tensioner's position using the securing nuts.
- 8- Finally, close the lid and fix it using the screw and the wing nut.

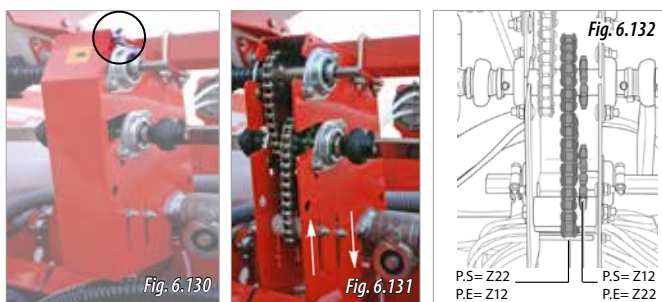

6.19.2 EXCLUDING THE MICRO GRANULATOR

To disconnect the transmission of the micro granulator hoppers, it is necessary to operate on the transmission's box of the micro granulator hoppers (see section 3.1 PLANTER OVERVIEW). There are three types of gearboxes, all of them have the clutch on one of the axles (shown in red, Fig. 6.133).

Disconnect the transmission when fertilizing the field is not required.

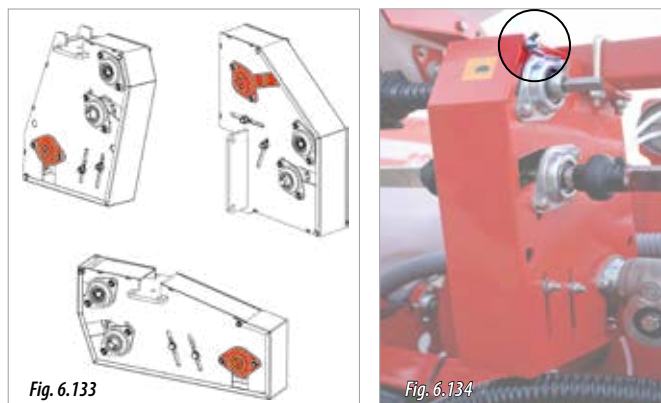

To exclude the transmission, follow these steps:

- 1- Remove the wing nut and the upper screw of the drive's lid (Fig. 6.134).
- 2- Turn the lid downwards.
- 3- In the transmission axle where the clutch is (Fig. 6.133), pull the securing knob and turn it 90° to lock it at the free transmission position (Fig. 6.135).
- 4- Close the lid and fix it using the screw and the wing nut.

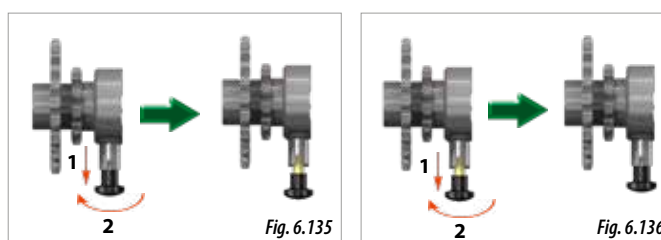

To reconnect the transmission:

- 1- Remove the wing nut and the upper screw of the drive's lid (Fig. 6.134).
- 2- Turn the lid downwards.
- 3- On the transmission axle where the clutch is (Fig. 6.133), pull the securing knob and turn it 90° to lock it at the transmission position (Fig. 6.136).
- 4- Close the lid and fix it using the screw and the wing nut.

6.20 MICRO GRANULAR PESTICIDE (OPTIONAL)



In order to adjust the distribution of the micro granular pesticide, it is necessary to know the row spacing, the quantity of product to be distributed per hectare and its specific weight. It should be taken into account that there is a wide variety of products, each one with its particular density and granulometry. Therefore, precise adjustments are difficult to achieve. Micro granulated pesticide can be placed in two ways, as required:

- **SEMI-SUPERFICIAL** (1, Fig. 6.138).
- **SUPERFICIAL** (2, Fig. 6.138).

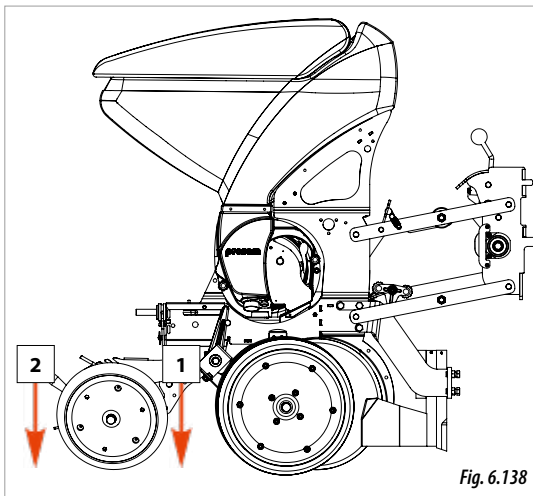

If the specific weight of the pesticide to be used is different from the ones in the dosing tables, apply the following formula to calculate the Kg/ha which are going to be spread:

$$Z = \frac{\text{Weight}_T}{\text{Weight}_R} \times V$$

WHERE:

Z = Kg/ha which are going to be spread.

V = Kg/ha in the table depending on the dosing adjustment, the row spacing and the pesticide's specific weight shown in the table.

Weight_T = specific weight shown in the table depending on the selected value "V".

Weight_R = actual specific weight of the pesticide.

In case to spread pesticide at a different row spacing from the ones in the dosing tables, apply the following formula:

$$Z = \frac{D_{TABLE}}{D_{DESIRED}} \times V$$

WHERE:

Z = Kg/ha which are going to be spread.

V = Kg/ha in the table depending on the dosing adjustment, the row spacing and the pesticide's specific weight shown in the table.

D_{TABLE} = row spacing shown in the table.

D_{DESIRED} = desired row spacing.

VERY IMPORTANT: $D_{TABLE} > D_{DESIRED}$

Next to each dosing device, there is an adjusting wheel (A, Fig. 6.137). Turn it to adjust the pesticide distribution.

The ratchet has a adjusting scale marked from A to E, and the nut has 10 numbers for each letter. For each dosing device adjust the ratchet's letter to the nut's number (A, Fig. 6.137).



IT IS NOT RECOMMENDED USE POSITIONS LOWER THAN B/0 SINCE THEY MAY RESULT IN AN IRREGULAR DISTRIBUTION.

To empty the hoppers of the micro granular fertilizer and the micro granular pesticide, see sections 8.3 INSECTISIDE MICRO GRANULATOR'S AND/OR MICRO GRANULAR PESTICIDE'S HOPPERS.

Also, the machine is equipped with a double cog that allows you to make a change the metering box's transmission. In this way, there is a wider range of possible dosages. Previous table shows both possible transmissions **P.S=12Z P.E=22Z** or **P.S=22Z P.E=12Z**.

In order to change the transmission ratio or exclude it, see section 6.19.1 CHANGING THE MICROGRANULATOR'S TRANSMISSION and/or 6.19.2 EXCLUDING THE MICROGRANULATOR.



TO ADJUST THE DISTRIBUTION OF PESTICIDE, PROCEED BY APPROXIMATION USING THE FOLLOWING TABLES:

TRANSMISSION	P.S=22Z	ROW SPACING																										
		35 cm				37,5 cm				40 cm				45 cm				50 cm				55 cm				60 cm		
	P.E=12Z	SPECIFIC WEIGHT OF THE PRODUCT KG/DM ³																										
0,8		1	1,2	0,8	1	1,2	0,8	1	1,2	0,8	1	1,2	0,8	1	1,2	0,8	1	1,2	0,8	1	1,2							
DOSING ADJUSTMENT	KG/HA																											
	A/6	5,5	6,9	8,2	5,1	6,4	7,7	4,8	6,0	7,2	4,3	5,4	6,4	3,9	4,8	5,8	3,5	4,4	5,2	3,2	4,0	4,8						
	A/8	5,7	7,3	8,7	5,3	6,8	8,1	5,0	6,4	7,6	4,5	5,7	6,8	4,1	5,1	6,1	3,6	4,7	5,5	3,4	4,2	5,1						
	B/0	7,1	8,9	10,5	6,6	8,3	9,8	6,2	7,8	9,2	5,5	6,9	8,2	4,9	6,2	7,4	4,5	5,7	6,7	4,1	5,1	6,2						
	B/5	8,9	11,2	13,3	8,3	10,5	12,4	7,8	9,8	11,6	6,9	8,6	10,4	6,2	7,8	9,3	5,7	7,1	8,4	5,2	6,5	7,8						
	C/0	11,0	13,7	16,5	10,2	12,8	15,4	9,6	12,0	14,4	8,6	10,7	12,9	7,7	9,7	11,6	7,0	8,7	10,5	6,4	8,1	9,7						
	C/5	13,3	16,5	19,9	12,4	15,4	18,6	11,6	14,4	17,4	10,3	12,8	15,4	9,2	11,5	13,8	8,4	10,5	12,7	7,7	9,6	11,5						
	D/0	15,3	19,2	23,1	14,3	17,9	21,5	13,4	16,8	20,2	11,9	14,9	17,9	10,7	13,4	16,1	9,7	12,2	14,7	8,9	11,2	13,4						
	D/5	17,1	21,5	25,8	16,0	20,1	24,1	15,0	18,8	22,6	13,4	16,7	20,0	12,0	15,0	18,0	10,9	13,7	16,4	10,0	12,5	15,0						
	E/0	19,0	23,8	28,6	17,7	22,2	26,7	16,6	20,8	25,0	14,8	18,5	22,2	13,3	16,6	20,0	12,1	15,1	18,2	11,1	13,9	16,6						
E/5	20,3	25,4	30,4	19,0	23,7	28,4	17,8	22,2	26,6	15,7	19,7	23,6	14,2	17,7	21,3	12,9	16,1	19,3	11,8	14,8	17,7							

TRANSMISSION	P.S=12Z	ROW SPACING																										
		35 cm				37,5 cm				40 cm				45 cm				50 cm				55 cm				60 cm		
	P.E=22Z	SPECIFIC WEIGHT OF THE PRODUCT KG/DM ³																										
0,8		1	1,2	0,8	1	1,2	0,8	1	1,2	0,8	1	1,2	0,8	1	1,2	0,8	1	1,2	0,8	1	1,2							
DOSING ADJUSTMENT	KG/HA																											
	B/0	14,4	18,1	21,5	13,4	16,9	20,1	12,6	15,8	18,8	11,2	14,0	16,8	10,1	12,6	15,1	9,2	11,5	13,7	8,4	10,5	12,6						
	B/5	18,1	22,6	27,2	16,9	21,1	25,4	15,8	19,8	23,8	14,1	17,6	21,2	12,7	15,9	19,1	11,5	14,4	17,3	10,6	13,2	15,9						
	C/0	22,6	28,1	33,8	21,1	26,2	31,6	19,8	24,6	29,6	17,5	21,9	26,3	15,8	19,7	23,7	14,4	17,9	21,5	13,1	16,4	19,7						
	C/5	27,0	33,6	40,5	25,2	31,4	37,8	23,6	29,4	35,4	20,9	26,2	31,4	18,8	23,6	28,3	17,2	21,4	25,7	15,7	19,6	23,6						
	D/0	31,3	39,1	46,9	29,2	36,5	43,7	27,4	34,2	41,0	24,3	30,4	36,5	21,9	27,4	32,9	19,9	24,9	29,8	18,3	22,8	27,4						
	D/5	35,0	43,9	52,6	32,6	41,0	49,1	30,6	38,4	46,0	27,3	34,1	40,9	24,5	30,7	36,8	22,3	27,9	33,5	20,4	25,6	30,7						
	E/0	38,9	48,5	58,3	36,3	45,2	54,4	34,0	42,4	51,0	30,2	37,7	45,3	27,2	34,0	40,8	24,7	30,8	37,1	22,6	28,3	34,0						
E/5	41,4	51,7	61,9	38,6	48,2	57,8	36,2	45,2	54,2	32,1	40,2	48,2	28,9	36,2	43,4	26,3	32,9	39,4	24,1	30,1	36,2							

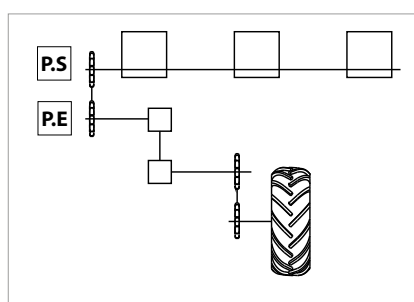

TRANSMISSION	P.S=22Z	ROW SPACING																	
		65 cm			70 cm			75 cm			80 cm			90 cm			95 cm		
	P.E=12Z	SPECIFIC WEIGHT OF THE PRODUCT KG/DM ³																	
		0,8	1	1,2	0,8	1	1,2	0,8	1	1,2	0,8	1	1,2	0,8	1	1,2	0,8	1	1,2
DOSING ADJUSTMENT		KG/HA																	
	A/6	3,0	3,7	4,4	2,8	3,5	4,1	2,6	3,2	3,9	2,4	3,0	3,6	2,1	2,7	3,2	2,0	2,5	3,1
	A/8	3,1	3,9	4,7	2,9	3,6	4,4	2,7	3,4	4,1	2,5	3,2	3,8	2,2	2,8	3,4	2,1	2,7	3,2
	B/0	3,8	4,8	5,7	3,5	4,4	5,3	3,3	4,1	4,9	3,1	3,9	4,6	2,8	3,5	4,1	2,6	3,2	3,9
	B/5	4,8	6,0	7,1	4,4	5,6	6,7	4,2	5,2	6,2	3,9	4,9	5,8	3,5	4,4	5,2	3,3	4,1	4,9
	C/0	5,9	7,4	8,9	5,5	6,9	8,3	5,2	6,4	7,7	4,8	6,0	7,2	4,3	5,3	6,4	4,1	5,1	6,1
	C/5	7,1	8,9	10,7	6,6	8,2	9,9	6,2	7,7	9,2	5,8	7,2	8,7	5,2	6,4	7,7	4,9	6,1	7,3
	D/0	8,2	10,3	12,4	7,7	9,6	11,5	7,2	8,9	10,7	6,7	8,4	10,1	6,0	7,5	9,0	5,7	7,1	8,5
	D/5	9,2	11,6	13,9	8,6	10,7	12,9	8,0	10,0	12,0	7,5	9,4	11,3	6,7	8,4	10,0	6,3	7,9	9,5
	E/0	10,2	12,8	15,4	9,5	11,9	14,3	8,9	11,1	13,3	8,3	10,4	12,5	7,4	9,2	11,1	7,0	8,8	10,5
E/5	11,0	13,7	16,4	10,1	12,7	15,2	9,4	11,8	14,2	8,9	11,1	13,3	7,9	9,9	11,8	7,5	9,3	11,2	

TRANSMISSION	P.S=12Z	ROW SPACING																	
		65 cm			70 cm			75 cm			80 cm			90 cm			95 cm		
	P.E=22Z	SPECIFIC WEIGHT OF THE PRODUCT KG/DM ³																	
		0,8	1	1,2	0,8	1	1,2	0,8	1	1,2	0,8	1	1,2	0,8	1	1,2	0,8	1	1,2
DOSING ADJUSTMENT		KG/HA																	
	B/0	7,8	9,7	11,6	7,2	9,0	10,8	6,7	8,4	10,1	6,3	7,9	9,4	5,6	7,0	8,4	5,3	6,6	8,0
	B/5	9,7	12,2	14,6	9,1	11,3	13,6	8,5	10,6	12,7	7,9	9,9	11,9	7,0	8,8	10,6	6,7	8,4	10,0
	C/0	12,2	15,1	18,2	11,3	14,1	16,9	10,5	13,1	15,8	9,9	12,3	14,8	8,8	10,9	13,2	8,3	10,4	12,5
	C/5	14,5	18,1	21,8	13,5	16,8	20,2	12,6	15,7	18,8	11,8	14,7	17,7	10,5	13,1	15,7	9,9	12,4	14,9
	D/0	16,9	21,0	25,2	15,6	19,6	23,5	14,6	18,3	21,9	13,7	17,1	20,5	12,2	15,2	18,2	11,5	14,4	17,3
	D/5	18,8	23,6	28,3	17,5	21,9	26,3	16,4	20,4	24,5	15,3	19,2	23,0	13,6	17,1	20,4	12,9	16,1	19,4
	E/0	20,9	26,1	31,4	19,4	24,3	29,1	18,1	22,6	27,2	17,0	21,2	25,5	15,1	18,8	22,7	14,3	17,9	21,4
E/5	22,3	27,8	33,4	20,7	25,8	31,0	19,3	24,1	28,9	18,1	22,6	27,1	16,1	20,1	24,1	15,2	19,0	22,8	

6.21 MICRO GRANULAR FERTILIZER AND MICRO GRANULAR PESTICIDE (OPTIONAL)



MICRO GRANULAR FERTILIZER'S TRANSMISSION	
Pinion P.E.1	Pinion P.S.1
12	22
22	12

MICRO GRANULAR PESTICIDE'S TRANSMISSION			
Pinion P.E.1	Pinion P.S.1	Pinion P.E.2	Pinion P.S.2
12	22	12	30
12	22	22	22
22	12	12	30
22	12	22	22

In order to adjust the distribution of the micro granular fertilizer and the micro granular pesticide, it is necessary to know the row spacing, the quantity of product to be distributed per hectare and its specific weight.

It should be taken into account that there is a wide variety of products, each one with its particular density and granulometry. Therefore, precise adjustments are difficult to achieve.

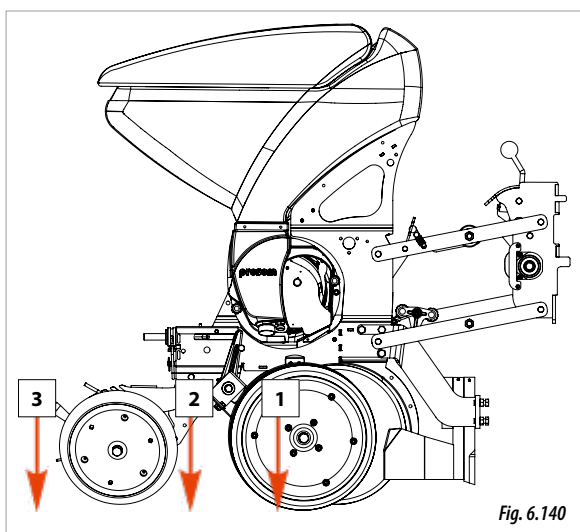

MICRO GRANULAR FERTILIZER is placed along with the seeds (1, Fig. 6.140).

MICRO GRANULAR PESTICIDE can be placed in two ways, as required:

- SEMI-SUPERFICIAL (2, Fig. 6.140).
- SUPERFICIAL (3, Fig. 6.140).

The MICRO GRANULAR FERTILIZER is equipped with a DOUBLE COG, and the HELICIEDE MICRO GRANULATOR is equipped with TWO DOUBLE COG WHEELS (both equipments have one transmission in common). These cogs allow to change the distribution so to provide a much wider range of possible dosages. The next table shows all possible combinations for the transmission:



TO CHANGE THE TRANSMISSIONS, SEE SECTIONS 6.21.1 CHANGING THE TRANSMISSION OF THE MICRO GRANULAR FERTILIZER WITH DOUBLE HOPPER AND 6.21.2 CHANGING THE TRANSMISSION OF THE MICRO GRANULAR PESTICIDE WITH DOUBLE HOPPER.



TO ADJUST THE DOSAGE OF THE **MICRO GRANULAR PESTICIDE**, PROCEED BY APPROXIMATION USING THE FOLLOWING TABLES:



IN CASE THAT EITHER THE PRODUCT'S SPECIFIC WEIGHT OR THE DESIRED ROW SPACING ARE DIFFERENT FROM THE ONES IN THE TABLES, IT IS RECOMMENDED TO CALCULATE THE KG/HA WHICH ARE GOING TO BE DISTRIBUTED BY THE MACHINE. FOR THIS PURPOSE, SEE SECTION 6.19 MICRO GRANULAR FERTILIZER OR 6.20 MICRO GRANULAR PESTICIDE.

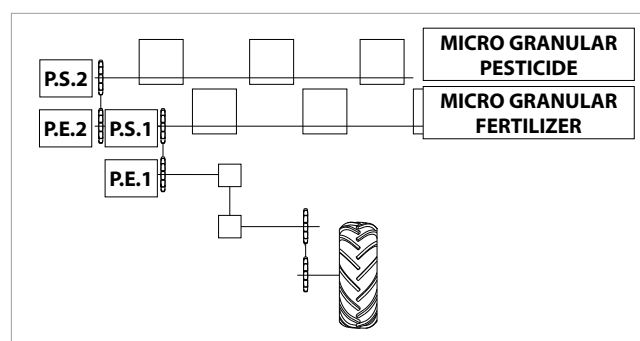

* BELEM product (density 1.4 kg/dm³)

MICRO GRANULAR FERTILIZER

ROW SPACING

TRANSMISSION		35 cm	37,5 cm	40 cm	45 cm	50 cm	55 cm	60 cm	65 cm	70 cm	75 cm	80 cm	90 cm	95 cm																																							
P.S.1		SPECIFIC WEIGHT OF THE PRODUCT KG/DW ³																																																			
12Z		KG/HA																																																			
DOSING ADJUSTMENT	A/6	4.3	5.5	6.4	12.6	4.1	5.1	6.0	11.7	3.8	4.8	5.6	11.0	3.3	4.2	5.0	9.9	3.0	3.8	4.5	8.9	2.8	3.5	4.1	8.0	2.5	3.1	3.8	7.4	2.3	3.0	3.4	6.8	2.2	2.7	3.2	6.3	2.0	2.5	3.0	5.9	1.9	2.4	2.8	5.5	1.7	2.1	2.5	4.9	1.6	2.0	2.4	4.7
	A/8	4.6	5.7	6.9	13.9	4.3	5.3	6.4	13.0	4.0	5.0	6.0	12.2	3.5	4.4	5.3	10.9	3.2	4.0	4.8	9.8	2.9	3.6	4.4	8.9	2.6	3.3	4.0	8.2	2.5	3.1	3.7	7.5	2.3	2.8	3.4	7.0	2.1	2.6	3.2	6.6	2.0	2.5	3.0	6.1	1.8	2.2	2.7	5.4	1.7	2.1	2.5	5.2
	B/0	5.5	6.9	8.2	15.5	5.1	6.4	7.7	14.5	4.8	6.0	7.2	13.6	4.3	5.3	6.4	12.0	3.8	4.8	5.8	10.8	3.5	4.4	5.2	9.9	3.2	4.0	4.8	9.0	3.0	3.7	4.4	8.4	2.7	3.4	4.1	7.7	2.6	3.2	3.8	7.2	2.4	3.0	3.6	6.8	2.1	2.7	3.2	6.0	2.0	2.5	3.0	5.7
	B/5	6.9	8.7	10.3	19.0	6.4	8.1	9.6	17.7	6.0	7.6	9.0	16.6	5.4	6.7	8.1	14.7	4.9	6.1	7.3	13.2	4.4	5.5	6.5	12.1	4.0	5.1	6.1	11.0	3.7	4.7	5.5	10.2	3.5	4.3	5.2	9.4	3.2	4.0	4.9	8.8	3.0	3.8	4.5	8.3	2.7	3.4	4.0	7.4	2.6	3.2	3.8	7.0
	C/0	8.7	10.7	12.8	22.4	8.1	10.0	11.9	20.9	7.6	9.4	11.2	19.6	6.7	8.4	10.0	17.3	6.0	7.5	9.0	15.6	5.5	6.8	8.1	14.3	5.0	6.3	7.5	13.0	4.7	5.8	6.9	12.1	4.3	5.4	6.5	11.2	4.0	5.0	6.0	10.4	3.8	4.7	5.6	9.8	3.4	4.2	5.0	8.7	3.2	4.0	4.8	8.2
	C/5	10.3	12.8	15.3	25.8	9.6	11.9	14.3	24.1	9.0	11.2	13.4	22.6	8.0	10.0	12.0	20.0	7.2	9.0	10.8	18.0	6.5	8.1	9.7	16.4	6.0	7.5	9.0	15.0	5.5	6.9	8.2	13.9	5.1	6.4	7.7	12.9	4.8	6.0	7.2	12.0	4.5	5.6	6.7	11.3	4.0	5.0	6.0	10.0	3.8	4.7	5.7	9.5
	D/0	11.9	14.9	17.8	29.3	11.1	13.9	16.6	27.3	10.4	13.0	15.6	25.6	9.3	11.6	13.9	22.7	8.4	10.5	12.5	20.4	7.6	9.5	11.3	18.6	7.0	8.7	10.5	17.0	6.4	8.0	9.6	15.8	6.0	7.5	9.0	14.6	5.6	7.0	8.4	13.6	5.2	6.5	7.8	12.8	4.6	5.8	6.9	11.4	4.4	5.5	6.6	10.7
	D/5	13.5	16.7	20.1	32.7	12.6	15.6	18.8	30.5	11.8	14.6	17.6	28.6	10.4	13.0	15.6	25.4	9.4	11.7	14.1	22.8	8.6	10.6	12.8	20.8	7.8	9.8	11.7	19.0	7.3	9.0	10.8	17.6	6.7	8.4	10.0	16.3	6.2	7.8	9.4	15.2	5.9	7.3	8.8	14.3	5.2	6.5	7.8	12.7	4.9	6.2	7.4	12.0
	E/0	14.9	18.5	22.2	36.1	13.9	17.3	20.7	33.7	13.0	16.2	19.4	31.6	11.5	14.4	17.3	28.0	10.4	13.0	15.6	25.2	9.5	11.8	14.1	23.0	8.6	10.8	13.0	21.0	8.0	10.0	11.9	19.4	7.4	9.3	11.1	18.0	6.9	8.6	10.4	16.8	6.5	8.1	9.7	15.8	5.8	7.2	8.6	14.0	5.5	6.8	8.2	13.3
	E/5	15.8	19.7	23.8	39.5	14.7	18.3	22.2	36.9	13.8	17.2	20.8	34.6	12.3	15.3	18.4	30.7	11.0	13.8	16.6	27.6	10.0	12.5	15.1	25.2	9.2	11.5	13.8	23.0	8.5	10.6	12.8	21.3	7.9	9.9	11.8	19.7	7.4	9.2	11.0	18.4	6.9	8.6	10.4	17.3	6.1	7.6	9.2	15.4	5.8	7.3	8.7	14.5

MICRO GRANULAR FERTILIZER

ROW SPACING

TRANSMISSION		35 cm	37,5 cm	40 cm	45 cm	50 cm	55 cm	60 cm	65 cm	70 cm	75 cm	80 cm	90 cm	95 cm																																							
P.S.1		SPECIFIC WEIGHT OF THE PRODUCT KG/DW ³																																																			
12Z		KG/HA																																																			
DOSING ADJUSTMENT	B/0	18.5	23.1	27.7	42.5	17.3	21.5	25.8	39.7	16.2	20.2	24.2	37.2	14.4	18.0	17.2	33	12.9	16.2	19.4	30	11.8	14.7	17.6	27.1	10.8	13.5	16.2	25	10.0	12.4	14.9	22.9	9.2	11.5	13.9	21	8.6	10.8	12.9	19.9	8.1	10.1	12.1	18.6	7.2	9.0	10.8	16.5	6.8	8.5	10.2	15.7
	B/5	23.3	29.0	35.0	48.0	21.8	27.1	32.6	44.8	20.4	25.4	30.6	42.0	18.1	23	22	37	16.3	20	24	33	14.8	18.5	22.3	30.5	13.6	17.0	20	28	12.6	15.6	18.8	25.8	11.6	14.6	17.5	24	10.9	13.6	16.3	22	10.2	12.7	15.3	21	9.1	11.3	13.6	18.7	8.6	10.7	12.9	17.4
	C/0	29.0	36.1	43.4	52.6	27.1	33.7	40.5	49.1	25.4	31.6	38.0	46.0	22	28	27	40	20	25	30	36	18.5	23.0	27.6	33.5	16.9	21	25	30	15.6	19.4	23.4	28.3	14.5	18.1	22	26	13.5	16.9	20	24	12.7	15.8	19.0	23	11.3	14.0	16.9	20.4	10.7	13.3	16.0	19.1
	C/5	34.5	43.2	52.6	64.0	32.2	40.3	49.1	59.7	30.2	37.8	46.0	56.0	27	34	32	49	24	30	36	44	22.0	27.5	33.5	40.7	20	25	30	37	18.6	23.3	28.3	34.5	17.3	22	26	32	16.1	20	24	30	15.1	18.9	23	28	13.4	16.8	20.4	24.9	12.7	15.9	19.1	23
	D/0	40.2	50.3	59.4	75.4	37.5	46.9	55.5	70.4	35.2	44.0	52.0	66.0	31	39	37	58	28	35	42	52	25.6	32.0	37.8	48.0	23	29	35	44	21.7	27.1	32.0	40.6	20	25	30	37	18.7	23	28	35	15.6	19.6	23.1	29.3	14.8	18.5	22	28				
	D/5	45.0	57.1	68.6	86.9	42.0	53.3	64.0	81.1	39.4	50.0	60.0	76.0	35	44	42	67	31	39	47	61	28.7	36.4	43.6	55.3	26	33	39	50	24.2	30.8	36.9	46.8	22	28	34	43	21	26	31	40	19.7	25	30	38	17.5	22.2	26.7	33.8	16.6	21	25	32
	E/0	50.3	61.7	75.4	98.3	46.9	57.6	70.4	91.7	44.0	54.0	66.0	86.0	39	48	46	76	35	44	52	69	32.0	39.3	48.0	62.5	29	36	44	57	27.1	33.2	40.6	52.9	25	31	37	49	23	29	35	46	22	27	33	43	19.6	24.0	29.3	38.2	18.3	23	28	36
	E/5	52.6	66.3	80.0	110	49.1	61.9	74.7	102	46.0	58.0	70.0	96.0	41	52	49	85	37	46	56	77	33.5	42.2	50.9	69.8	31	39	46	64	28.3	35.7	43.1	59.1	27	33	40	55	25	31	37	51	23	29	35	48	20.4	25.8	31.1	42.7	19.5	24	29	40

MICRO GRANULAR PESTICIDE

TRANSMISSION															
ROW SPACING															
PE.1 2/2	35 cm	37.5 cm	40 cm	45 cm	50 cm	55 cm	60 cm	65 cm	70 cm	75 cm	80 cm	90 cm	95 cm		
PE.1 1/2	0.8	1	1.2	0.8	1	1.2	0.8	1	1.2	0.8	1	1.2	0.8	1	1.2

SPECIFIC WEIGHT OF THE PRODUCT KG/DW³

DOSING ADJUSTMENT																																															
KG/HA																																															
B/0	B/5	C/0	C/5	D/0	D/5	E/0	E/5	B/0	B/5	C/0	C/5	D/0	D/5	E/0	E/5																																
9.5	12.0	14.1	8.9	11.2	13.2	8.3	10.5	12.4	7.4	9.3	11.0	6.6	8.3	9.9	6.1	7.7	9.0	5.5	6.9	8.3	5.1	6.5	7.7	4.7	5.9	7.1	4.4	5.5	6.6	4.2	5.2	6.2	3.8	4.7	5.5	4.3	5.2										
12.0	15.1	17.9	11.2	14.1	16.7	10.5	13.2	15.6	9.3	11.6	14.0	8.3	10.5	12.5	7.7	9.5	11.3	7.0	8.7	10.5	6.5	8.1	9.5	5.9	7.5	9.0	5.6	7.0	8.3	5.2	6.6	7.8	4.7	5.9	7.0	4.4	5.5	6.6									
14.8	18.4	22.2	13.7	17.2	20.7	12.9	16.1	19.4	11.6	14.4	17.3	10.4	13.0	15.6	9.4	11.7	14.1	8.6	10.9	13.0	7.9	9.9	12.0	7.4	9.3	11.2	7.0	8.6	10.4	6.5	8.1	9.7	5.8	7.1	8.6	5.5	6.9	8.2									
17.9	22.2	26.8	16.7	20.7	25.0	15.6	19.4	23.4	13.8	17.2	20.7	12.4	15.5	18.6	11.3	14.1	17.1	10.4	12.9	15.5	9.5	12.0	14.4	8.9	11.0	13.3	8.3	10.4	12.4	7.8	9.7	11.7	7.0	8.6	10.4	6.6	8.2	9.8									
20.6	25.8	31.1	19.2	24.1	28.9	18.0	22.6	27.2	16.0	20.0	24.1	14.4	18.0	21.6	13.0	16.4	19.8	12.0	15.1	18.0	11.0	13.8	16.7	10.4	12.9	15.5	10.4	12.9	15.5	9.7	12.0	14.4	8.9	11.0	13.3	8.3	10.4	12.4	7.8	9.7	11.7	7.0	8.6	10.4	6.6	8.2	9.8
23.0	28.9	34.7	21.5	27.0	32.4	20.2	25.3	30.4	18.0	22.5	26.9	16.1	20.2	24.2	14.7	18.4	22.0	13.4	16.8	20.2	12.4	15.6	18.7	11.6	14.4	17.3	10.8	13.4	16.1	10.1	12.6	15.2	9.0	11.3	13.4	8.5	10.6	12.8									
25.5	32.0	38.5	23.8	29.8	35.9	22.3	28.0	33.6	19.9	24.9	29.8	17.9	22.3	26.9	16.3	20.3	24.5	14.9	18.7	22.3	13.7	17.2	20.7	12.8	16.0	19.2	12.0	14.9	17.9	11.2	14.0	16.8	9.9	12.4	14.9	9.4	11.8	14.1									
27.3	34.1	40.9	25.5	31.9	38.2	23.9	29.8	35.8	21.1	26.5	31.7	19.1	23.8	28.6	17.3	21.6	25.9	15.9	19.9	23.8	14.8	18.4	22.0	13.6	17.1	20.4	12.6	15.9	19.1	12.0	14.9	17.9	10.6	13.3	15.9	10.1	12.5	15.1									

MICRO GRANULAR PESTICIDE

TRANSMISSION															
ROW SPACING															
PE.1 1/2	35 cm	37.5 cm	40 cm	45 cm	50 cm	55 cm	60 cm	65 cm	70 cm	75 cm	80 cm	90 cm	95 cm		
PE.1 2/2	0.8	1	1.2	0.8	1	1.2	0.8	1	1.2	0.8	1	1.2	0.8	1	1.2

SPECIFIC WEIGHT OF THE PRODUCT KG/DW³

DOSING ADJUSTMENT																																							
KG/HA																																							
A/6	A/8	B/0	B/5	C/0	C/5	D/0	D/5	E/0	E/5	A/6	A/8	B/0	B/5	C/0	C/5	D/0	D/5	E/0	E/5																				
2.2	2.8	3.3	2.0	2.6	3.1	1.9	2.4	2.9	1.7	2.2	2.6	1.6	1.9	2.3	1.4	1.8	2.1	1.3	1.6	1.9	1.2	1.5	1.8	1.1	1.4	1.6	1.0	1.3	1.6	1.0	1.2	1.4	0.8	1.1	1.3	0.8	1.0	1.2	
2.3	2.9	3.5	2.1	2.7	3.2	2.0	2.6	3.0	1.8	2.3	2.7	1.6	2.0	2.4	1.4	1.9	2.2	1.4	1.7	2.0	1.2	1.6	1.9	1.2	1.4	1.8	1.1	1.4	1.6	1.0	1.3	1.5	0.9	1.1	1.4	0.8	1.1	1.3	
2.8	3.6	4.2	2.6	3.3	3.9	2.5	3.1	3.7	2.2	2.8	3.3	2.0	2.5	3.0	1.8	2.3	2.7	1.6	2.0	2.5	1.5	1.9	2.3	1.4	1.8	2.1	1.3	1.6	2.0	1.2	1.6	1.8	1.1	1.4	1.6	1.0	1.3	1.6	2.0
3.6	4.5	5.3	3.3	4.2	5.0	3.1	3.9	4.6	2.8	3.4	4.2	2.5	3.1	3.7	2.3	2.8	3.4	2.1	2.6	3.1	1.9	2.4	2.8	1.8	2.2	2.7	1.7	2.1	2.5	1.6	2.0	2.3	1.4	1.8	2.1	1.3	1.6	2.0	
4.4	5.5	6.6	4.1	5.1	6.2	3.8	4.8	5.8	3.4	4.3	5.2	3.1	3.9	4.6	2.8	3.5	4.2	2.6	3.2	3.9	2.4	3.0	3.6	2.2	2.8	3.3	2.1	2.6	3.1	1.9	2.4	2.9	1.7	2.1	2.6	1.6	2.0	2.4	
5.3	6.6	8.0	5.0	6.2	7.4	4.6	5.8	7.0	4.1	5.1	6.2	3.7	4.6	5.5	3.4	4.2	5.1	3.1	3.8	4.6	2.8	3.6	4.3	2.6	3.3	4.0	2.5	3.1	3.7	2.3	2.9	3.5	2.1	2.6	3.1	2.0	2.4	2.9	
6.1	7.7	9.2	5.7	7.2	8.6	5.4	6.7	8.1	4.8	6.0	7.2	4.3	5.4	6.4	3.9	4.9	5.9	3.6	4.5	5.4	3.3	4.1	5.0	3.1	3.8	4.6	2.9	3.6	4.3	2.7	3.4	4.0	2.4	3.0	3.6	2.3	2.8	3.4	
6.8	8.6	10.3	6.4	8.0	9.6	6.0	7.5	9.0	5.4	6.7	8.0	4.8	6.0	7.2	4.4	5.5	6.6	4.0	5.0	6.0	3.7	4.6	5.6	3.4	4.3	5.2	3.2	4.0	4.8	3.0	3.8	4.5	2.7	3.4	4.0	2.5	3.2	3.8	
7.6	9.5	11.4	7.1	8.9	10.7	6.6	8.3	10.0	5.9	7.4	8.9	5.3	6.6	8.0	4.8	6.0	7.3	4.4	5.6	6.6	4.1	5.1	6.2	3.8	4.8	5.7	3.6	4.4	5.3	3.3	4.2	5.0	3.0	3.7	4.4	2.8	3.5	4.2	
8.1	10.2	12.2	7.6	9.5	11.4	7.1	8.9	10.6	6.3	7.9	9.4	5.7	7.1	8.5	5.2	6.4	7.7	4.7	5.9	7.1	4.4	5.5	6.6	4.0	5.1	6.1	3.8	4.7	5.7	3.6	4.4	5.3	3.2	4.0	4.7	3.0	3.7	4.5	

MICRO GRANULAR PESTICIDE

ROW SPACING

TRANSMISSION		SPECIFIC WEIGHT OF THE PRODUCT KG/DM ³																																					
PE1 122	PS1 222	35 cm	37.5 cm	40 cm	45 cm	50 cm	55 cm	60 cm	65 cm	70 cm	75 cm	80 cm	90 cm	95 cm																									
		0.8	1	1.2	0.8	1	1.2	0.8	1	1.2	0.8	1	1.2	0.8	1	1.2	0.8	1	1.2	0.8	1	1.2																	
DOSING ADJUSTMENT		KG/HA																																					
A/6	5.5	6.9	8.2	5.1	6.4	7.7	4.8	6.0	7.2	4.3	5.4	6.4	3.9	4.8	5.8	3.5	4.4	5.2	3.2	4.0	4.8	3.0	3.7	4.4	2.8	3.5	4.1	2.6	3.2	3.9	2.4	3.0	3.6	2.1	2.7	3.2	2.0	2.5	3.1
A/8	5.7	7.3	8.7	5.3	6.8	8.1	5.0	6.4	7.6	4.5	5.7	6.8	4.1	5.1	6.1	3.6	4.7	5.5	3.4	4.2	5.1	3.1	3.9	4.7	2.9	3.6	4.4	2.7	3.4	4.1	2.5	3.2	3.8	2.2	2.8	3.4	2.1	2.7	3.2
B/0	7.1	8.9	10.5	6.6	8.3	9.8	6.2	7.8	9.2	5.5	6.9	8.2	4.9	6.2	7.4	4.5	5.7	6.7	4.1	5.1	6.2	3.8	4.8	5.7	3.5	4.4	5.3	3.3	4.1	4.9	3.1	3.9	4.6	2.8	3.5	4.1	2.6	3.2	3.9
B/5	8.9	11.2	13.3	8.3	10.5	12.4	7.8	9.8	11.6	6.9	8.6	10.4	6.2	7.8	9.3	5.7	7.1	8.4	5.2	6.5	7.8	4.8	6.0	7.1	4.4	5.6	6.7	4.2	5.2	6.2	3.9	4.9	5.8	3.5	4.4	5.2	3.3	4.1	4.9
C/0	11.0	13.7	16.5	10.2	12.8	15.4	9.6	12.0	14.4	8.6	10.7	12.9	7.7	9.7	11.6	7.0	8.7	10.5	6.4	8.1	9.7	5.9	7.4	8.9	5.5	6.9	8.3	5.2	6.4	7.7	4.8	6.0	7.2	4.3	5.3	6.4	4.1	5.1	6.1
C/5	13.3	16.5	19.9	12.4	15.4	18.6	11.6	14.4	17.4	10.3	12.8	15.4	9.2	11.5	13.8	8.4	10.5	12.7	7.7	9.6	11.5	7.1	8.9	10.7	6.6	8.2	9.9	6.2	7.7	9.2	5.8	7.2	8.7	5.2	6.4	7.7	4.9	6.1	7.3
D/0	15.3	19.2	23.1	14.3	17.9	21.5	13.4	16.8	20.2	11.9	14.9	17.9	10.7	13.4	16.1	9.7	12.2	14.7	8.9	11.2	13.4	8.2	10.3	12.4	7.7	9.6	11.5	7.2	8.9	10.7	6.7	8.4	10.1	6.0	7.5	9.0	5.7	7.1	8.5
D/5	17.1	21.5	25.8	16.0	20.1	24.1	15.0	18.8	22.6	13.4	16.7	20.0	12.0	15.0	18.0	10.9	13.7	16.4	10.0	12.5	15.0	9.2	11.6	13.9	8.6	10.7	12.9	8.0	10.0	12.0	7.5	9.4	11.3	6.7	8.4	10.0	6.3	7.9	9.5
E/0	19.0	23.8	28.6	17.7	22.2	26.7	16.6	20.8	25.0	14.8	18.5	22.2	13.3	16.6	20.0	12.1	15.1	18.2	11.1	13.9	16.6	10.2	12.8	15.4	9.5	11.9	14.3	8.9	11.1	13.3	8.3	10.4	12.5	7.4	9.2	11.1	7.0	8.8	10.5
E/5	20.3	25.4	30.4	19.0	23.7	28.4	17.8	22.2	26.6	15.7	19.7	23.6	14.2	17.7	21.3	12.9	16.1	19.3	11.8	14.8	17.7	11.0	13.7	16.4	10.1	12.7	15.2	9.4	11.8	14.2	8.9	11.1	13.3	7.9	9.9	11.8	7.5	9.3	11.2

MICRO GRANULAR PESTICIDE

ROW SPACING

TRANSMISSION		SPECIFIC WEIGHT OF THE PRODUCT KG/DM ³																																						
PE1 222	PS1 122	35 cm	37.5 cm	40 cm	45 cm	50 cm	55 cm	60 cm	65 cm	70 cm	75 cm	80 cm	90 cm	95 cm																										
		0.8	1	1.2	0.8	1	1.2	0.8	1	1.2	0.8	1	1.2	0.8	1	1.2	0.8	1	1.2	0.8	1	1.2	0.8	1	1.2	0.8	1	1.2	0.8	1	1.2	0.8	1	1.2	0.8	1	1.2	0.8	1	1.2
DOSING ADJUSTMENT		KG/HA																																						
B/0	14.4	18.1	21.5	13.4	16.9	20.1	12.6	15.8	18.8	11.2	14.0	16.8	10.1	12.6	15.1	9.2	11.5	13.7	8.4	10.5	12.6	7.8	9.7	11.6	7.2	9.0	10.8	6.7	8.4	10.1	6.3	7.9	9.4	5.6	7.0	8.4	5.3	6.6	8.0	
B/5	18.1	22.6	27.2	16.9	21.1	25.4	15.8	19.8	23.8	14.1	17.6	21.2	12.7	15.9	19.1	11.5	14.4	17.3	10.6	13.2	15.9	9.7	12.2	14.6	9.1	11.3	13.6	8.5	10.6	12.7	7.9	9.9	11.9	7.0	8.8	10.6	6.7	8.4	10.0	
C/0	22.6	28.1	33.8	21.1	26.2	31.6	19.8	24.6	29.6	17.5	21.9	26.3	15.8	19.7	23.7	14.4	17.9	21.5	13.1	16.4	19.7	12.2	15.1	18.2	11.3	14.1	16.9	10.5	13.1	15.8	9.9	12.3	14.8	8.8	10.9	13.2	8.3	10.4	12.5	
C/5	27.0	33.6	40.5	25.2	31.4	37.8	23.6	29.4	35.4	20.9	26.2	31.4	18.8	23.6	28.3	17.2	21.4	25.7	15.7	19.6	23.6	14.5	18.1	21.8	13.5	16.8	20.2	12.6	15.7	18.8	11.8	14.7	17.7	10.5	13.1	15.7	9.9	12.4	14.9	
D/0	31.3	39.1	46.9	29.2	36.5	43.7	27.4	34.2	41.0	24.3	30.4	36.5	21.9	27.4	32.9	19.9	24.9	29.8	18.3	22.8	27.4	16.9	21.0	25.2	15.6	19.6	23.5	14.6	18.3	21.9	13.7	17.1	20.5	12.2	15.2	18.2	11.5	14.4	17.3	
D/5	35.0	43.9	52.6	32.6	41.0	49.1	30.6	38.4	46.0	27.3	34.1	40.9	24.5	30.7	36.8	22.3	27.9	33.5	20.4	25.6	30.7	18.8	23.6	28.3	17.5	21.9	26.3	16.4	20.4	24.5	15.3	19.2	23.0	13.6	17.1	20.4	12.9	16.1	19.4	
E/0	38.9	48.5	58.3	36.3	45.2	54.4	34.0	42.4	51.0	30.2	37.7	45.3	27.2	34.0	40.8	24.7	30.8	37.1	22.6	28.3	34.0	20.9	26.1	31.4	19.4	24.3	29.1	18.1	22.6	27.2	17.0	21.2	25.5	15.1	18.8	22.7	14.3	17.9	21.4	
E/5	41.4	51.7	61.9	38.6	48.2	57.8	36.2	45.2	54.2	32.1	40.2	48.2	28.9	36.2	43.4	26.3	32.9	39.4	24.1	30.1	36.2	22.3	27.8	33.4	20.7	25.8	31.0	19.3	24.1	28.9	18.1	22.6	27.1	16.1	20.1	24.1	15.2	19.0	22.8	

Next to each dosing device, there is an adjusting wheel (Fig. 6.141). Turn it to adjust the fertilizer distribution.

The spindle has an adjusting scale marked from A to E, and the nut has 10 numbers for each letter. For each dosing device adjust the ratchet's letter to the nut's number (Fig. 6.141).



IT IS NOT RECOMMENDED USE POSITIONS LOWER THAN B/0 SINCE THEY MAY RESULT IN AN IRREGULAR DISTRIBUTION.

To empty the hoppers of the micro granular fertilizer and the micro granular pesticide, see sections 8.3 MICRO GRANULAR FERTILIZER'S AND/OR MICRO GRANULAR PESTICIDE'S HOPPERS



Fig. 6.141

6.21.1 CHANGING THE TRANSMISSION OF THE MICRO GRANULAR FERTILIZER WITH DOUBLE HOPPER.

The MICRO GRANULAR FERTILIZER is equipped with A DOUBLE COG WHEEL. The fertilizer dose to be distributed by the dosing devices can be adjusted by means of:

- The **MICRO GRANULAR FERTILIZER'S TRANSMISSION** (cogs **P.E.1** and **P.S.1**).

To change the micro granular fertilizer's transmission, follow these steps:

1- Remove the wing nut and the upper screw of the drive's lid (Fig. 6.142).



Fig. 6.142



Fig. 6.143

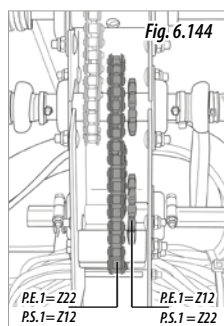

Fig. 6.144

P.E.1=Z22
P.S.1=Z12

P.E.1=Z12
P.S.1=Z22

2- Turn the lid downwards.

3- Using two wrenches, loosen the tensioners (Fig. 6.143).

4- Push the tensioner downwards to loosen the chain.

5- Change the chain's position (Fig. 6.144).

6- Tighten the chain using the 2 tensioners.

7- Lock the tensioner's position using the securing nuts.

8- Finally, close the lid and fix it using the screw and the wing nut.

6.21.2 CHANGING THE TRANSMISSION OF THE MICRO GRANULAR PESTICIDE WITH DOUBLE HOPPER

The micro granular pesticide is provided with TWO DOUBLE COGS. The dose to be spread by the dosing devices can be adjusted by means of:

- The **TRANSMISSION OF THE MICRO GRANULAR FERTILIZER** (cogs **P.E.1** and **P.S.1**).

- The **TRANSMISSION OF THE MICRO GRANULAR PESTICIDE** (cogs **P.E.2** y **P.S.2**).

To change the TRANSMISSION RATIO OF THE MICRO GRANULAR FERTILIZER (cogs P.E.1 and P.S.1), see **6.21.1 CHANGING THE TRANSMISSION OF THE MICRO GRANULAR FERTILIZER WITH DOUBLE HOPPER.**

To change the TRANSMISSION RATIO OF THE MICRO GRANULAR PESTICIDE (cogs P.E.2 and P.S.2), follow these steps:

1- Remove the lid's securing screws (1, Fig. 6.145).

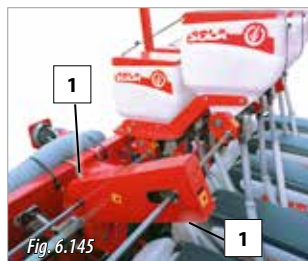

Fig. 6.145



Fig. 6.146

2- Loosen the chain using a wrench to operate on the tensioner's nut (2, Fig. 6.147).

3- Change the chain's position (Fig. 6.148)

4- Tighten again the chain using the tensioner. Fix its position by operating on the nut (2, Fig. 6.147).

5- Place the lid back and fix it using the screws (1, Fig. 6.145).

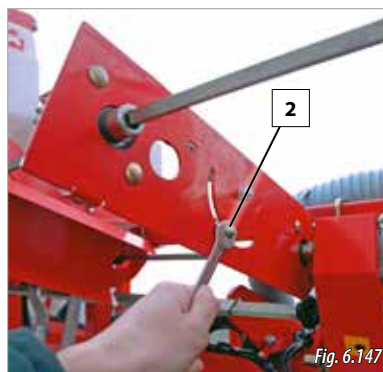

Fig. 6.147



Fig. 6.148

P.E.2=Z12
P.S.2=Z30

P.E.2=Z22
P.S.2=Z22

6.21.3 EXCLUDING THE FERTILIZER AND MICRO GRANULAR PESTICIDES

To disconnect the transmission of the micro granulator hoppers, it is necessary to operate on the transmission's box of the micro granulator hoppers (see section 3.1 PLANTER OVERVIEW). There are three types of gearbox, all of them have the clutch on one of the axles (shown in red, Fig. 6.149).

Disconnect the transmission when fertilizing the field is not required.

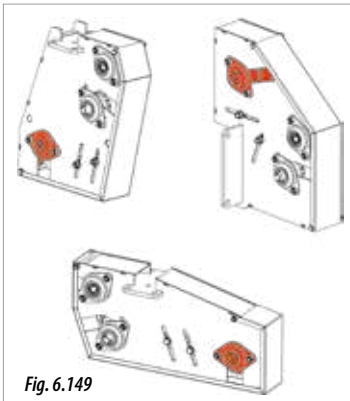

Fig. 6.149



Fig. 6.150

To exclude the transmission, follow these steps:

- 1- Remove the wing nut and the upper screw of the drive's lid (Fig. 6.150).
- 2- Turn the lid downwards.
- 3- In the transmission axle where the clutch is (Fig. 6.149), pull the securing knob and turn it 90° to lock it at the free transmission position (Fig. 6.151).
- 4- Close the lid and fix it using the screw and the wing nut.

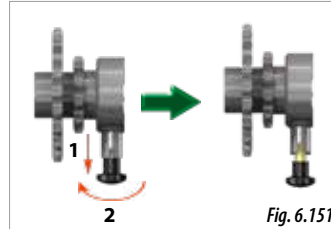

Fig. 6.151

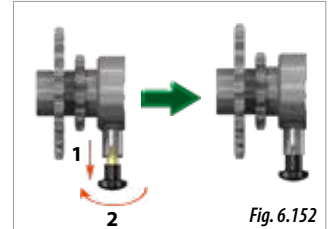

Fig. 6.152

To reconnect the transmission:

- 1- Remove the wing nut and the upper screw of the drive's lid (Fig. 6.150).
- 2- Turn the lid downwards.
- 3- In the transmission axle where the clutch is (Fig. 6.149), pull the securing knob and turn it 90° to lock it at the transmission position (Fig. 6.152).
- 4- Close the lid and fix it using the screw and the wing nut.

7- TRANSPORT



ALL MACHINES CAN RUN ON PUBLIC ROADS, YET ARE PROHIBITED IF EQUIPPED WITH FIXED FRAME OR VARIANT MANUAL FIXED FRAME WHOSE WIDTH IS NOT ALLOWED ACCORDING TO EACH COUNTRY'S LEGISLATION. IN THESE CASES, RUNNING ON PUBLIC ROADS WILL ONLY BE LEGAL IF THE MACHINE HAS THE OPTIONAL LONGITUDINAL TRANSPORT TROLLEY.



BEFORE FOLDING OR UNFOLDING THE TRACK MARKERS, MAKE SURE NO HIGH-VOLTAGE OVERHEAD LINES HANGING TOO LOW, SINCE THE TRACK MARKERS MAY TOUCH THEM AS RESULT OF THE ADJUSTMENTS PERFORMED TO THEM OR DUE TO THE TERRAIN'S CONDITIONS.

- 3- Unfold the drawbar so that it stays aligned to the planter's frame.
- 4- Couple the planter's drawbar to the tractor using the tractor's two low points. Plug the drawbar's hydraulic connection to the tractor.
- 5- Lower the transport wheels (1, Fig. 7.3) until the side of the planter where the transport wheels are attached raises.
- 6- Raise the tractor's two lower arms (2, Fig. 7.3).



7.1 FIXED FRAME

To set planters with **ALLOWED FRAME WIDTH** for transit:

- 1- Fold the track markers. Once they are folded, their position needs to be locked by following next steps. Depending on the type of track marker (A or B) do as required:
 - A. Place the security handle (2, Fig. 7.1) and, next, place the pin (1, Fig. 7.1).
 - B. Pull the knob (3, Fig. 7.2) and shift the fixing piece downwards until it fits into the transit position (4, Fig. 7.2).
- 2- Raise the planter.

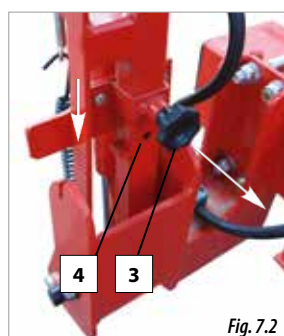
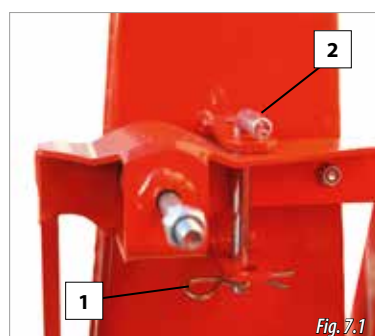

7.2 VARIANT MANUAL FIXED FRAME

To set planters with **ALLOWED FRAME WIDTH** for transit:

- 1- Fold the track markers. Once they are folded, their position needs to be locked by following next steps. Depending on the type of track marker (A or B) do as required:
 - A. Place the securing handle (2, Fig. 7.4) and, next, place the pin (1, Fig. 7.4).
 - B. Pull the knob (3, Fig. 7.5) and shift the fixing piece downwards until it fits into the transit position (4, Fig. 7.5).
- 2- Raise the planter.

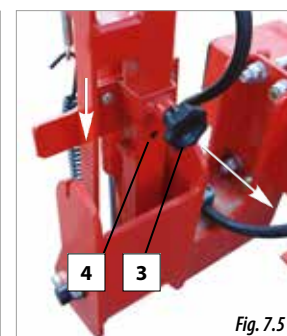
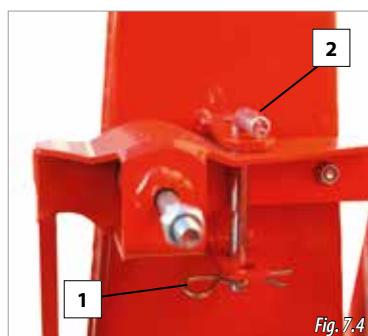

To set planters with **LONGITUDINAL TRANSPORT TROLLEY** for transit:

- 1- Fold the track markers. Once they are folded, their position needs to be locked by following next steps. Depending on the type of track marker (A or B) do as required:
 - A. Remove the pin (1, Fig. 7.1) and remove the securing handle (2, Fig. 7.1).
 - B. Pull the knob (3, Fig. 7.2) and shift the fixing piece upwards until it fits into the working position (4, Fig. 7.2).
- 2- Uncouple the planter from the tractor and disconnect all electric and hydraulic connections.

7.3 TELESCOPIC, VARIANT AND VARIANT IDRA FRAME

To set planters equipped with TELESCOPIC, VARIANT OR VARIANT IDRA FRAME NOT WIDER THAN 3 METRES for transit:

- 1- Fold the track markers. Once they are folded, their position needs to be locked by following the next steps. Depending on the type of track marker (A or B) do as required:

- A. Place the securing handle (2, Fig. 7.4) and, next, place the pin (1, Fig. 7.4).
- B. Pull the knob (3, Fig. 7.5) and shift the fixing piece downwards until it fits into the transit position (4, Fig. 7.5).

2- Raise the planter.

3- Fold the telescopic folding parts (Fig. 7.6).



- 3- Fold the central frame (Fig. 7.8) of the machine, except in folding planters equipped with central fixed frame or variant manual frame.
- 4- Fold the planter's lateral folding parts (Fig. 7.9).

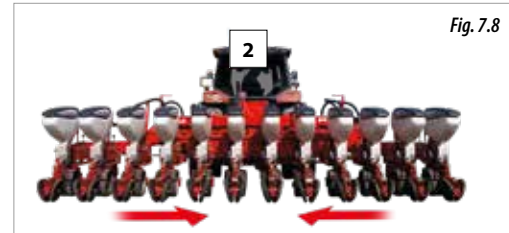
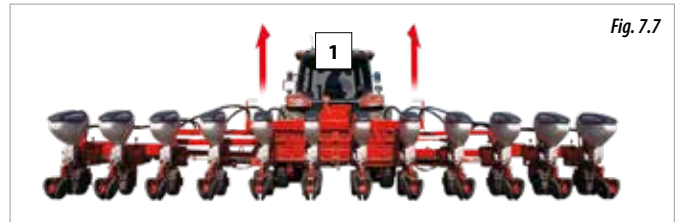

7.4 FOLDING FRAME

All types of machines equipped with this frame are allowed in thoroughfare. To set the planter for transit, follow these steps:

- 1- Fold the track markers hydraulically.
- 2- Raise the planter (Fig. 7.7).

8. FILLING AND EMPTYING THE HOPPERS



CHECK THAT THE PLANTER IS EMPTY, CLEAN AND DRY.



DO NOT DEPOSIT EXTERNAL ELEMENTS INSIDE THE HOPPER. BEFORE FILLING IT CHECK THAT IT CONTAINS NO OBJECT AND THE SEED OUTLET IS NOT BLOCKED.

8.1 SEED HOPPER

The planter is equipped with a 50 L capacity seed hopper for each metering unit.

To **FILL** the seed hoppers, first check that there is no seed residue inside the hoppers and, next, fill them all with certified seeds.



FILL ONLY THE HOPPERS OF THE METERING UNITS WHICH ARE TO BE USED.

To **EMPTY** the metering units' hoppers, follow these steps:

- 1- Manually turn the emptying gate to its open position (A, Fig. 8.1).
- 2- Once the hopper has been emptied, return the emptying gate to its closed position (B, Fig. 8.1).

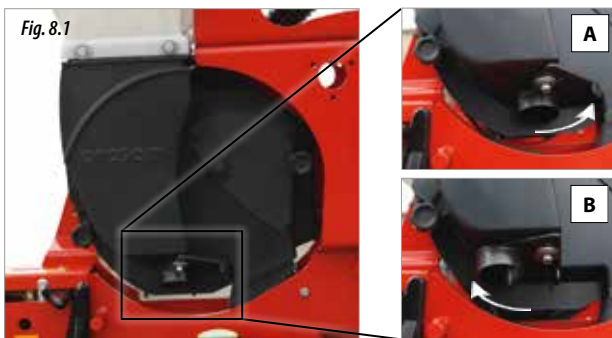

8.2 FERTILIZER HOPPER

Planters with fertilizing equipment can have fertilizer hoppers of 210, 300, 700, 800 or 1080 L (capacity of a single hopper).

In order to safely and quickly **FILL** the fertilizer hoppers, the best way is using a WORM DRIVE.

A hydraulic crane can also be used to raise the BIG BAG above the hopper in order to fill it. Check that the whole bag volume fits into the hopper.

To secure the BIG BAG to the crane, follow the instructions provided by its manufacturer.



BEFORE FILLING THE FERTILIZER HOPPER, MAKE SURE IT DOES NOT CONTAIN ANY REMAINDERS OF CHEMICAL PRODUCTS. IF THEY EXIST, THE HOPPER NEEDS TO BE EMPTIED AND CLEANED.



To **EMPTY** the fertilizer hoppers, open the caps placed on the hopper's lower part (A, Fig. 8.2).



AFTER USING THE FERTILIZING EQUIPMENT, EMPTY AND CLEAN THE HOPPERS (SEE SECTION 9.6 MACHINE CLEANING).



IF THESE OPERATIONS ARE PERFORMED IN A DIFFERENT WAY THAN EXPLAINED ABOVE, THE MANUFACTURER WILL NOT BE HELD RESPONSIBLE FOR ANY DAMAGE TO PERSONS, GOODS OR TO THE PLANTER ITSELF.

8.3 MICRO GRANULAR FERTILIZER'S AND/OR MICRO GRANULAR PESTICIDE'S HOPPERS

Planters with fertilizer or micro granular pesticide are equipped with a 28 L capacity hopper for every two rows.

To **FILL** the micro granulators, first check that there is no any product remainder inside the hoppers. If exist, empty and clean the hopper and, next, proceed filling.



AFTER USING THE INSECTISIDE OR MICRO GRANULAR PESTICIDE EQUIPMENTS, EMPTY AND CLEAN THE HOPPERS (SEE SECTION 9.6 MACHINE CLEANING).



To fill the hoppers of the micro granular fertilizer or the micro granular pesticide, use a ladder.

To **EMPTY** the hoppers of the fertilizer or micro granular pesticide, open the caps placed on the hopper's lower part (B, Fig. 8.3).

9- MAINTENANCE



IN CASE OF MALFUNCTION, STOP THE PLANTER IMMEDIATELY AND REMOVE THE IGNITION KEY. LEAVE THE TRACTOR AND VISUALLY INSPECT AND EVALUATE THE EXTENT OF THE PROBLEM. PERFORM THE REQUIRED OPERATIONS ON THE PLANTER BEFORE RESTARTING IT.



MAINTENANCE OPERATIONS MUST BE PERFORMED IN PROPERLY EQUIPPED GARAGES BY QUALIFIED PERSONNEL.



NO REPAIRS SHOULD BE PERFORMED WITHOUT THE NECESSARY SKILLS AND KNOWLEDGE. IT IS ESSENTIAL THAT THE INSTRUCTIONS DETAILED IN THIS MANUAL ARE STRICTLY FOLLOWED. IF THESE INSTRUCTIONS ARE MISSING, PLEASE CONTACT THE PLANTER'S PROVIDER OR QUALIFIED PERSONNEL.



IN ORDER TO PERFORM MAINTENANCE OR REPAIR OPERATIONS TO THE PLANTER, IT IS ESSENTIAL TO USE PROPER **PERSONAL PROTECTIVE EQUIPMENT** (PPE): SAFETY BOOTS AND GLOVES, HEARING PROTECTION, DUST MASK AND PROTECTIVE GLASSES).



IT IS RECOMMENDED TO AVOID WEARING LOOSE CLOTHING SINCE IT MAY BECOME TANGLED WITH THE PLANTER'S MOVING PARTS.

Before performing any task on the machine, it is essential to take into account the following factors:

- Maintaining or repairing the planter should be performed on a flat and compact ground. Before starting any of these tasks, the tractor's engine must be turned off and the ignition key removed.
- The chosen device to raise the planter needs to be appropriate for the operations to be performed. Please ensure that all safety regulations are observed.
- Always use appropriate protective equipment for any task to be performed.
- In case compressed air is used to clean the planter, or an airbrush is used to paint any planter's part, you are required to wear protective glasses and mask.
- If any operation needs to be performed on a part of the machine which is at more than 1,5 metres height from the ground, check if it is possible to reach this part using the planter's access points (planter's access ladder). If not possible, use either a ladder or a platform which is in accordance with the current safety regulations.
- Prolonged and/or repetitive skin contact with fuel and lubricants is harmful. In case these products come accidentally into contact with the eyes or other sensitive parts, wash well the affected parts with clean water. In case of ingestion, contact the medical services immediately.

9.1 CHECKING FREQUENCY

The frequency of the checks indicated below is provided as a guideline. It may vary depending on machine application and use, environment, temperature, weather conditions, etc.

- BEFORE STARTING THE SOWING SEASON:

Check the general operation of the planter. Perform this check without any seeds inside the hopper.
Check that the plastic components of the planter are in good condition. The wear of this material due to natural ageing or to the presence of rodents causes damages to these components.
Check that the mechanical components are in good condition and not rusty.
Clean the parts of the planter which are permanently in contact with seeds, such as hoppers and metering boxes.
Check that the signal lamps work properly.
Check that the unions and the ducts of the hydraulic system do not show oil leaks.

- PERIODICALLY:

Before washing the planter with water, check that no seeds or fertilizer are inside the hoppers or the metering boxes. After washing the machine, turn on the fan for some minutes in order to remove the moisture from the metering units and the suction system.
Check that all the screws are in good condition, especially the ones which are in contact with the ground. Tighten every single screw and bolt.
Check that the metering boxes and the suction system do not contain any residue (such as seed or fertilizer residue, dust, etc). Residue accumulation may damage the suction system.

- END OF SOWING SEASON

Wash the planter well with a lot of water, making sure that no seeds, fertilizer or other products remain inside the hoppers, metering boxes or ducts. Wash especially the parts of the planter which are in contact with chemical products.
Properly lubricate the moving parts of the planter (see section 9.2 GREASING AND LUBRICATION).
Repaint any metallic component which has lost its paint due to wear.
To store the planter properly, cover it with tarpaulin and keep it in a dry place.
Thoroughly check all components of the planter and replace the ones which are damaged or worn.



KEEP THE SOWING EQUIPMENT CLEAN. THE ACCUMULATION OF EARTH, STONES, GRASS, ETC. MAY BLOCK THE SOWING DUCTS.

A careful maintenance of the planter ensures proper functioning and long service life of the machine.



BEFORE PERFORMING THESE OPERATIONS, THE PLANTER'S ENGINE MUST BE TURNED OFF AND THE IGNITION KEY REMOVED.

The next table shows the maintenance operations to be performed on the machine along with their (GUIDANCE) frequency:



AFTER THE FIRST 10 HOURS OF WORK, TIGHTEN THE SCREWS THAT SECURE THE METERING UNITS, THE THREE POINT LINKAGE, THE WHEELS AND THE TRACK MARKERS' SUPPORTS.

PLANTER'S PART	TASK TO BE PERFORMED	NUMBER OF HOURS			
		20	50	100	500
Machine's components	Greasing of all the components	•	•		
Fan	Adjusting the belt's tension (in versions equipped with mechanical fan)				•
Drive wheels	Check of the tyre pressure			•	
	Replace the transmission's fusible pin				•
Chain transmissions	Lubrication of the transmission chains		•		
	Adjusting the transmission chains' tension				•
Metering box	Lubrication of the transmission chains			•	
Gearbox	Oil change	Every 5 years			

The following parts of the planter should be greased:

- Track markers (Fig. 9.3)
- Driving wheels' bushings (Fig. 9.4).
- Each component of the transmission (Fig. 9.5).
- Each component of the metering units (Fig. 9.6).
- Each PTO shaft and plastic axle of the PTOs (Fig. 9.7).

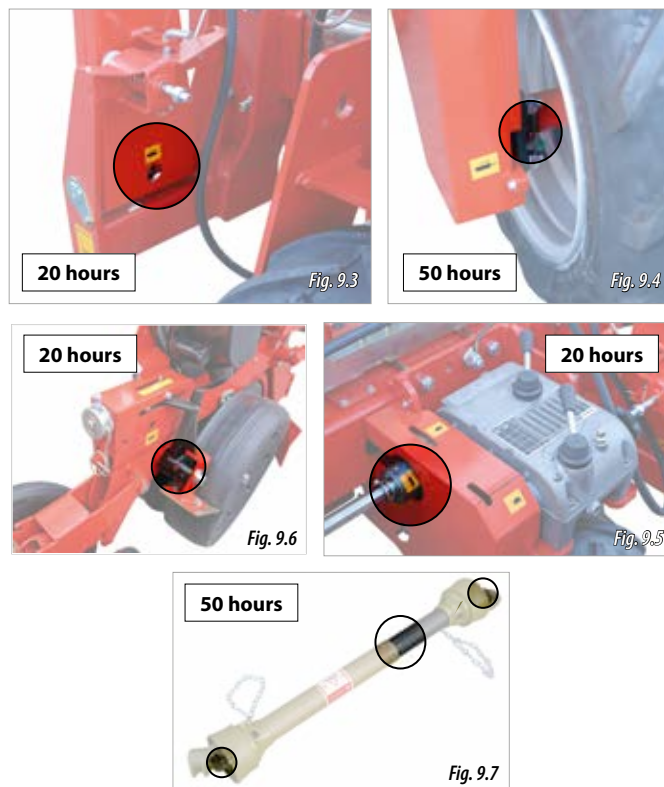

9.2 GREASING AND LUBRICATION

Every non-painted metallic component of the planter is exposed to atmospheric and weather conditions, which may oxidize them. For this reason, it is important to grease and lubricate these components.

Attached to specific parts of the planter, you will find adhesives with symbols to indicate the parts to be GREASED (Fig. 9.1) or the points to be LUBRICATED (Fig. 9.2).

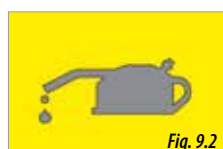
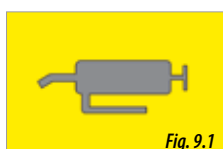

BEFORE LUBRICATING OR GREASING, WASH THE PLANTER TO REMOVE EARTH RESIDUES ATTACHED TO THE MACHINE (see section 9.6 MACHINE CLEANING).



TO GREASE THESE PARTS, ALWAYS USE SOLID CALCIUM GREASE.



SOME PARTS OF THE MACHINE NEED TO BE GREASED EVERY 50 WORKING HOURS (SEE SECTION 9.1 CHECKING FREQUENCY). NOT OBSERVING THESE GREASING RULES MAY RESULT IN DAMAGE TO THE PLANTER.

Each transmission chain of the following parts should be LUBRICATED:

- Transfer box in models equipped with automatic gearbox (Fig. 9.8).
- Transmission chains in models equipped with non-automatic gearbox (Fig. 9.9).
- Transfer box in fertilizer/micro granular pesticides and fertilizing equipments (Fig. 9.10 and Fig. 9.11).
- Transmission chains of each metering unit (Fig. 9.12).

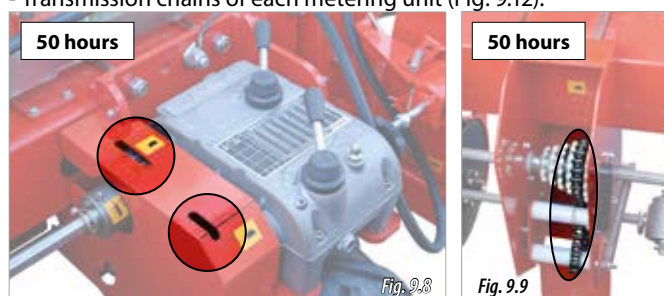

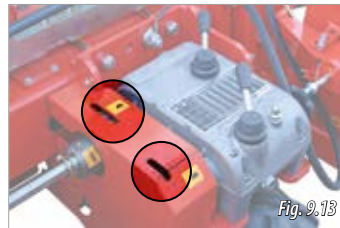

ALWAYS USE HIGH PERFORMANCE OIL TO GET A RELIABLE LUBRICATION.

Every roller's chain should be properly lubricated after finishing the sowing season as well as after a long period of time without using the planter.

Some transmission protectors have quick access points for the chain lubrication (Fig. 9.13). When lubricating through these quick access points, raise the machine and turn the transmission by turning manually the drive wheels. Make sure that the whole unit has been impregnated with the lubricant. However, it is recommended to first remove the chain protectors, next lubricate and finally place the protector back. In this way we make sure that the lubrication is performed properly.

9.3 FANS



KEEP THE AIR OUTLETS FREE.



BEFORE STARTING THE SOWING SEASON, CHECK THAT THE DUCTS OF THE AIR CIRCUIT ARE IN GOOD CONDITION.

Mechanical fans

Check the condition of the timing belts since natural wear may cause looseness.

To extend the service life of the timing belt, the machine is equipped with a tensioning system. To adjust it, follow these steps:

- 1- Loosen the wing nuts (1, Fig. 9.14) in order to remove the transmission's lid (2, Fig. 9.14).
- 2- Loosen the four nuts of the tensioner (3, Fig. 9.14).
- 3- Operate on the screw (4, Fig. 9.14) to adjust the tension of the belt.

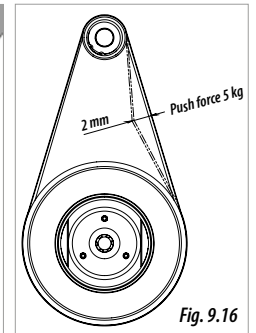
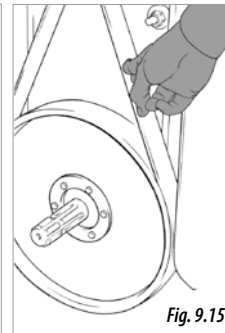
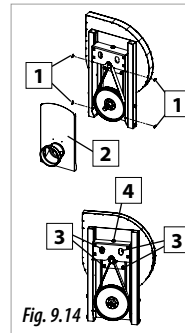

CHECK THE TENSION OF THE TIMING BELT BY PRESSING ON IT (FIG. 9.15). CHECK THAT ITS TENSION IS OPTIMAL BY APPLYING A 5 KG LOAD ON THE POINT THAT IS EQUIDISTANT FROM THE PULLEYS' AXLES. IF THE TENSION IS OPTIMAL, THE TIMING BELT SHOULD SHIFT 2 MILLIMETRES AS A CONSEQUENCE OF APPLYING THIS PUSH FORCE (Fig. 9.16).

- 4- Tighten the nuts (3, Fig. 9.14) to lock the pulley's position.
- 5- Place the lid back and tighten the wing nuts (1, Fig. 9.14).

Hydraulic fans



ALWAYS KEEP THE HYDRAULIC CONNECTIONS IN GOOD CONDITION. THE PRESSURE OF THE HYDRAULIC CIRCUIT MAY CAUSE SERIOUS DAMAGE TO PERSONS. PRESSURE LOSSES IN THE HYDRAULIC CIRCUIT WILL RESULT IN A LACK OF SEEDS IN THE SEED DISC.

9.4 TRANSMISSION CHAIN

All chains in the chain transmissions need to be properly lubricated to work optimally.

Most types of transmission chains have **AUTOMATIC TENSIONERS** with spring. For this reason, it is not necessary to manually adjust their tension (Fig. 9.17).

However, some chain transmission have **FIXED TENSIONERS** (Fig. 9.19) which need to be manually tensioned following these steps:

- 1- Remove the securing screws (1, Fig. 9.18) to remove the lids.
- 2- Using two wrenches, loosen the tensioners (Fig. 9.20).
- 3- Push the tensioners towards the chain until it is properly tensioned



CHECK THAT ALL THE TRANSMISSION CHAINS OF THE PLANTER ARE TENSIONED. IN THE CASE THAT A CHAIN IS NOT TENSIONED, CHECK THE CHAIN'S CONDITION AND REPLACE IT IF NECESSARY.



PERIODICALLY LUBRICATE THE TRANSMISSION CHAINS (SEE SECTION 9.2 GREASING AND LUBRICATION).

9.5 AUTOMATIC GEARBOX

Periodically check the oil level of the gearbox using the oil sight glass (1, Fig. 9.21).



WHEN THE OIL LEVEL REACHES THE MARK IN THE CENTRE OF THE OIL SIGHT GLASS, THAT MEANS THAT THE OIL LEVEL IS OPTIMAL (Fig. 9.22).

To fill the oil tank:

- 1- Remove the cap (2, Fig. 9.21)
- 2- Fill the tank. Check the level using the oil sight glass (1, Fig. 9.21).
- 3- Place the cap back.

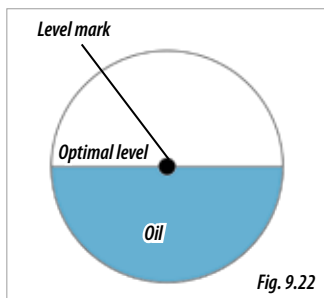

IT IS RECOMMENDED TO CHANGE THE OIL EVERY 5 YEARS, REGARDLESS OF THE USE OF THE PLANTER. TO CHANGE THE OIL, ALWAYS USE OIL TYPE SAE 30 (APPROXIMATELY 2 LITRES).

9.6 MACHINE CLEANING

The planter should be washed using a water jet or preferably using a high-pressure cleaner. Let the planter dry before greasing or lubricating to prevent the metallic parts from rusting.

After washing the machine, turn on the fan for some minutes in order to remove the moisture from the metering units and the suction system.

It may be possible that, while working, some foreign bodies are stuck in some parts of the planter, such as the fertilizer's discs and the seed discs. Check that these discs are turning properly. Otherwise, take the component apart and remove any foreign body.



EVERY TIME THE SEED HOPPER IS CLEANED USING COMPRESSED AIR, USE PROPER **PERSONAL PROTECTIVE EQUIPMENT (PPE)** (see section 9- MAINTENANCE).



IMPORTANT: ALWAYS KEEP THE AIR RESERVOIR CLEAN (1, Fig. 9.23) AND PERIODICALLY CHECK IT IS IN GOOD CONDITION.



IN PLANTER'S MODELS EQUIPPED WITH **FOLDING FRAME**, CLEAN THE MAIN AIR RESERVOIR (1, FIG. 9.24) AND THE AIR RESERVOIRS OF THE FOLDING PARTS (2, FIG. 212). PERFORM THIS OPERATION ONLY WHEN THE PLANTER IS OPEN (FIG. 9.24).

To clean the air reservoir, follow these steps:

- 1- Remove the screws and nuts from the two laterals of the air reservoir (1, Fig. 9.25) and, next, remove the lids.
- 2- Use compressed air to blow air into the air reservoir.
- 3- Place the lids, screws and nuts back.

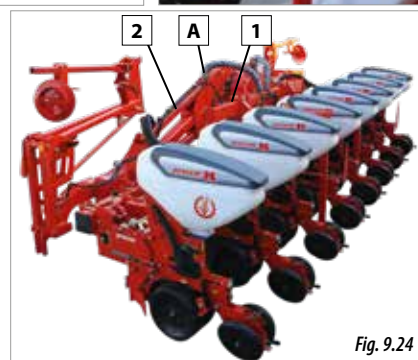

CHECK THAT THE LIDS ARE PROPERLY PLACED. IF NECESSARY, USE SILICONE TO SEAL THE LID'S SIDES WHICH ARE IN CONTACT WITH THE AIR RESERVOIR.

In FOLDING versions of the machine, the air reservoir of the folding parts needs to be cleaned as well. To perform the cleaning, follow these steps:

- 1- Remove the suction duct that connects the main air reservoir to the folding parts' air reservoir (A, Fig. 9.24 or 9.26).
- 2- Remove the lower cap of the folding parts' air reservoir (B, Fig. 9.26).
- 3- Use compressed air to blow air into the folding parts' air reservoir in the direction indicated by the arrows in Fig. 9.26.
- 4- Place the lower cap back (B, Fig. 9.26) and connect the suction duct (A, Fig. 9.26).

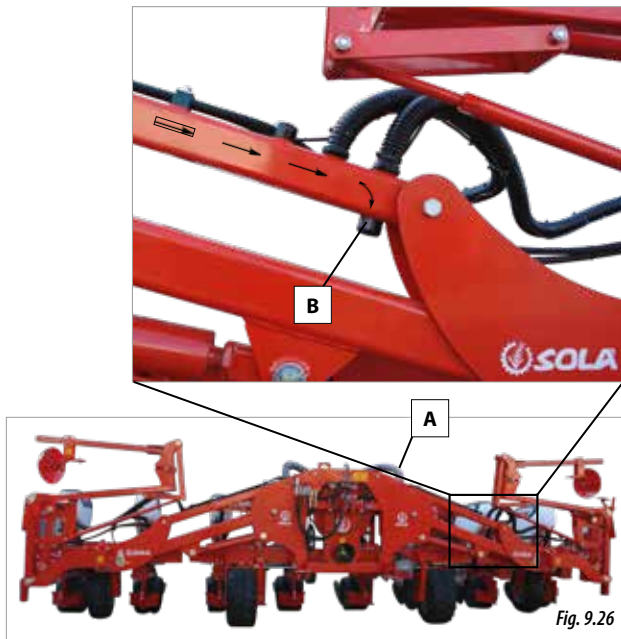

Fig. 9.26

9.7 SCREWS

All the securing screws which fix the components to the planter need to be checked and tightened if necessary after the first 10 hours of work. Especially check the securing screws of the metering units, the three-point frame, the wheels and the supports of the track markers.

9.8 TYRE PRESSURE

Before starting working with the planter, check that the tyre pressure is correct.

TYRE TYPE	AIR PRESSURE (bar)
6,5/80 - 15 4PR	1,5
23x8,50 - 12" 4PR	1,5
23x8,50 - 12" 6PR	2
23x8,50 - 12" 8PR	2,5
23x10,50 - 12" 4PR	1,5
23x10,50 - 12" 8PR	2,5
26x12 - 12" 8PR	2,5

MAQUINARIA AGRÍCOLA SOLÀ, S.L.

Ctra. de Igualada, s/n. Apdo. Correos, 11
08280 CALAF (Barcelona) **SPAIN**

Tel. 34 93 868 00 60*

Fax. 34 93 868 00 55

www.solagrupo.com

e-mail: sola@solagrupo.com

