

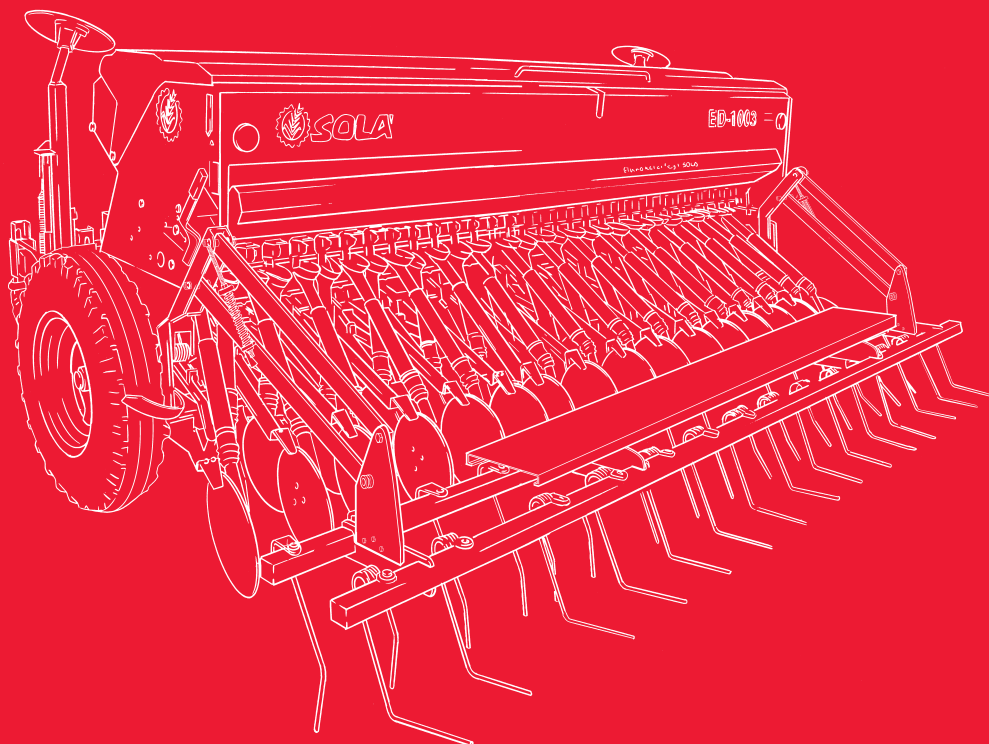

ED-1003



STARTING MANUAL  
MAINTENANCE  
DOSAGE  
SPARE PARTS

---

Please read and follow this operating manual  
before putting the machine into operation.

SOLÀ seed drills and fertilizer spreaders are manufactured in a highly specialized environment and our factory has a vast customer-endorsed experience.

SOLÀ machines use highly advanced technology and are guaranteed to work without malfunctions in a great variety of conditions. They are provided with easy-to-use and efficient devices. SOLÀ machines perform excellently with only minimum operator maintenance.

This manual will help you use your SOLÀ product with the upmost efficiency.



Certified quality system

4th Edition – August 2012  
Ref.: CN-811037/GB

It is forbidden to copy any part of this manual.  
Specifications are subject to change or modification without notice.  
The pictures included do not necessary show the standard version.

# TABLE OF CONTENTS

<b>1 - Introduction</b> .....	5
<b>2- Technical characteristics</b> .....	7
2.1 ED-1003.....	7
2.2 ED-1003 GC.....	7
2.3 Standard equipment.....	7
2.4 Optional equipment.....	7
<b>3-Safety Instructions</b> .....	9
3.1 Safety symbols.....	9
3.2 Use according to design.....	11
3.3 General safety regulations .....	11
3.4 Loading and unloading instructions.....	13
<b>4-Essential sowing concepts</b> .....	15
4.1 Terrain .....	15
4.2 Seeds.....	15
4.3 Seed planting depth.....	15
<b>5- Starting</b> .....	19
5.1 Coupling.....	19
5.2 Dosing system.....	20
5.3 Seed dosing.....	21
5.4 Calibration test.....	22
5.5 Field test.....	24
5.6 Seed dosing adjustments.....	25
5.7 Dosing system in combined seed drills (seeds and fertilizer).....	27
5.8 Double hoppers in combined seed drills.....	27
5.9 Fertilizer dosing in combined seed drills.....	28
5.10 Hopper levelling and disc coulter's adjustments.....	30
<b>6 – Accessories</b>	
6.1 Cultivator.....	32
6.2 Leveller.....	33
6.3 Wheel's scrapers.....	34
6.4 Harrow with flexible tines, Model EPI-6.....	35
6.5 Track markers.....	36
6.6 Hectare counter.....	38

## TABLE OF CONTENTS

<b>7 - Maintenance</b> .....	41
7.1 Lubrication.....	41
7.2 Tyres pressure.....	43
7.3 Screws .....	43
7.4 Anti-rust control (combined machine).....	43
<b>8 - Dosage tables</b> .....	45
8.1 Seed dosage table (kg/ha).....	46
8.2 Fertilizer dosage table.....	48
<b>9 – Spare parts</b> .....	49
9.1 Introduction.....	49
9.2 Chassis.....	50
9.3 Discs ED-1003.....	54
9.4 Seed variator.....	60
9.5 Fertilizer variator.....	64
9.6 Hopper. Combiner seed drill.....	68
9.7 Big capacity hopper. Combiner seed drill.....	72
9.8 Combined seed drill. Distribution.....	74
9.9 Flexible harrow.....	78
9.10 Articulated harrow 4 meters.....	80
9.11 «Ransome» track erasers.....	82
9.12 ED harrow.....	84
9.13 «Spring» track erasers.....	86
9.14 Integrated cultivator.....	88
9.15 Floating cultivator.....	92
9.16 Double smooth leveller / Double spring tines leveller.....	96
9.17 Hectare counter.....	98
9.18 Mechanical track markers.....	100
9.19 Automatic coupling.....	102
9.20 Automatic coupling for floating cultivator.....	104
9.21 Finishing.....	106



# 1 - INTRODUCTION

It is essential to read and follow the instructions and recommendations in this manual before operating the seed drilled-1003. Careful reading enables maximum operator efficiency, prevents accidents and damage, and increases the seed drill's capacity and life expectancy.

Please ensure that this manual has been read by any person involved in performing operational tasks, (including preparation, dealing with mechanical problems and supervising the machine), maintenance (inspection and technical assistance) and transport.

For your safety, please follow these technical safety instructions as SOLÀ will not be responsible for damages caused by not observing the information provided.

In the first chapters you will find the Technical Characteristics and Safety Instructions, as well as some essential sowing concepts. Basic concepts that are required to operate the machine are explained in the Starting and Maintenance sections.

The last part of this manual consists of Dosage Tables, detailed by seed type.



SOLÀ RETAINS THE RIGHT TO MODIFY ILLUSTRATIONS, TECHNICAL DATA AND WEIGHTS INDICATED IN THIS OPERATING MANUAL, IF THESE CHANGES HELP TO IMPROVE THE QUALITY OF THE SEED DRILLS.



## 2.- TECHNICAL CHARACTERISTICS

### 2.1 ED-1003

Type / Rows	Rows spacing	Working width	Transport width	Seed Hopper capacity		Weight (kg)	Tyre type
				Litres	Kilos		
250/21	12 cm	2,50 m	2,68 m	540	390	760	6.00-19
300/25	12 cm	3,00 m	3,17 m	665	480	890	6.00-19
350/29	12 cm	3,50 m	3,74 m	790	570	990	7.50-16
400/33	12 cm	4,00 m	4,23 m	920	660	1090	7.50-16

### 2.2 ED-1003 GC

Type / Rows	Rows spacing	Working width	Transport width	Seed Hopper capacity		Weight (kg)	Tyre type
				Litres	Kilos		
300/25	12 cm	3,00 m	3,17 m	866	625	931	7.50-16
350/29	12 cm	3,50 m	3,74 m	1027	740	1060	7.50-16
400/33	12 cm	4,00 m	4,23 m	1188	860	1155	7.50-16

### 2.3 STANDARD EQUIPMENT

- Gearbox.
- Tines leveller.
- Calibration cup, scales, crank and seed counter.
- Arrow indicating the seed level.
- Wheel's scrapers.
- Seed selecting sieve (only in combined machines).

### 2.4 OPTIONAL EQUIPMENT

- Harrow with flexible tines.
- "Ransome" track eraser.
- Track eraser with spring.
- Hectare counter.
- Hydraulic track markers.
- Gearbox's hydraulic control.
- Floating cultivator.
- Automatic coupling.
- Integrated cultivator.



## 3.- SAFETY INSTRUCTIONS

### 3.1 SAFETY SYMBOLS

In this operating manual you will find three different symbols relating to safety:



TO WORK MORE EASILY WITH THE SEED DRILL.



TO PREVENT DAMAGE TO THE SEED DRILL AND OPTIONAL EQUIPMENT.



TO PREVENT PHYSICAL INJURY.

On the machine you will find the following warning pictograms:



Read the instructions carefully and observe the safety advice given in the operating manual.



Never stand under the track markers nor inside their action area. Risk of serious physical injury.



During the coupling manoeuvre, stay away from the rear part of the tractor. Risk of serious physical injury.



While maintaining or repairing the seed drill, stop the tractor's engine and prevent it from starting. The ignition key must be removed

En la máquina hallará los siguientes rótulos de aviso:



Danger of infection from escaping hydraulic fluid at high pressure! This can inflict serious injuries with potentially fatal consequences if it passes through the skin and into the body. Keep the hose lines in good condition. Risk of serious physical injuries.



It is forbidden to ride on the machine during operation. Risk of serious physical injuries.



Risk of being crushed when working under the machine, please secure the machine to prevent this risk. Risk of serious physical injuries.

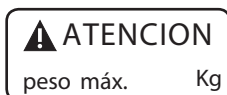

Do not exceed maximum load.

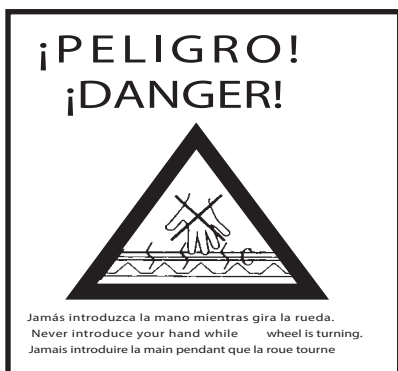

Do not insert your hand into the hopper while the drive wheel is turning.

Risk of serious physical injury.

### 3.2 USE ACCORDING TO DESIGN

- The Seed Drill ED-1003 has been designed for normal use in agricultural work, especially cereal and other kind of grain seeds.
- If the machine is used in circumstances other than the above, the manufacturer will not be held responsible for any damage caused.
- The user must observe all regulations concerning safety, traffic and hygiene.
- If the machine is modified by the user, the manufacturer's warranty is cancelled. SOLÁ will not be held responsible for any damage caused.

### 3.3 GENERAL SAFETY REGULATIONS

- Before starting the machine, please check the machine is in good condition for work and is safe for road use. Check that visibility is clear around the machine and there is no person in the working area,
- In thoroughfare, please observe traffic signs and regulations.
- It is forbidden to ride on the machine or climb into the machine when it is running.
- Before using the machine, the user must be familiar with all operating elements.
- Please be extremely careful when coupling and uncoupling the machine to the tractor.

- While performing dosing tests, be careful with possible dangers caused by turning pieces. Pay special attention to the agitator's tines from inside the hopper, as well as the wheel drive's scraper.
- Fast-locking hooks must stay unlocked. They should always remain closed and should only be opened when the machine is on the ground to be uncoupled.
- Never leave the tractor's driver's seat while the machine is in operation.
- Do not deposit external elements inside the hopper.
- When maintaining the hydraulic system of the seed drill, make sure that it is depressurised and tractor's engine is off.
- Please regularly check the condition of the tubes and hosepipes in the hydraulic system. These parts age naturally and their life should not surpass 6 YEARS. Please replace when necessary.
- When raising the seed drill, the front axle is unloaded. Ensure that the machine has enough load to prevent it overturning. At this time you must ensure that the condition of both the steering and the brakes is optimal.
- During transit with the raised seed drill, block the lowering switch. Before leaving the tractor, lower the seed drill onto the ground and remove the tractor's starting key.
- Always use enough supporting elements when maintaining the machine in a raised position to prevent the machine from lowering or falling.



### 3.4 LOADING AND UNLOADING INSTRUCTIONS

If possible, use a bridge crane to load and unload the truck. Figures 1 and 2 show how and where to place the tow ropes to perform this operation: in the machine's three-point linkage as well as in the fasten points situated in the harrow's support.

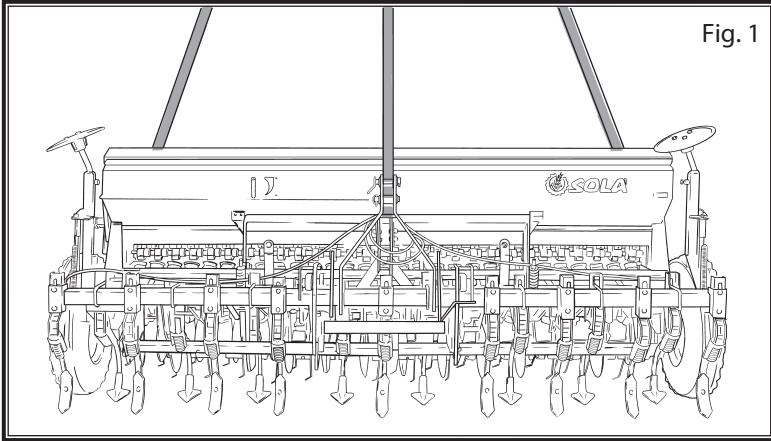

Fig. 1

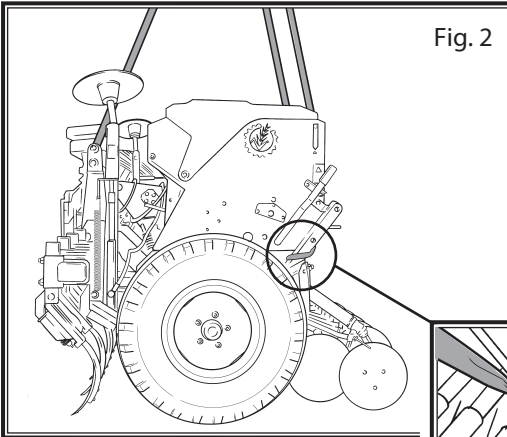
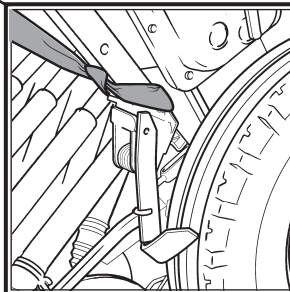

Fig. 2

THESE ARE DANGEROUS TASKS. THEY SHOULD ONLY BE PERFORMED BY QUALIFIED AND EXPERIENCED PERSONNEL.

WHEN THE SEED DRILL IS SUSPENDED, BE SURE THAT THE DANGER ZONE BELOW AND SURROUNDING THE MACHINE IS CLEAR TO PREVENT SERIOUS CONSEQUENCES IN CASE IT FALLS.





## 4-ESSENTIAL SOWING CONCEPTS

### 4.1 TERRAIN

The better the soil condition, the better the sowing quality. Work is more difficult on big clods or uneven furrows.

Although SOLÀ machines resist harsh conditions, if the seedbed does not satisfy appropriate conditions then the sowing quality will suffer.

### 4.2 THE SEED

It is essential that seeds are well maintained and clean. Barley seeds should be trimmed.

### 4.3 SEED PLANTING DEPTH

The recommended seed planting depths are from three to five centimetres. Planting too deep causes problems as rhizome cannot reach the surface and the plant will die. It does not matter that some grains are visible because the harrow's tines will cover them eventually.

The seed planting depth has consequences for tillering, as well as for the plant's strength and its ability to resist frostbite or drought. The parent shoot grows from 1 to 2 cm under the ground, whatever the depth of the seed.

Planting deeper does not necessarily mean getting deeper roots. Only a few roots grow from the lower part of the seed. Most of them grow from a parent shoot close to ground level.

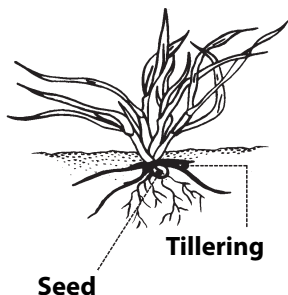

Fig. 3.1

**Normal Planting Depth: from 2 to 4 cm (Fig. 3.1)**

- Thick stem, short rhizome, resistant to frostbite
- Multiple tillering providing from 3 to 6 shoots and a lot of blades, from 6 to 10.
- Deep and thick roots, approximately 5 cm in width and 10-12 cm in depth.
- With less grains per sowing square metre, more ears are obtained.

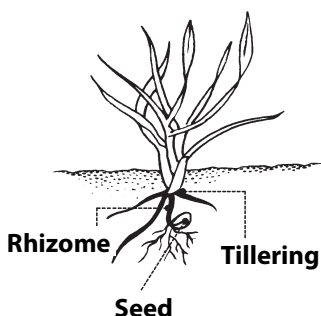

Fig. 3.2

**Deeper Planting: from 5 to 6 cm (Fig. 3.2)**

- Fine stem, rhizome exposed to frostbite.
- Late and weak tillering, 1 or zero shoots and only a few blades, 3-4 approx.
- Medium quality roots of approximately 3 cm in width and 5 cm in depth
- More grains per sowing square metre are required to obtain the same number of ears as in the previous case.

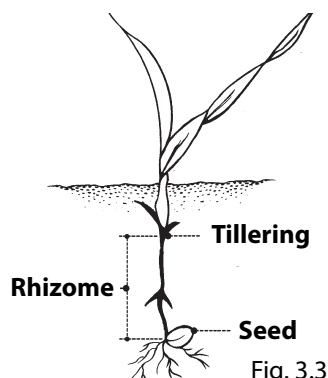

Fig. 3.3

**Very deep planting: from 8 to 10 cm (Fig. 3.3)**

- Very fine stem. No tillering and only one blade.
- Seed runs out of supplies by growing a long rhizome which frostbite can easily cut.
- The plant takes weak roots, approximately 1 cm in width and 3 cm in depth.
- Twice the number of grains per sowing metre are required to obtain the same number of ears as in the first case.

**WARNING:**

IN VERY COLD PLACES, REPEATED FROSTBITE CAN HAVE A HONEYCOMB EFFECT ON THE GROUND'S MOST SUPERFICIAL LAYER. IN THIS CASE THE PLANT'S VERY FIRST ROOTS CAN LOOSEN AND THE PLANT WILL DIE. SLIGHTLY DEEPER PLANTING IS RECOMMENDED AND IF POSSIBLE, THE USE OF ROLLERS TO COMPACT THE EARTH TO BETTER PROTECT THE SEEDS.

**WARNING:**

IN ALL SOLÀ MACHINES, THE RIGHT SIDE WHEEL ACTIVATES THE SEED WHEEL'S MECHANICAL TRANSMISSION. CONSEQUENTLY, SHARP CURVES SHOULD BE PERFORMED TOWARDS THE LEFT SIDE, SINCE USING THE GROUND WHEEL DRIVE WOULD CAUSE A LESSER SEED DISTRIBUTION.

**WARNING:**

WHEN STARTING THE MACHINE, FURROWS WILL NOT CONTAIN ANY SEEDS FOR A METRE.

WHEN STOPPING THE MACHINE, SEEDS WHICH WERE PREVIOUSLY INSIDE THE SEED HOSES, SLIDE FROM THE MACHINE AND END UP PILED ON THE GROUND.

TAKE THIS INTO ACCOUNT WHEN STOPPING AND STARTING THE MACHINE IN ORDER TO ACHIEVE MORE ACCURACY.

**WARNING:**

ALWAYS WORK AT A UNIFORM SPEED AS SUDDEN ACCELERATING AND SLOWING DOWN WILL CAUSE AN IRREGULAR SEED DISTRIBUTION.



## 5. STARTING

### 5.1 COUPLING

Seed drill ED-1003 is fitted for fast coupling to the hydraulic lift. The oscillating coupling bar adapts to ground's irregularities. In order to switch it off, place the machine in a raised position and unlock the two locking hooks (1, fig 4) to secure the hooked clip (2, fig 4) of the lever's (3, fig 4) to the axis (4, fig 4).

Seed drills with integrated cultivators are provided each with a bar that has two elbows (5, fig. 4). These elbows allow the cultivator's tines to move without increasing the distance between the seed drill and the tractor. When coupling the seed drill to the tractor, the rod (6, fig. 4) will lean on the arm of the tractor's three-point linkage.

ALL MACHINES WITHOUT CULTIVATORS ARE SUPPLIED WITH A SUPPORTING BASE TO SECURE THE MACHINE DURING TRANSPORTATION AND PREVENT ACCIDENTS. THIS MUST BE REMOVED BEFORE WORKING WITH THE MACHINE.

When the arms of the tractor's three-point linkage are too short, the AUTOMATIC COUPLING needs to be used in order to increase by 12 cm the distance between the seed drill and the tractor.

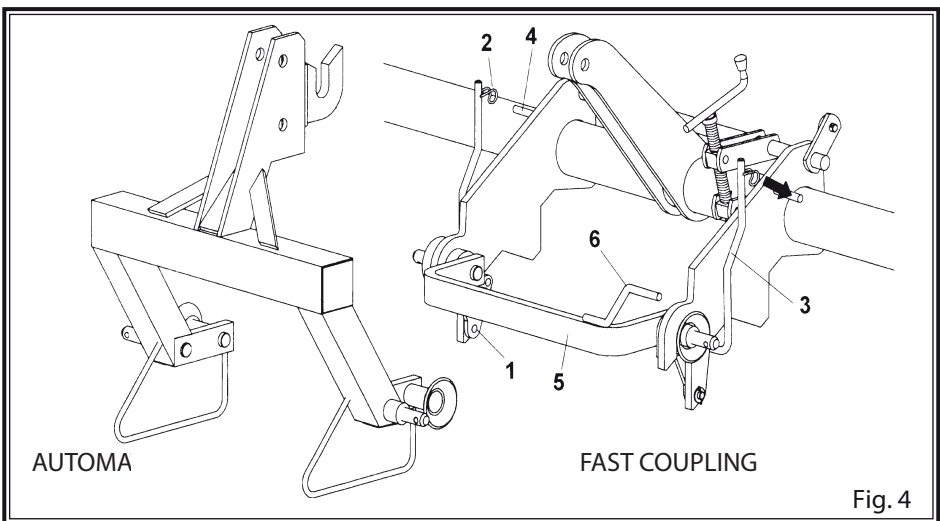

**PLEASE NOTE:**

MAKE SURE THAT NOBODY IS EVER BETWEEN THE SEED DRILL AND THE TRACTOR WHEN COUPLING BOTH MACHINES.

## 5.2 DOSING SYSTEM

SOLA's dosing system can be adjusted to the following working positions:

- Narrow position with small housings, used for small seeds (fig. 5).
- Wide position with large alternated housings, used for regular or big seeds (figs. 6 and 7).

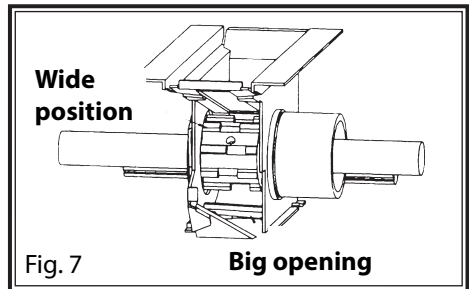
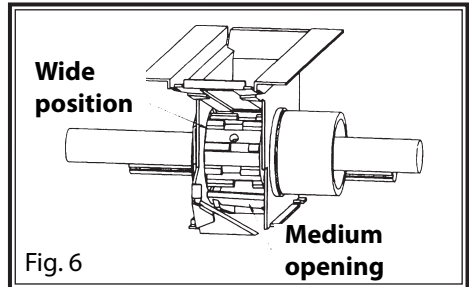
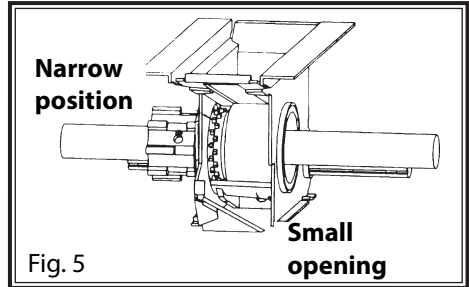

Opening used for emptying

Base flap performs two roles:

- It adjusts its opening to adapt to the seed's size. (figs. 5, 6 and 7).
- It empties the hopper into the calibration cup (fig. 8).

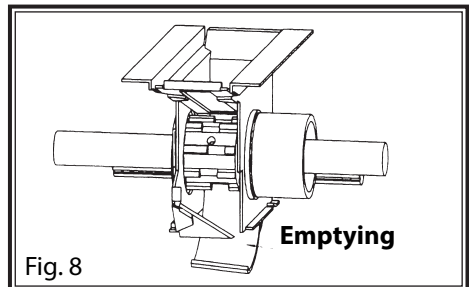



**WARNING:**

IN ORDER TO SWITCH FROM THE WIDE TO NARROW POSITION, THE SEED WHEELS DOSING MUST BE FREE FROM SEEDS. IF NOT, TURNING THE SEED WHEEL WILL BE MORE DIFFICULT.

Once the position is chosen (narrow or wide) and the base flap is adjusted (depending on the seed's size), the seed flow to be dosed will depend on seed wheel's speed. The gearbox allows the user to precisely adjust the seed wheel's speed to sow from 0 to 600 kg/ha.

### 5.3 SEED DOSING

Check that the shutoff gates are open and allow the seed flow. Before filling the hopper, check that there are no external elements inside the hopper and then connect the agitator's shaft to the gearbox's axle.

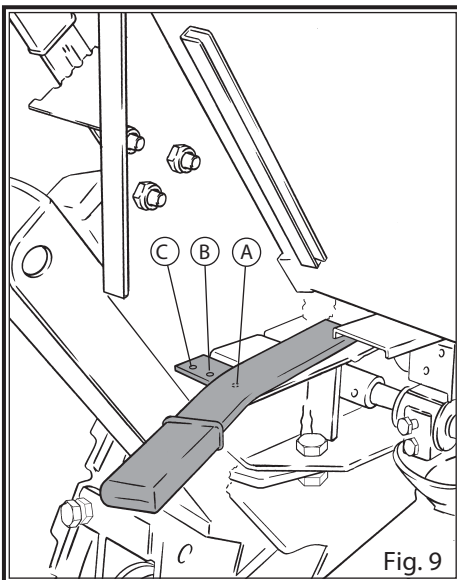

Move the lever to switch between the narrow and wide position in the seed wheel (fig. 9):

A. To the right, to set wide position for wheat, barley, etc.

B. To the centre, to set medium position for sunflowers, peas, etc.

C. To left, to set narrow position for lucerne, rape, etc.

The base flap lever (placed on the left side of the hopper) has 7 positions (fig. 10):

No 1, for fine seeds.

No 3, for wheat and barley.

No 5, for big seeds.

To empty the hopper, place the calibration cup under the seed wheels and move the lever beyond position n° 7 (emptying position).

Finally loosen the gearbox's knob, move the gear lever on the sector graduated from 0 to 100 and tighten the knob to the position previously selected (fig. 11), as indicated in the dosing tables.

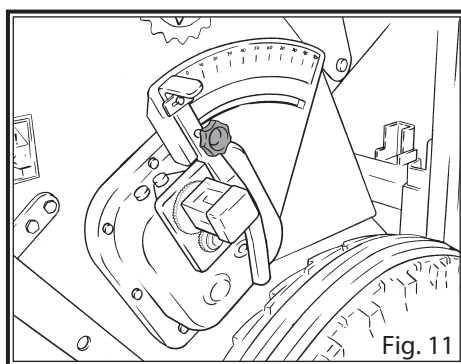
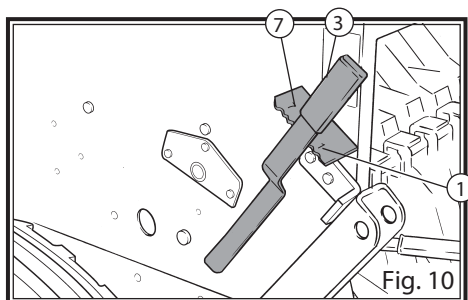

## 5.4 CALIBRATION TEST

Once the narrow or wide position is selected, and both the base flap and the gear lever are in the correct position, it is essential to perform a calibration test.

**FIRST:** Withdraw the spring-loaded lever (2, fig. 12) that keeps the funnel-carrying bar in working position and push the bar (1, fig 12) forward until the end. This will allow the calibration cup to be placed under the seed wheels.

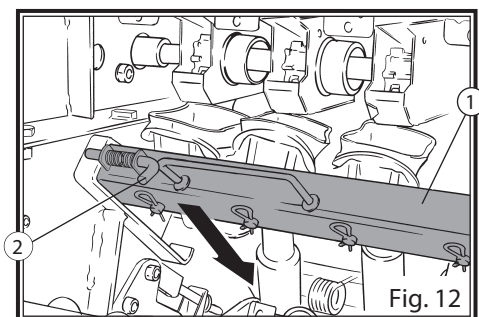

**SECOND:** Pull the calibration cup (3, fig. 13) upwards out of the holders (4, fig. 13) and place it under the seed wheels.

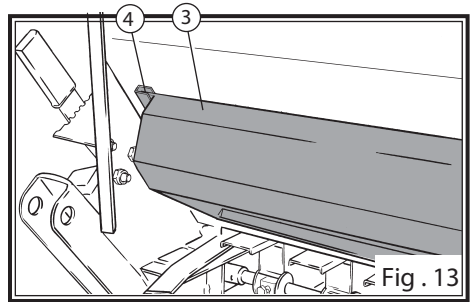

Fig . 13

**THIRD:** Raise the seed drill using the tractor until the wheels can turn freely. Place the calibration crank (1, fig. 14) in the bolt on right wheel (2, fig. 14) and turn it clockwise until seeds start to fall onto the calibration cup . At this moment, stop turning, put these seeds back inside the hopper and start turning the crank again to perform the real turns of the test.

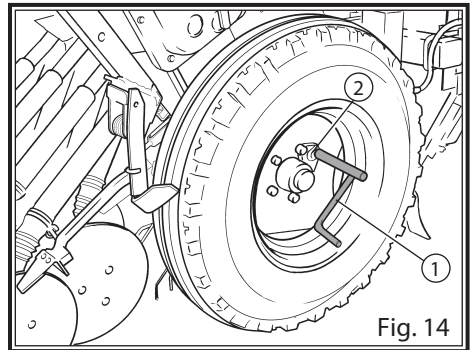

Fig. 14

TYPE	TYRE 6.00-19	TYRE 7.50-16
250	40 turns	
300	33 turns	35 turns
350	28,5 turns	30 turns
400		26 turns

You must turn the wheel uniformly using the crank at approximately one revolution per second, depending on the land's characteristics, tyre's manufacturer or tyre pressure. For this reason it is highly recommended to perform a field test as described in this manual.

At the end, accurately weigh the collected seeds that are in the calibration cup. At a selected opening, you can obtain the kilograms per hectare distributed by the machine, by multiplying the weight by 40.

For ease of performing these operations the machine should be coupled to the tractor in a slightly elevated position (wheels should not be in contact with the ground). It is also necessary that the hopper is only half-filled with seeds to alleviate difficulty in turning the wheel with the crank.

If seeds show excess treatment powder, flow can be reduced, consequently a second control is recommended after sowing approximately three hoppers.



**PRECAUTION:**

IT IS DANGEROUS TO TURN THE WHEEL WITH YOUR HANDS AS THE MUD SCRAPER CAN CAUSE INJURIES.

## 5.5 FIELD TEST

If differences exist between the test and the actual dose distribution (due to a very uneven or light soil, low pressurised tyres, etc.), an experimental test can be performed.

First of all, the distance (in metres) as shown in the table below should be marked on the field's ground using a tape measure.

MACHINE TYPE	METRES TO COVER
250/14	100,0
300/17	83,3
350/19	71,4
400/22	62,5

Next, the seed drill in working position should cover that distance.

By means of a mark made previously on the tyre, count the number of turns performed in the covered distance. A good place whereby which to count could be the wheel's mud scraper.

By following these steps we can obtain the actual number of turns performed in the seed dosing test. By performing the test, we will know the actual kilograms per hectare distributed by the machine.

## 5.6 SEED DOSING ADJUSTMENTS

When using high quality certified seeds it is not enough to know the weight in kilograms distributed by the machine, as the final result of the harvest will depend on the number of plants which eventually ripen.

Every plant requires a certain amount of land from which nutrients will be absorbed. Therefore, both a low or an excessive plant density can be detrimental. To determine how many kilograms per hectare are to be sown, you should know the number of plants per square metre that are going to be planted.

As a guidance, the recommended number of plants per square metre when sowing wheat or barley in un-irrigated land can be found in following table:

### **AUTUMN:**

Premature sowing, 200 plants per m<sup>2</sup>

Late sowing: 265 plants per m<sup>2</sup>

### **SPRING:**

Premature sowing, 310 plants per m<sup>2</sup>

Late sowing: 445 plants per m<sup>2</sup>

Please note that in spring there is less tillering so more seeds should be sown.



### **WARNING:**

MAQUINARIA AGRÍCOLA SOLÁ, S.L. RECOMMENDS THAT THE FARMER SEEKS PROFESSIONAL ADVICE ABOUT THIS SUBJECT FROM A TECHNICAL SOWING CENTRE.



### **WARNING:**

SEED DOSING SHOULD BE ADJUSTED TO EACH TERRAIN, DEPENDING ON THE: TEXTURE, FERTILIZING LEVEL, PLUVIOMETER RESULTS AND SOWING SEASON, GRAIN QUALITY, GERMINATING AND TILLERING POWER, ETC.

It should be taken into account that a seed's germinating power is variable and dependant on multiple factors. It can be experimentally calculated to be between 70% and 80%, which is practically equivalent to multiplying the number of grains to be sown by 1,43 or 1,25 respectively.

Next, we describe a practical method to determine the number of kilos per hectare to be distributed once we know how many plants per square metre we want to obtain.

1) Place seeds on the "seed counter" (fig. 15)

Wipe seed counter with your hand to make sure that there is only one grain per slot (100 grains in total). Do the same 10 more times to obtain 1000 grains.

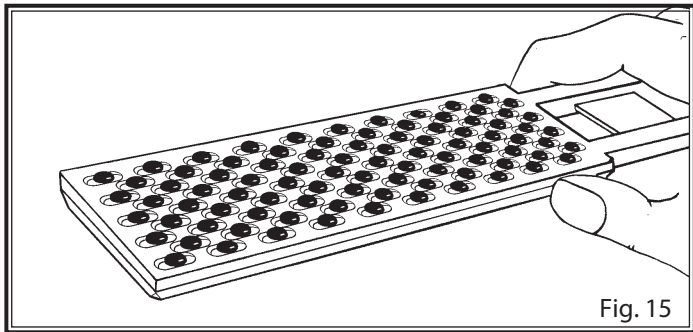

2) Weigh 1000 grains with the precision scales. We call the result the OPERATIVE WEIGHT.

3) Once we know how many seeds per square metre we are going to sow, we should adjust the following kilograms per hectare in the dosing control:

**kilograms per hectare = (grains per m<sup>2</sup> x OPERATIVE WEIGHT) / 100**

## 5.7 DOSING SYSTEM IN COMBINED SEED DRILLS (SEEDS AND FERTILIZER)

Dosing system in combined seed drills has a double inox casing. The seed wheels and the base flap are made of a special plastic to prevent wear and tear.

The seed wheel has both narrow and wide positions, however on the other hand the fertilizer wheel has a constant flow. The last one is assembled on an hexagonal axle to be easily taken apart without tools.

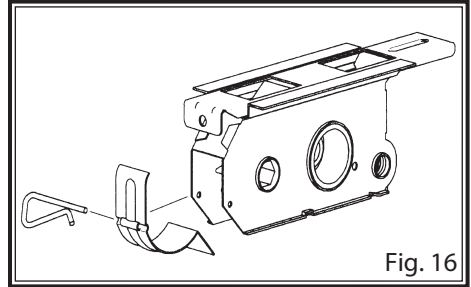

The fertilizer's base flap is a stainless steel lid, which can be taken apart using a clip. This way, it can be cleaned it easily (fig. 16).

## 5.8 DOUBLE HOPPERS IN COMBINED SEED DRILLS

The combined hopper is divided in two compartments, the rear one for the seeds (1, fig. 27) and the front one for the fertilizer (2, fig. 17). The latter is provided with a plate with holes (3, fig. 17) to sieve stones and clods which could damage the dosing system.

Each compartment has separate controls to adjust seed and fertilizer dosing independently.

The fertilizer compartment has a metallic folding lid to prevent the fertilizer overflowing from the hopper when this it is being filled.

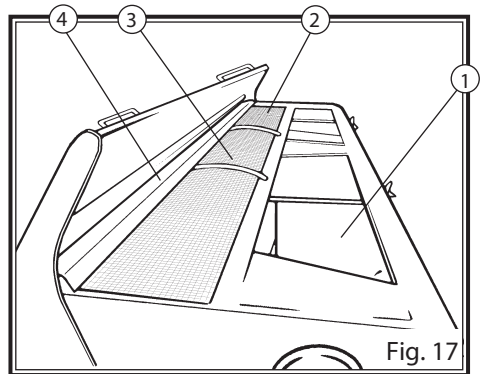

## 5.9 FERTILIZER DOSING IN COMBINED SEED DRILLS

In combined seed drills, dosing and calibration tests are exactly the same as in regular seed drills.

Fertilizer dosing is performed using the gearbox placed on the left part of the machine (fig. 18): loosen the gearbox's knob, move the gear lever on the sector graduated from 0 to 50 and tighten the knob to the position previously selected, as indicated in the fertilizer dosing table.

The dosing table is for guidance only, as the fertilizer's density can vary significantly depending on the manufacturer's production method. For this reason, SOLÁ recommends performing a previous fertilizer calibration test, similar to the one formerly performed on the seeds:

**FIRST:** Withdraw the spring-loaded lever (2, fig. 19) that keeps the funnel-carrying bar in working position and push the bar (1, fig 19) forward until the end. This will allow the calibration cup to be placed under the seed wheels.

**SECOND:** Pull the calibration cup (3, fig. 20) upwards out of the holder (4, fig. 20) and place it under the fertilizer wheels.

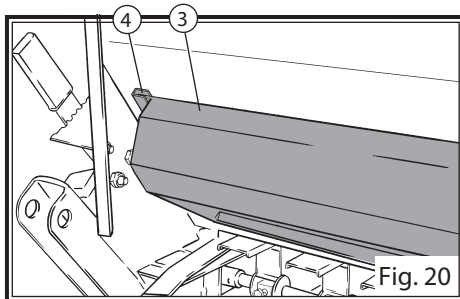
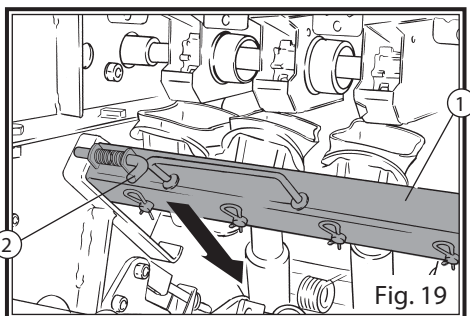
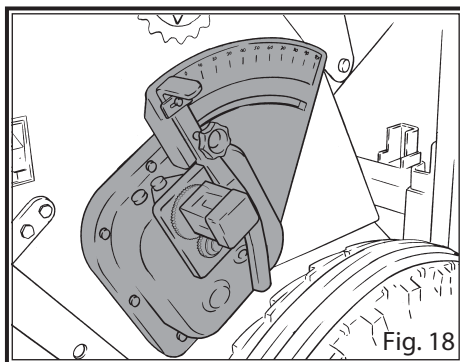



**THIRD:** Raise the seed drill using the tractor until the wheels can turn freely. Place the calibration crank (5, fig. 21) in the bolt on right wheel (6, fig. 21) and turn it clockwise until the fertilizer starts to fall onto the calibration cup. At this moment, stop turning, remove this fertilizer and start turning the crank again to perform the real turns of the test as indicated in the table below:

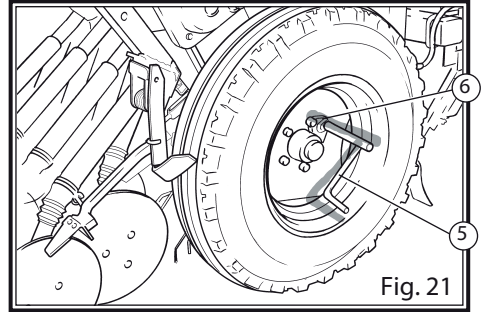

Fig. 21

TYPE	TYRES 6.00-19	TYRES 7.50-16
250	40 turns	
300	33 turns	35 turns
350		30 turns
400		26 turns

At the end, accurately weigh the calibration cup. At a selected value of the graduated sector, you can obtain the kilograms per hectare of fertilizer distributed by the machine, by multiplying the weight by 40.

It is recommended to perform a precision test on the fertilizer to be used, in order to check the reliability of the table in page 38.

**PRECAUTION:**

IT IS DANGEROUS TO TURN THE WHEEL WITH YOUR HANDS AS THE MUD SCRAPER CAN CAUSE INJURIES.

**WARNING:**

SOLÁ RECOMMENDS FREQUENTLY CLEANING THE CIRCUIT FORMED BY FUNNELS, HOSES AND SOWING SHOES.

## 5.10 HOPPER LEVELLING AND DISC COULTER'S ADJUSTMENTS

The hopper must be in a level position so that the seed drill can work properly. For this purpose, make sure the moving arrow coincides with the mark on the hopper (1, fig. 22) by adjusting the tractor's three-point hydraulic system.

When starting to work, the discs are lowered to their maximum depth using the adjusting spindle (1, fig. 23) and should stay in this position as shown in the figure.

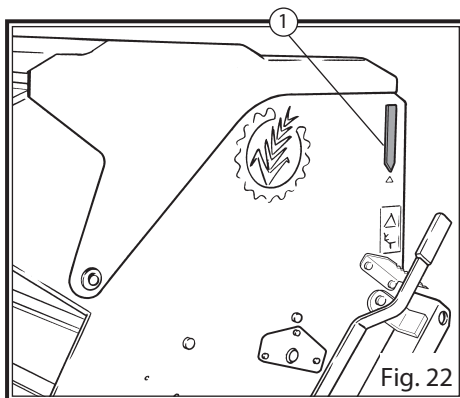

Next, operate the central adjusting spindle that adjusts the pressure of each disc coulters' springs. This will gradually increase the working pressure that the disc coulters exert onto the ground according to the requirements of the work circumstances.

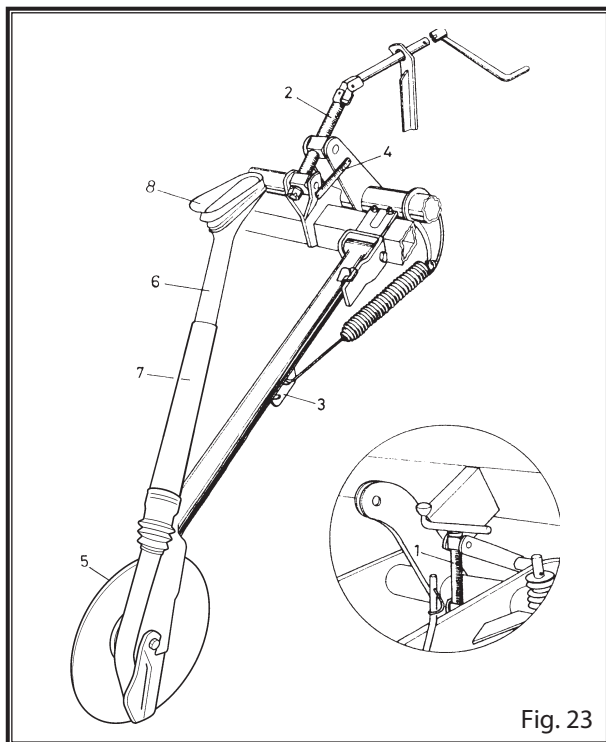

As a general rule, depth level of the seed depends on the ground's texture as well as the pressure performed by the discs, provided that the discs adapt correctly to the irregularities of the terrain. This will happen if the spindle (1, fig. 23) is totally extended and both the cultivator and the leveller work properly.

Seed drill of type 250 is equipped with a central adjusting spindle (2, fig. 23). However, the machine types 300, 350 and 400 have two spring-loaded bar in order to reduce the effort, so two spindles must be operated to adjust the disc coulter's pressure. A graduated scale (4, fig. 23) in each spindle acts as a guide to make both pressures equal.

The telescopic seed hoses can be disconnected matching the exterior slot in the small tube (6, fig. 23) with the inner slot in the big tube (7, fig. 23).

The upper part of the telescopic seed hoses has a funnel (8, fig. 23) which collects the small seeds and prevents rebounds of the heavy seeds (peas, chickpeas).

**WARNING:**

IN RARE OCASIONS, WHEN SOWING LUCERNE SEEDS (WHICH SHOULD BE SOWN VERY SHALLOWLY) ON A VERY SOFT GROUND, IT IS RECOMMENDED TO NOT TO LOWER THE DISCS COMPLETELY AND NOT PRESURISE THE SPRINGS TO PREVENT EXCESSIVELY DEEP SOWING.

**PLEASE NOTE:**

SOLÁ RECOMMENDS, WHEN SOWING LUCERNE SEEDS, FREQUENTLY CLEANING THE SEED WHEELS TO PREVENT THE PROGRESSIVE HARDENING OF THE WASHERS OF EACH SEED WHEEL.

## 6 – ACCESSORIES

### 6.1 CULTIVATOR

The cultivator can shift vertically keeping its parallelogramic shape, without changing the tine couler's penetration angle. To shift it, operate the spindles (1, fig. 24) placed in the sides of the seed drill. Each spindle has a telescopic protective cover against the dust (2, fig. 24).

Each spindle also has a graduated scale to make the cultivator's and the seed drill's height even (3, fig. 24).

Each tine couler can be moved:

- a) Horizontally along the chassis's bar.
- b) Vertically to provide more depth to the tine coulers which coincide with the tractor's wheels or to raise the central tine coulers if they turn over too much earth.

Tine coulers can be added or removed as desired. They can also be moved along the bar to get a different spacing. Sometimes it is recommended to equip front tine coulers with the same blade type as the cultivator's second row to better turn over the earth that contains weeds. To stop the work of the cultivator, it is enough to raise the bar to the highest position.

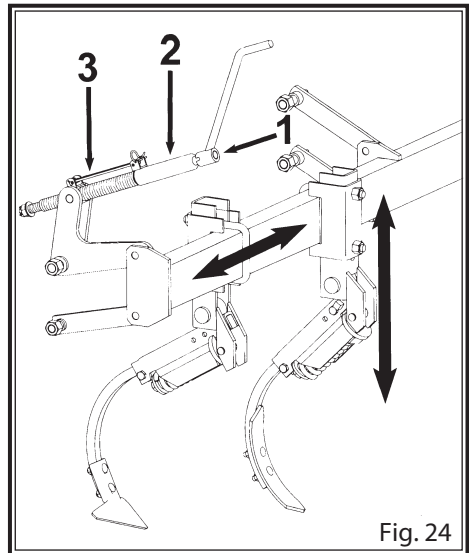

Fig. 24



#### ATTENTION:

IF THE ASSEMBLING ARRANGEMENT OF THE CULTIVATOR IS MODIFIED, BE CAREFUL: WHEN THE EARTH CONTAIN STONES, THE TINE COULERS SHOULD BE ABLE TO ARTICULATE BACKWARDS FREELY. OTHERWISE, THE TINE COULERS AND SUPPORTS COULD BE DAMAGED.

## 6.2 LEVELLER

The leveller is divided in two halves to adapt to the terrain's irregularities. Each half has a spindle with a spring to adjust its height and working pressure (1, fig. 25). The spring allows the spindle to overcome stones or other obstacles and to level evenly .

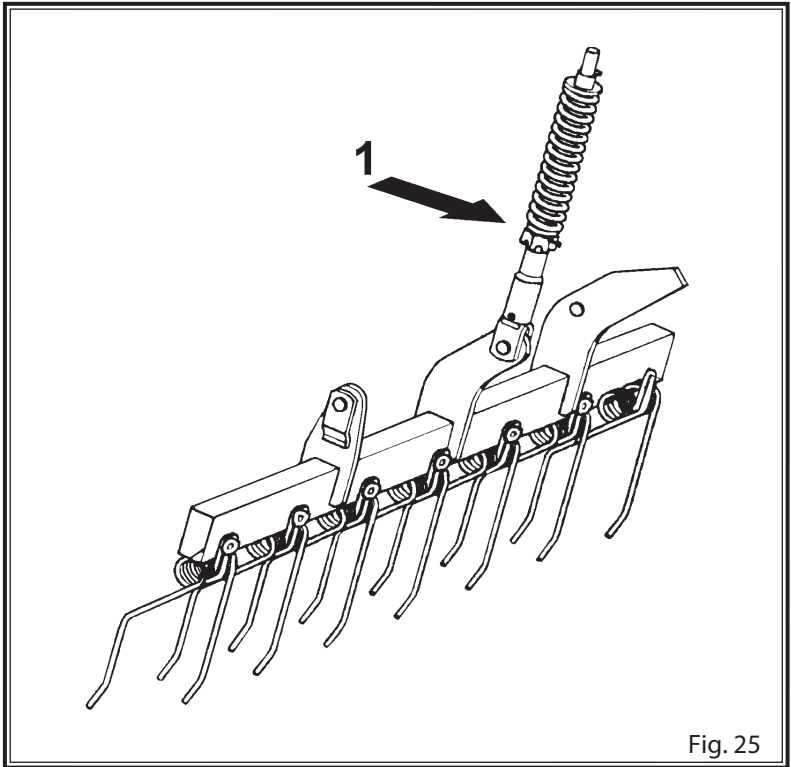

Fig. 25

A balanced use of the cultivator and leveller according to the characteristics of the ground, provide an excellent seedbed.

Please note that before using the seed drill with the cultivator and the leveller, the land should be tilled.

## 6.3 WHEEL SCRAPERS

The wheel scrapers are adjusted by means of a screw placed in the upper part of the scraping arm.

Sometimes, when raising the seed drill while the tractor is running, the wheels keep turning and seeds keep falling to the ground, unnecessarily.

To stop this, operate the blocking screw of the scraper until the screw makes contact with the wheel. This slight brake is enough to prevent the inertial turning of the wheels.

### **BLOCKING:**

In wet and clay like grounds, we encourage blocking the scrapers by turning the joint of the torsion springs.

For this purpose, place a screw where the drill hole of the scraper and its support meet.

## 6.4 HARROW WITH FLEXIBLE TINES, MODEL EPI-6

Seed drill ED-1003 is equipped with a harrow with double-tine springs (3, fig. 26) which contribute to cover back the furrows produced by the sowing tine coulters.

By using the upper nut (1, fig. 26), the harrow's working pressure can be adjusted.

To adjust working depth, use the lower nut (2, fig. 26).

The parallelogram-shaped joint allows the flexible tines to adapt vertically and horizontally to terrain irregularities.

Always use original double-tine springs from SOLÀ, as they have been rigorously tested to achieve the highest quality.

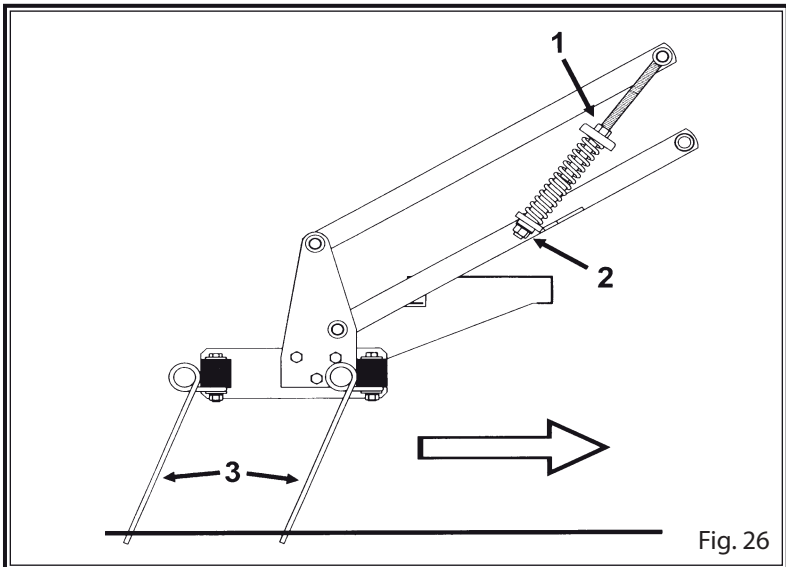

**PRECAUTION:**  
NEVER STEP UP THE HARROW WHEN THE MACHINE IS RUNNING.

## 6.5 TRACK MARKERS

Track markers should be assembled using the supplied screws in the supports placed in both sides of the machine.

They are hydraulic and should be connected to a double-acting connection so that one arm is in vertical position and the other one is in working position.

Cylinders contain a throttle to slow down and smooth the track marker's lift. Before starting work, check that they are in working order.

Track markers also have an extra spring which allows to adjust the pressure that track discs perform on the ground.

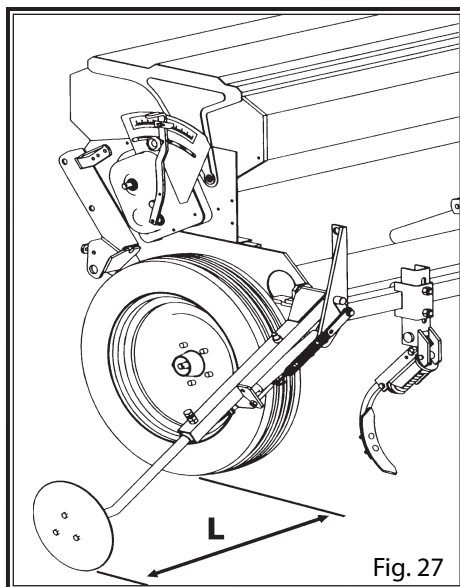

To calculate the horizontal spacing between track discs and the last lateral tine coulter (L, fig. 27), use following formula:

$$L = (\text{Working width of the seed drill} - \text{track width of the tractor} + \text{row spacing}) / 2$$



**PRECAUTION:**

HIGH PRESSURE OIL MAY ESCAPE, PASS THROUGH THE SKIN AND INGRESS INTO THE BODY, CAUSING SERIOUS INJURIES. KEEP HYDRAULIC HOSE LINES IN GOOD CONDITION.

NEVER STAND UNDER THE TRACK DISCS OR WITHIN THEIR OPERATIONAL AREA.

In order to transport the machine, it is essential to fold the track markers so they stay in a vertical position and pin them to the transport bracket using a lynch pin. This will prevent them from lowering during transit (fig. 28).

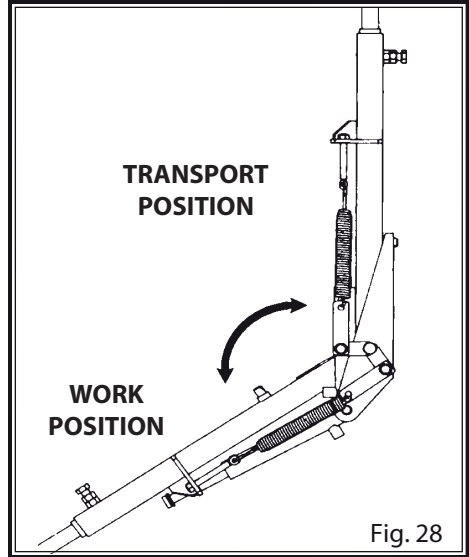
**WARNING:**

WHEN PULLING THE HYDRAULIC PIPES, BE SURE THAT THEY CAN NOT BE DAMAGED WHEN RAISING OR LOWERING THE SEED DRILL. CHECK ALSO THAT THEY ARE NOT EXPOSED TO ANY FRICTION.

DO NOT ADJUST SPRINGS AT HIGH PRESSURE NOR ORIENTATE TRACK DISCS VERY OBLIQUELY TO PREVENT SERIOUS DAMAGES TO THEM.

### 6.5.2 MECHANICAL TRACK MARKERS

They are assembled to the sides of the machine, as are the hydraulic ones. The control lever (C, fig. 30) assembled to the three-point linkage (D, fig. 30) controls with wires (A, B, fig. 30) the alternate raising and lowering of the track discs (C, fig. 30).

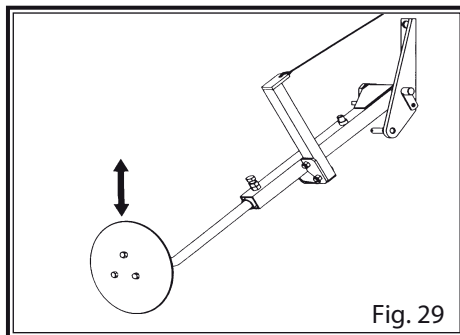

Fig. 29

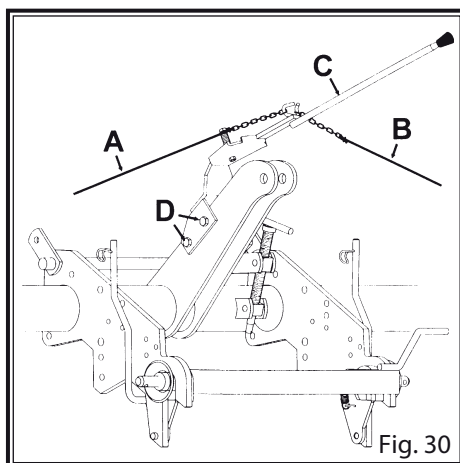

Fig. 30

### 6.6 HECTARE COUNTER

The screw placed in gearbox's upper part must be removed (fig. 31). Next, the hectare counter must be assembled over the gearbox's axle (A, fig. 31) and the special screw (B, fig. 31) supplied with the hectare counter must be screwed down in place (fig. 31).

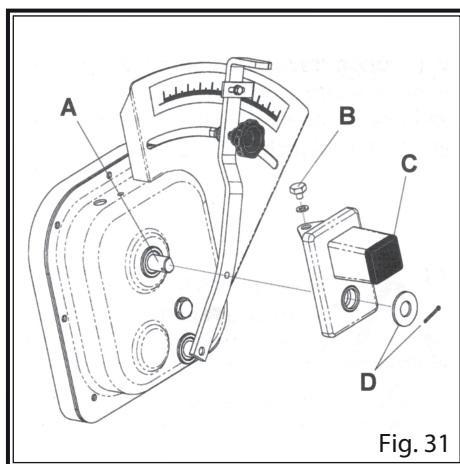

Fig. 31

To access to the hectare counter's reset control, remove the black lid (C, fig. 31).

Finally, a washer and a pin should be placed at the end of the gearbox's axle (D, fig. 31). It is important to check that the pin is not in contact with the hectare counter's box when turning.

Hectare counter "SOLÀ 90" is a direct reading type (hectares and squared metres) and both pinion gears are specific for each machine type, as indicated in the following table:

MACHINE	DRIVE PINION	DRIVEN PINION
250	Z-30	Z-63
300	Z-34	Z-59
350	Z-36	Z-57
400	Z-39	Z-54



**WARNING:**

IF THE HECTARE COUNTER IS SUPPLIED SEPARATELY FROM THE MACHINE, IT IS ADVISABLE TO CHECK THAT PINION TYPE IS CORRECT.



## 7 – MAINTENANCE

### 7.1 LUBRICATION

The following parts should be lubricated periodically:

Wheels bushings, releasing the push-in cap. Use solid calcium grease (1, fig. 32)

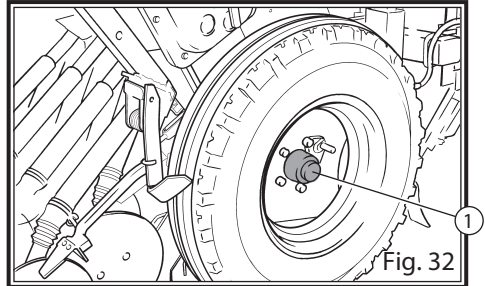

Fig. 32

The seed dosing lever's roller guide (2, fig. 33). Use solid calcium grease.

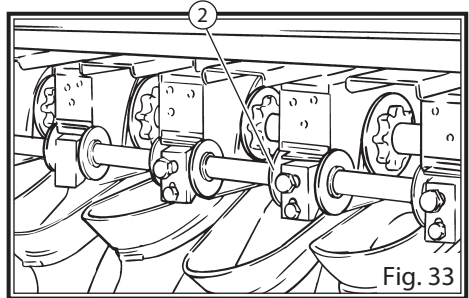

Fig. 33

The central adjuster spindle. Use solid calcium grease (3, fig. 34)

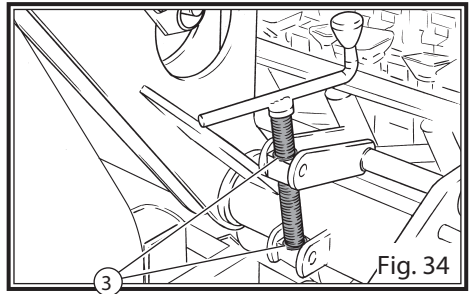
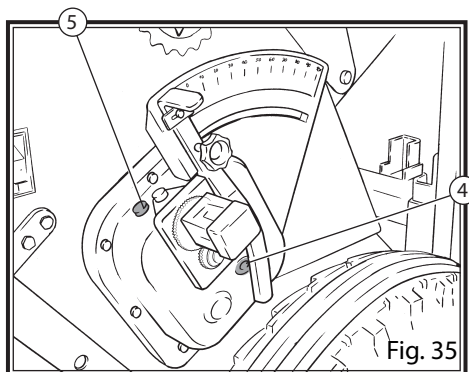

Fig. 34

Check the gearbox's oil level by using the peephole (4, fig. 35). If necessary, remove the cap (5, fig. 35) and refill it with oil type SAE 30.



**WARNING:**  
NEVER LUBRICATE THE SEED WHEELS.

## 7.2 TYRE PRESSURE

Indicated pressures are provided by the manufacturer, at maximum load.

Tyres 6.00-19----- 3,75 kg/cm<sup>2</sup>

Tyres 7.50-16----- 3,75 kg/cm<sup>2</sup>

In general use and especially when working on irregularly tilled terrains, it is recommended to use a slightly lower pressure to absorb the ground's irregularities and get a higher regularity in sowing.

## 7.3 SCREWS

After working for some hours, all screws subjected to stress should be checked and tightened, as well as the studs of the mobile parts.

SOLÁ recommends proceeding by groups:

1. Coupling point and joints of the cultivator's tine coulters.
2. Leveller and its spindles.
3. Disc coulters and their coupling point to the chassis.
4. Securing points of the hopper to the chassis.
5. Wheels stud bolts.

## 7.4 ANTI-RUST CONTROL (COMBINED MACHINE)

Once the sowing season is over, a complete check should be performed on the machine. For this purpose, SOLÁ recommends:

- a) Taking apart the telescopic seed hoses with their funnels and sleeves. Take apart the seed wheel lids.
- b) Cleaning the machine with high-pressure water, especially the inside of the hopper and the double seed-fertilizer wheels which, without their lids, are perfectly accessible. Move the wheels so the seed wheels turn and the water reaches everywhere.
- c) Repainting those parts which show any sign of rust, specially the hopper and its cover.
- d) Checking all parts that will need greasing.





## 8 - DOSAGE TABLES



**WARNING:**

INDICATED QUANTITIES SHOWN IN THE FOLLOWING TABLES SHOULD BE CONSIDERED FOR GUIDANCE ONLY, FORESEEN FLOWS CAN VARY DEPENDING ON THE ACCIDENTAL PRESENCE OF DISINFECTING PRODUCTS, UNEVEN SEED SIZE, DENSITY, HUMIDITY, ETC.



**WARNING:**

FOR PRECISION SOWING, FOLLOW DOSING PROCESS DESCRIBED IN SECTION 6 OF THIS MANUAL.



**WARNING:**

AS A GENERAL RULE, SMALL GRAINS NEED SMALLER OPENINGS THAN LARGER ONES, ROUND GRAINS NEEDS SMALLER OPENINGS THAN LONGER ONES, AND LIGHT GRAINS NEEDS BIGGER OPENING THAN HEAVIER ONES.

## 8.1 SEED DOSAGE TABLE (KG/HA)

NUMBER IN THE GRADUATED SECTOR	WHEAT	BARLEY	TRITICALE	PEAS	BEANS	RAPE
POSITION	WIDE	WIDE	WIDE	WIDE	WIDE	NARROW
14					73	3.5
16					88	4.8
18					106	5.6
20	82	64	61	41	126	6.6
22	91	73	68	47	140	7.9
24	100	80	75	50	155	8.8
26	109	88	81	56	175	9.9
28	118	96	89	61	194	10.1
30	128	107	87	67	210	12.8
32	138	115	107	70	227	14.0
34	147	123	116	75	244	15.5
36	157	132	127	80	261	17.0
38	165	139	135	84		18.7
40	173	146	143	88		20.7
45	192	162	158	94		22.6
50	213	180	173	100		25.5
55	233	198	189	106		
60	254	217	207	114		
65	276	233	224	140		
70	297	251	240	151		
75	318	270	257	160		
80	339	286	274			
85	364	303	291			
90	391	318	307			
95	404	336	324			
ROW SPACING	12 cm	12 cm	12 cm	24 cm	12 cm	24 cm
BASE FLAP'S LEVER	3	3	3	5	4	1
OPERATIVE WEIGHT OF 1000 GRAINS	40 g	46 g	30 g	293 g	530 g	--

SAINFOIN	VETCHES	RAY-GRASS	LUCERNE	SPINACH	FLAX	OATS
WIDE	WIDE	NARROW	NARROW	NARROW	WIDE	WIDE
22	69		12,6	5,3	35	21,5
27	84		15,3	6,4	42	25,4
31	101		18,5	8,1	49	29,0
36	118		20,7	9,6	56	33,0
40	135		23,8	11,3	63	37,0
46	149		26,0	12,8	70	41,0
50	164	9,4	28,7	14,2	77	45,0
56	185	10,3	32,0	15,9	84	49,0
62	204	11,5	34,8	17,5	91	52,6
70	214	12,7	37,7	19,0	98	56,4
76	236	13,9	41,0	20,6	105	60,0
86		15,0	44,0	22,0	112	64,0
92		16,5	48,0	23,0	126	68,0
96		17,0	53,0	28,0	144	72,0
107		18,5	59,0	31,0	161	82,0
		20,0	64,0	36,0	179	91,4
		22,0	68,0	42,0	196	101,0
		24,0	73,0			111,0
		29,0				120,5
		33,0				130,0
		42,0				149,6
						169,0
						171,6
12 cm	12 cm	12 cm	12 cm	12 cm	12 cm	12 cm
3	2	1	1	1	1	3
19 g	44 g	--	--	12 g	5,6 g	24 g

## 8.2 FERTILIZER DOSAGE TABLE

Fertilizer dosage (kg/ha)

Number in the graduated sector	Fertilizer
0	-
2	42
5	104
7	146
10	208
12	250
15	312,5
17	354
20	416,5
22	458
25	521
27	562,5
30	625
32	666,5
35	729
37	771
40	833
42	858
45	895
47	919
50	956

Rows spacing: 12 cm

Values calculated using wheels 6.00-19 and fertilizer NPK 15-15-15.

Combined machines admit only granulated fertilizer.



**WARNING:**

IT IS RECOMMENDED TO USE HIGHLY CONCENTRATED FERTILIZERS. OTHERWISE THE FERTILIZER HOPPER'S CAPACITY WILL NOT BE IN BALANCE WITH THE SEED HOPPER'S CAPACITY.

## 9– SPARE PARTS

### 9.1 - INTRODUCTION:

The terms RIGHT, LEFT, FRONT and REAR refer to the machine in its starting direction (fig. 36).

When guidance describes parts that have a matching pair (symetrical handles, wheels etc) only one will be demonstrated in the drawings shown. Please search for the distinguishing reference in the spare parts list.

The number and type of the machine can be found on the machine's IDENTIFICATION PLATE.

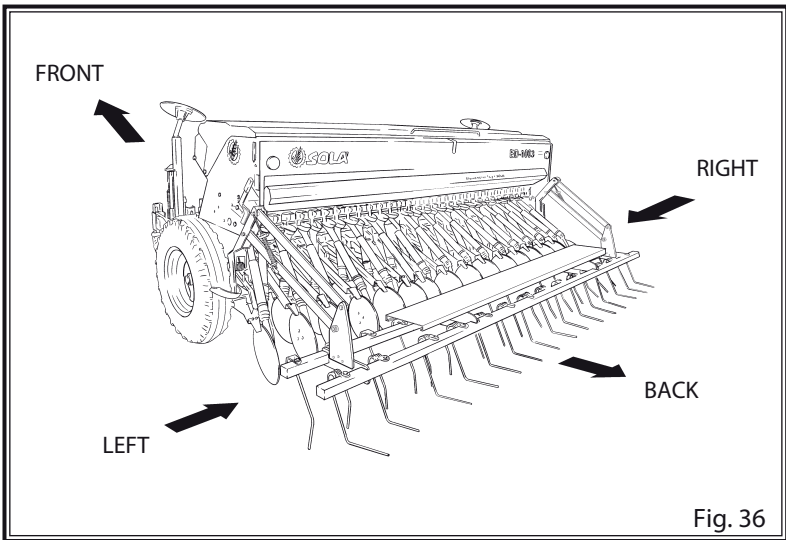

#### PRECAUTION:

BE CAREFUL WHEN MAINTAINING THE SEED DRILL, SHARP EDGES CAN CAUSE INJURY.



DO NOT WORK UNDER THE MACHINE WHEN IT IS RAISED. ALWAYS SECURE THE MACHINE PROPERLY TO PREVENT IT FROM COLLAPSING AS A PRESSURE LOSS IN THE TRACTOR CAN OCCUR.

## 9.2 CHASIS Y RODAJE DE SEMBRADORA Y COMBINADA

FIGURA	CÓDIGO	DENOMINACIÓN
1	RE-010200	HUSILLO CONTROL PROF. COMPLETO, CON EMPUÑADURA
2	PL-010200	EMPUÑADURA «PERA» 40, ROSCA M-10
3	PS-0101	EJE CONTROL PROFUNDIDAD, COMPLET $\circ$
4	EE-040102	EXCÉNTRICA BIELA
5	PS-0201	BIELA PORTABRAZOS EURO
6	MO-040112	BUJE LISO COMPLETO, MÁQUINAS 250 Y 300
6	MO-040111	BUJE LISO COMPLETO, MÁQUINA 350
6	RE-040300	BUJE LISO REFORZADO COMPLET $\circ$ , MÁQUINA 400
6	MO-040110	BUJE 29Z COMPLETO, MÁQUINAS 250 Y 300
6	MO-040105	BUJE 29Z COMPLETO, MÁQUINA 350
6	RE-040301	BUJE 29Z REFORZADO COMPLET $\circ$ , MÁQUINA 400
7	ME-040211	BUJE LISO SUELTO, MÁQUINAS 250, 300 Y 350
7	ME-040212	BUJE LISO REFORZADO SUELTO, MÁQUINA 400
8	ME-040209	BUJE 29Z SUELTO, MÁQUINAS 250, 300 Y 350
8	ME-040210	BUJE 29Z REFORZADO SUELTO, MÁQUINA 400
9	125 20 BI	ARANDELA PLANA DIN 125 020 BICROMA TADA
10	FE-601009	RETÉN DOBLE LABIO 042X072X10
10	FE-601001	RETÉN CHAPA Y GOMA 45/85
11	FE-600021	RODAMIENTO 30205
11	FE-600020	RODAMIENTO 30205 TIPO GPZ
11	FE-600007	RODAMIENTO 30206
12	FE-600023	RODAMIENTO 30207
12	FE-600022	RODAMIENTO 30207 TIPO GPZ
12	FE-600006	RODAMIENTO 30209
13	PS-2669	MANGUETA TRI 350 F-127
13	PS-2670	MANGUETA TRI 400 F-127
14	935 20/150	TUERCA ALMENADA DIN 935 M-20/150
14	935 27/150	TUERCA ALMENADA DIN 935 M-27/150

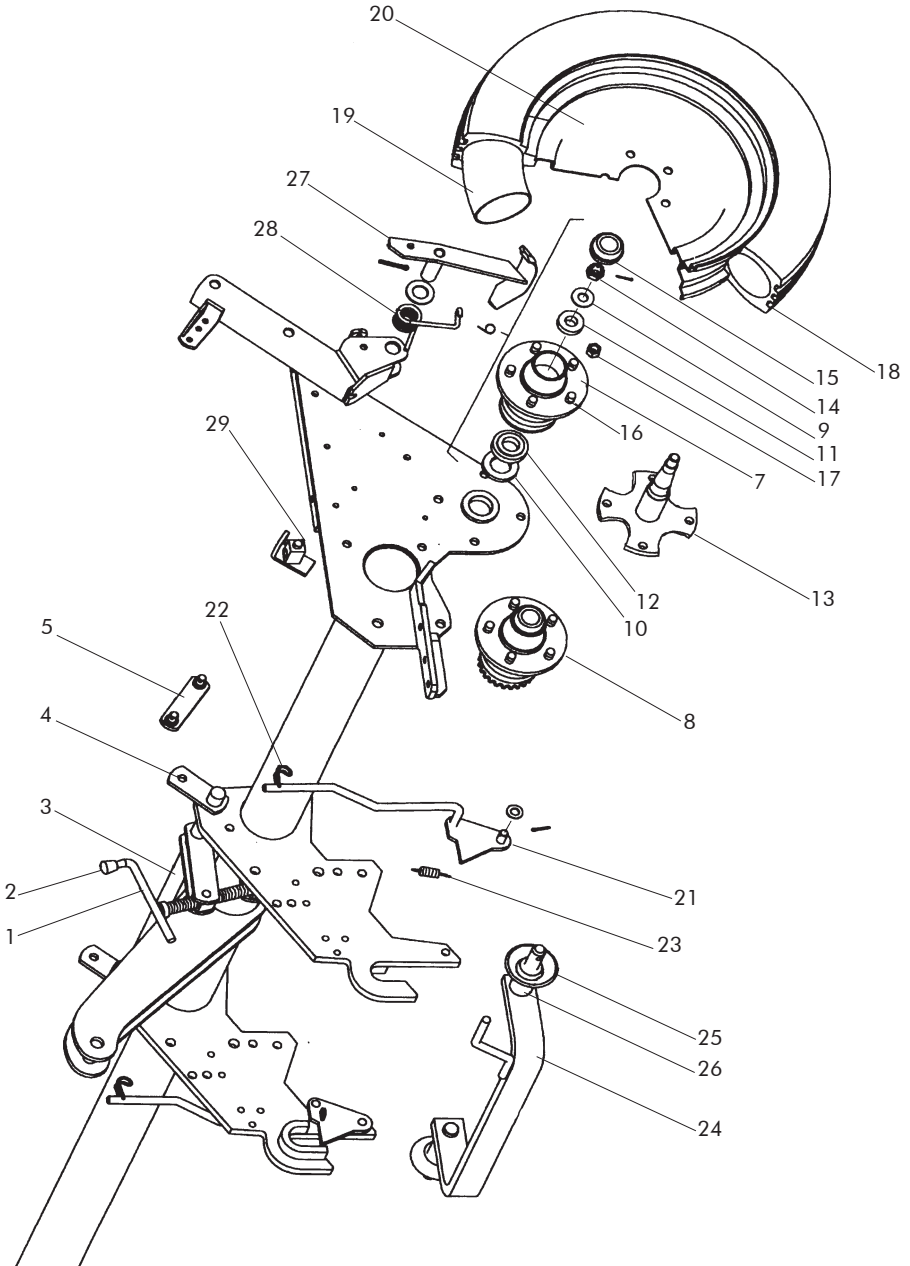

## 9.2 CHASIS Y RODAJE DE SEMBRADORA Y COMBINADA

<i>FIGURA</i>	<i>CÓDIGO</i>	<i>DENOMINACIÓN</i>
15	EE-040231	TAPACUBOS 250/300/350
15	EE-040234	TAPACUBOS BUJE 400
16	FE-614000	ESPÁRRAGO M-16/150
17	917 16/150 BI	TUERCA CÓNICA DEL ESPÁRRAGO M-16/150
18	PL-040210	NEUMÁTICO 7.50-16 8PR
19	PL-040212	CÁMARA PARA NEUMÁTICO 7.50-16
20	CO-040208	RUEDA METÁLICA 5.50-16 DESPL. -57
21	PS-0107/D	GATILLO EURO DERECHA, CON CLIP
21	PS-0107/I	GATILLO EURO IZQUIERDA, CON CLIP
22	ML-010100	CLIP PALANCA ENGANCHE (SUELTO)
23	ML-010101	MUELLE GATILLO ENGACHE
24	PS-0109	BARRA DE ENGANCHE ACODADA, CATEGORÍA 2
24	PS-010213	BARRA DE ENGANCHE ACODADA, CATEGORÍA 3
25	EE-010226	TOPE CÓNICO BARRA ENGANCHE
26	BU-010100	BULEN SUELTO BARRA ENGANCHE, CATEGORÍA 2
26	BU-010202	BULÓN SUELTO BARRA ENGANCHE, CATEGORÍA 3
27	PS-0149/D	RASCADOR RUEDA 7.50-16 DERECHA
27	PS-0149/I	RASCADOR RUEDA 5.50-16 IZQUIERDA
28	ML-010103/D	MUELLE RASCADOR EURO DERECHA
28	ML-010103/I	MUELLE RASCADOR EURO IZQUIERDA
29	ME-010203	GIRATORIA HUSILLO CULTIVADOR



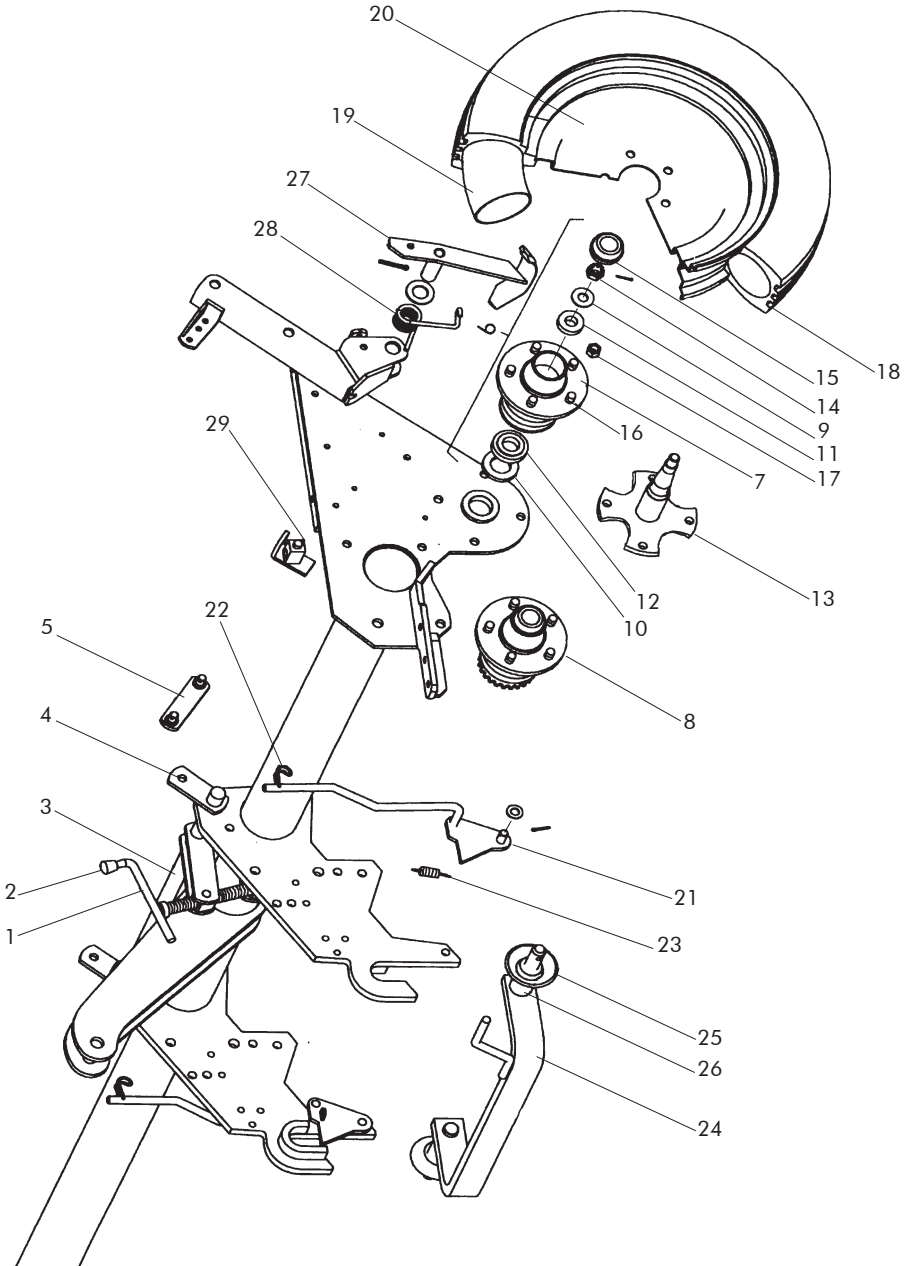

### 9.3 DISCOS ED-1003

<i>FIGURA</i>	<i>CÓDIGO</i>	<i>DENOMINACIÓN</i>
1	MO-051607	BRAZO DESPL 30 DER DISCO DER
1	PS-051610	BRAZO DES. 30 DCHA. DISCO DELANTERO ED-1003
1	MO-051636	BRAZO DESPL.30 DER. DISCO IZQ.
1	PS-051623	BRAZO DESPLAZADO 30 DER DISCO IZQ.
3	MO-051601	BRAZO RECTO DISCO TRASERO
3	PS-051602	BRAZO RECTO DISCO TRASERO ED-1003
4	MO-051609	BRAZO EXTREMO DER TRASERO ED-1003
4	PS-051608	BRAZO EXTREMO DES. DER ED-1003
5	FO-051600	DISCO SIEMBRA ED-1003
6	MO-051620	DISCO SIEMBRA
7	PS-051612-D	SOPORTE BRAZO EXTREMO DERECHA
7	PS-051612-I	SOPORTE BRAZO EXTREMO IZQUIERDA
9	ME-051601	EJE RODAMIENTO DISCO
10	MO-051631	BRAZO DESPL 90 IZQ COMPL. DISCO DER.
10	PS-051618	BRAZO DESPLAZADO 90 IZQ DISCO DER DELANT.
10	MO-051632	BRAZO DESPL 90 IZQ DISCO IZQ.
10	PS-051619	BRAZO DESPLAZADO 90 IZQ DISCO IZQ DELANT
11	MO-051628	BRAZO DESPL. 90 DER. DISCO DER.
11	PS-051615	BRAZO DESPLAZADO 90 DER DISCO DER. DELANT
11	MO-051630	BRAZO DESPL 90 DER DISCO IZQ.
11	PS-051617	BRAZO DESPLAZADO 90 DER DISCO IZQ. DELANT
12	MO-051602	BRAZO RECTO DISCO DER.
12	PS-051603	BRAZO RECTO DISCO DERECHO DELANTERO
12	MO-051629	BRAZO RECTO COMPLETO DISCO IZQ.
12	PS-051616	BRAZO RECTO DISCO IZQ. DELANTERO
13	MO-051608	BRAZO DESPL 30 IZQ. DISCO DER.
13	PS-051611	BRAZO DES. 30 IZQ. DISCO DELANTERO
13	MO-051635	BRAZO DESPL.30 IZQ. DISCO IZQ.

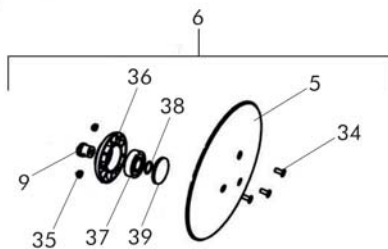
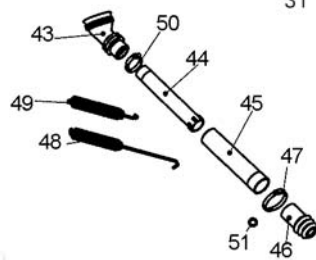
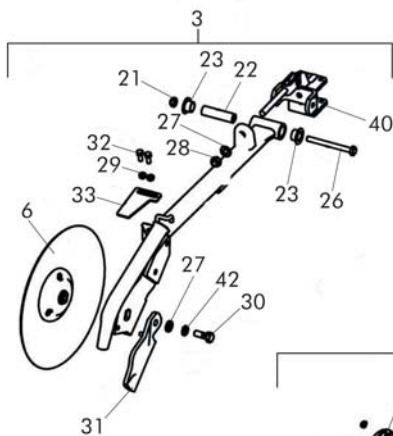
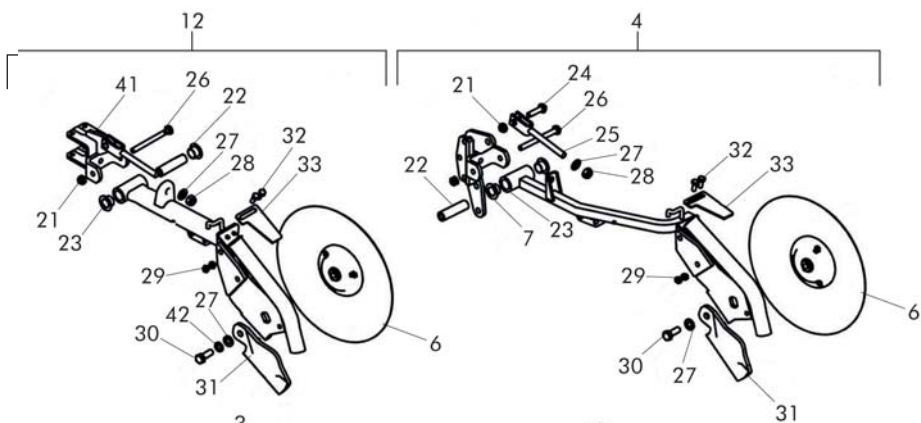
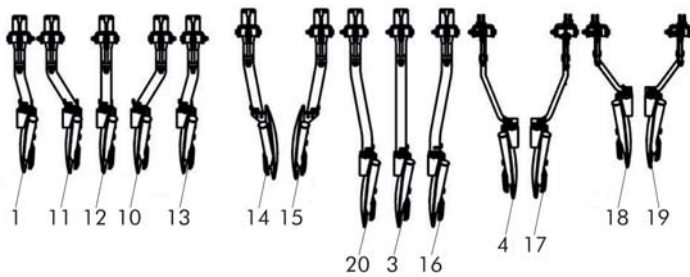

9.3 DISCOS ED-1003

<i>FIGURA</i>	<i>CÓDIGO</i>	<i>DENOMINACIÓN</i>
13	PS-051624	BRAZO DESPLAZADO 30 IZQ DISCO IZQ
14	MO-051605	BRAZO DESPL 103 DER DISCO DER
14	PS-051606	BRAZO DES. 103 D. DISCO DELANTERO
15	MO-051606	BRAZO DESPL 103 IZQ DISCO IZQ
15	PS-051607	BRAZO DES. 103 I. DISCO DELANTERO
16	MO-051604	BRAZO DESPL 52 IZQ DISCO IZQ
16	PS-051605	BRAZO DES. 52 I. DISCO TRASERO
17	MO-051610	BRAZO EXTREMO IZQ TRASERO ED-1003
17	PS-051609	BRAZO EXTREMO DES. IZQDA ED-1003
18	MO-051627-D	BRAZO EXTREMO DER EF-1103
18	PS-051614/D	BRAZO EXTREMO DER EF-1103
19	MO-051627-I	BRAZO EXTREMO IZQ EF-1103
19	PS-051614/I	BRAZO EXTREMO IZQ.EF-1103
20	MO-051603	BRAZO DESPL 52 DER DISCO IZQ
20	PS-051604	BRAZO DES. 52 D. DISCO TRASERO ED-1003
21	985 12	TUERCA DIN 985 M12
22	ME-051322	TUBO INTERIOR ARTICULACION BRAZO
23	PL-050207	CASQUILLO ARTICULACIÓN BRAZO
24	933 10X40 8.8 B	TORNILLO DIN 933 M10x40 8,8 BI
25	CO-050200	SENSOR CON HORQUILLA SOLDADA
26	931 12X110 8.8B	TORNILLO DIN 931 M12x110 8.8 BI
27	125 12 BI	ARANDELA DIN 125 M12 BI
28	985 12-150	TUERCA DIN 985 M12/150
29	985 8	TUERCA DIN 985 M8
30	933 12X35 8.8B	TORNILLO DIN 933 M12x35 8,8 BI
31	FU-051600-I	CUCHILLA ABRESURCOS IZQDA SD-1003
31	FU-051600-D	CUCHILLA ABRESURCOS DER
32	32 933 8X20 8.8B	TORNILLO DIN 933 M8x20 8,8 BI
33	PX-051617	RASCADOR EXTERIOR DISCO

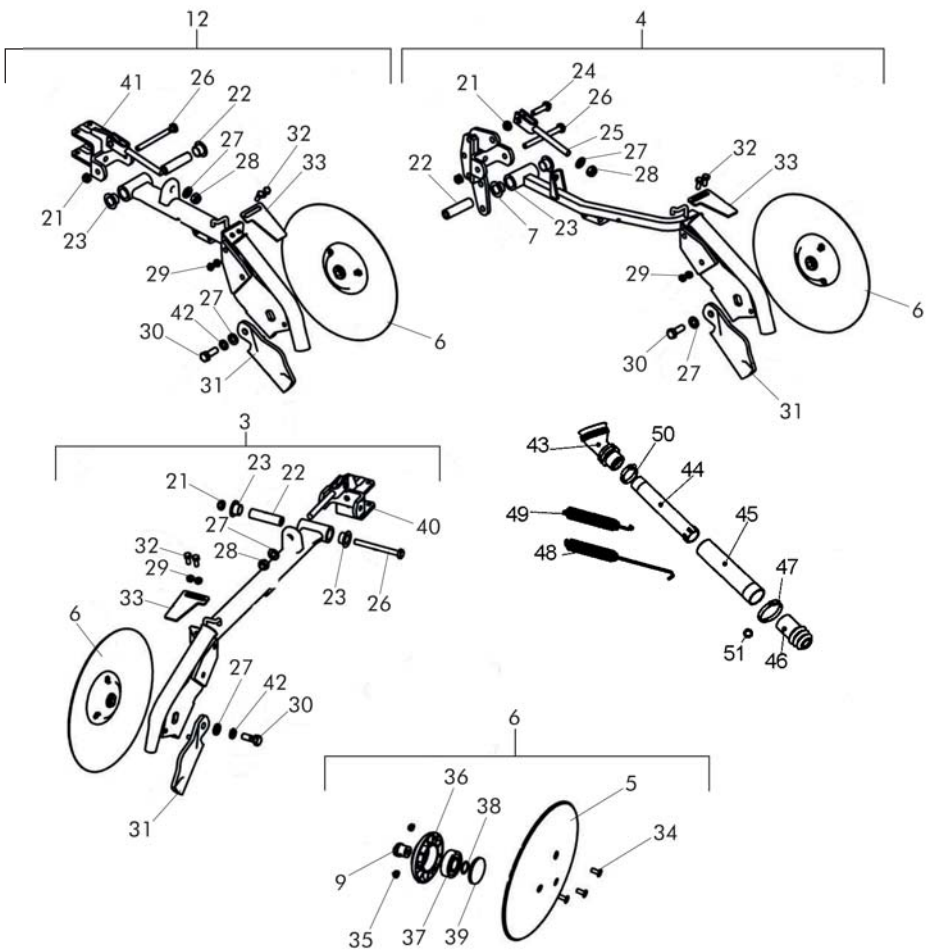
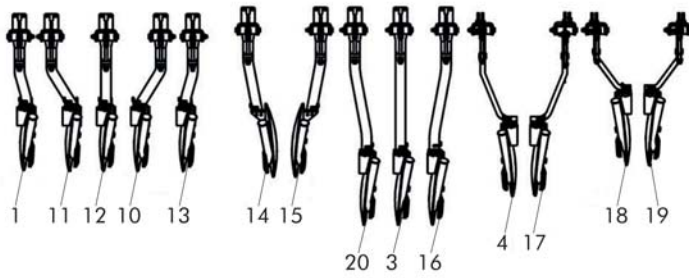

9.3 DISCOS ED-1003

FIGURA	CÓDIGO	DENOMINACIÓN
34	7991 8X20 10 BI	TORNILLO DIN 7991 M8x20 BI
35	35 985 8	TUERCA DIN 985 M8
36	PL-051601	BUJE DISCO
37	FE-600078	RODAMIENTO 6305 2RS CLASE A
38	38 471 25	ANILLO SAEGER DIN 471 Ø25
39	PL-051602	TAPA BUJE DISCO
40	PS-051377	SOPORTE BRAZO DISCO DELANTERO
41	PS-051376	SOPORTE BRAZO DISCO TRASERO
42	127 12 BI	ARANDELA GROWER DIN 127 12 BI
43	PL-051400	FUELLE FLEXIBLE SUPERIOR EF-801
44	PL-052005	TUBO TELESCOPICO INTERIOR Ø 40X400
44	PL-052008	TUBO TELESCOPICO INTERIOR Ø 40X250
45	PL-052006	TUBO TELESCOPICO EXTERIOR Ø 50X280
45	PL-052007	TUBO TELESCOPICO EXTERIOR Ø 50X230
46	PL-051600	FUELLE ACOPLAMIENTO TUBO A DISCO ED-1003
47	FE-606003	ABRAZADERA 40-60/9 W1 TORRO
48	ML-051602	MUELLE BRAZO LARGO
49	ML-051601	MUELLE BRAZO CORTO
50	FE-606001	BRIDA SINFIN 32/50
51	ME-051603	ANILLO AMARRE TUBO-BRAZO ED-1003

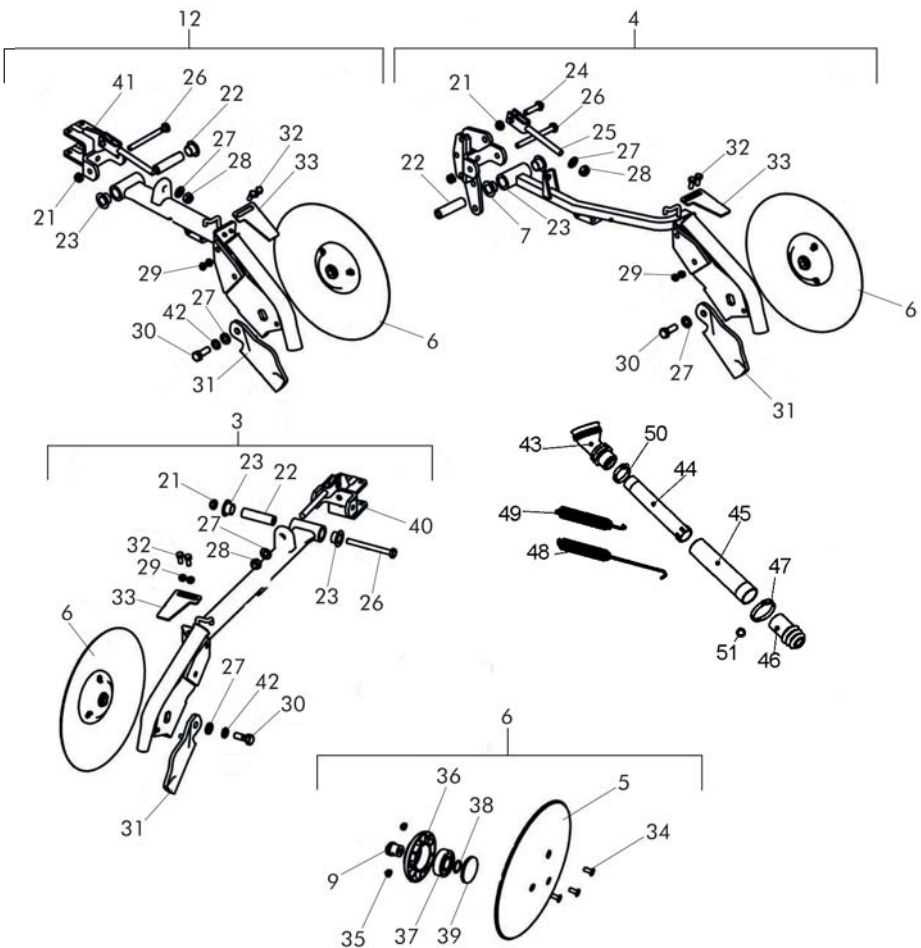
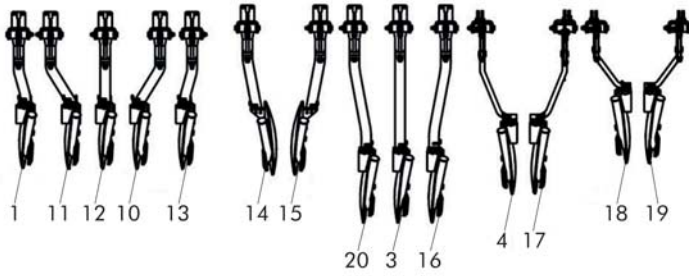

## 9.4 VARIADOR SEMILLA

<i>FIGURA</i>	<i>CÓDIGO</i>	<i>DENOMINACIÓN</i>
1	MO-0601	VARIADOR SEMILLA SV-04
2	ME-040100	PIÑÓN 22Z PARA CADENA DE 1/2"
3	PL-040100	PIÑÓN TENSOR CADENA 1/2"
4	MV-09	VOLANTE CON TORNILLO M-10 ROSCA IZQUIERDA
5	PX-040204	ÍNDICE PALANCA VARIADOR
6	PS-0610	PALANCA REGULACIÓN VARIADOR SEMILLA
7	AD-040200	ADHESIVO GRADUACIÓN VARIADOR SEMILLA
8	PS-0618	TAPA CAJA VARIADOR SEMILLA CON GRADUADOR
9	TA-0618	EXCÉNTRICA ESTRELLA VARIADOR SEMILLA
10	MO-0605	CONJUNTO EJE GIRO LIBRE SEMILLA
11	RE-040201	EJE TRANSMISIÓN VARIADOR SEMILLA, SUELTO
12	ME-040226/D	LEVA DE ARRASTRE LARGA DERECHA
12	ME-040226/I	LEVA DE ARRASTRE LARGA IZQUIERDA
13	RODILLO 12X18	RODILLO 012X18
14	RE-040202	TETÓN POSICIONADOR RODILLO CON MUELLE
15	PL-040200	ANILLO DE LA LEVA
16	471 8	ANILLO SAEGER DIN 471 08
17	PS-0611	HORQUILLA TOPE LEVAS VARIADOR SEMILLA
18	BU-040200	BULÓN TOPE LEVAS
19	PL-040206	CASQUILLO TOPE LEVAS
20	471 12	ANILLO SAEGER DIN 471 012
21	ML-040101	MUELLE RETORNO LEVAS
22	PL-040207	CASQUILLO 020X025X10
23	PL-040208	CASQUILLO 030X035X10
24	FE-601004	RETÉN DOBLE LABIO 020X028X6
25	FE-601005	RETÉN DOBLE LABIO 030X040X7
26	HI-707005	MIRILLA NIVEL ACEITE 1/2" GAS
27	1481 6X40 BI	PASADOR ELÁSTICO DIN 1481 06X40 BICROMATADO
28	PS-0637	TAPADENA SEMILLA CON ESPÁRRAGOS EURO



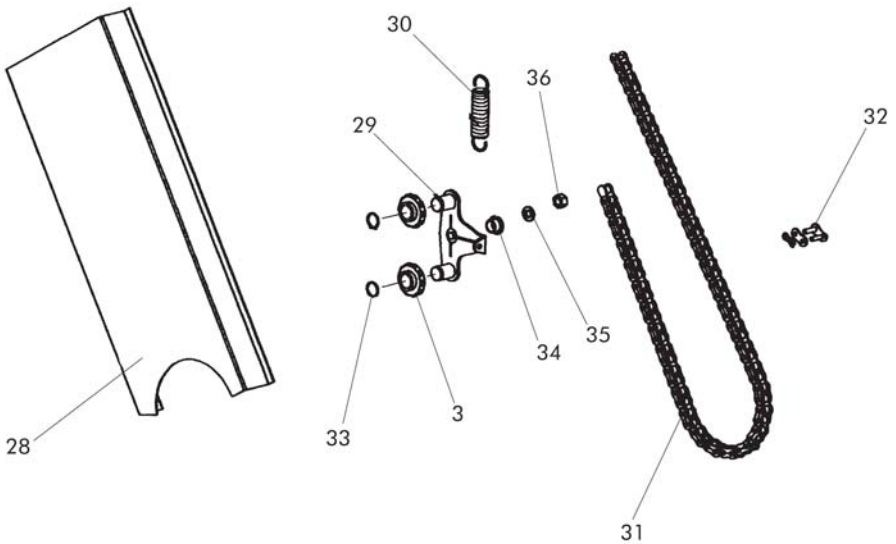
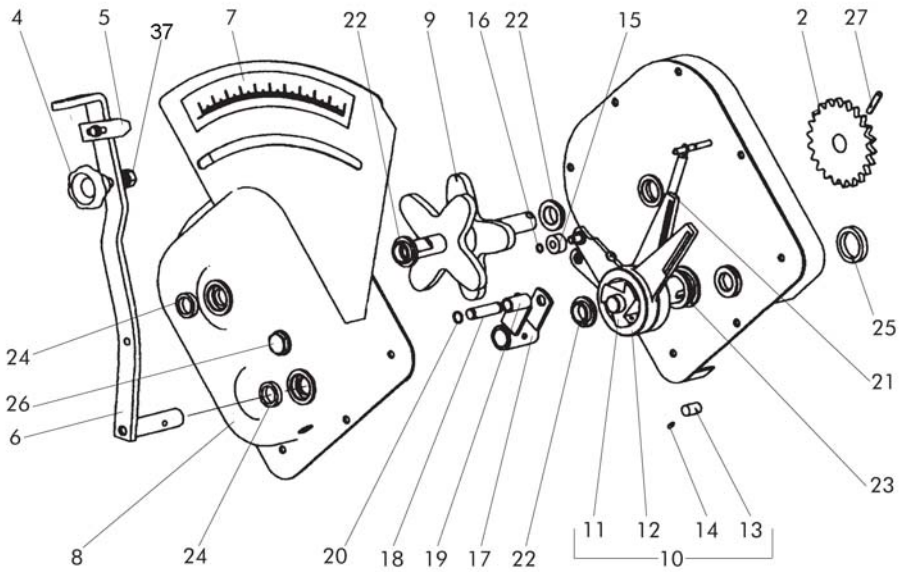

9.4 VARIADOR SEMILLA

<i>FIGURA</i>	<i>CÓDIGO</i>	<i>DENOMINACIÓN</i>
<b>29</b>	CO-040300	TENSOR CADENA
<b>30</b>	ML-010101	MUELLE GATILLO ENGANCHE
<b>31</b>	FE-605004	CADENA 1/2" VARIADOR SEMILLA, L=1499
<b>32</b>	FE-605025	ENGANCHE PARA CADENA DE 1/2"
<b>33</b>	471 16	ANILLO SAEGER DIN 471 016
<b>34</b>	FE-600008	CASQUILLO DE FRICCIÓN 012X014X9
<b>35</b>	125 8 BI	ARANDELA PLANA DIN 125 08 BICROMATADA
<b>36</b>	985 8	TUERCA DIN 985 M-8

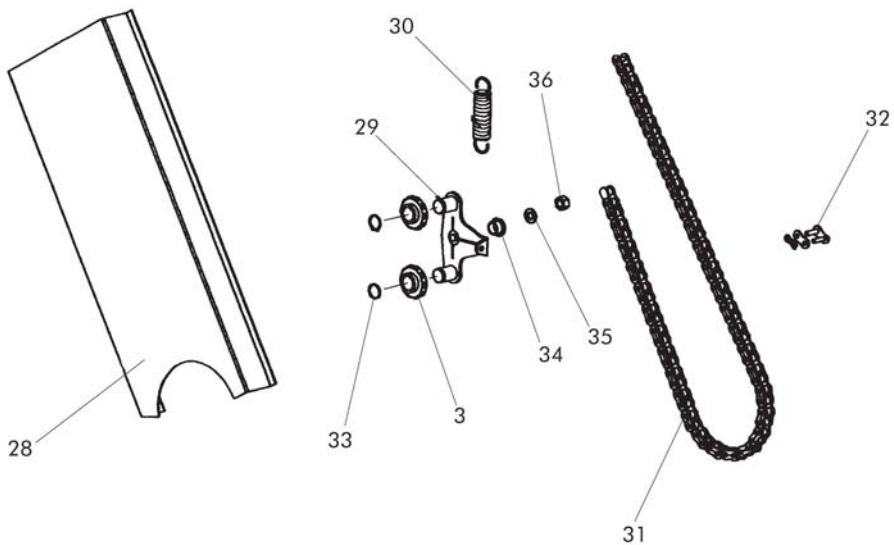
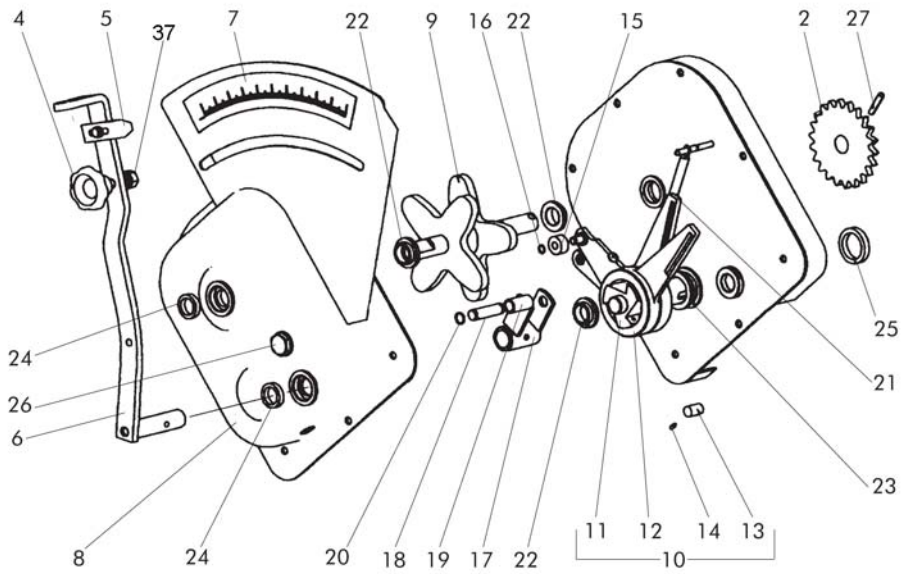

## 9.5 VARIADOR ABONO

<i>FIGURA</i>	<i>CÓDIGO</i>	<i>DENOMINACIÓN</i>
1	MO-0602	VARIADOR ABONO SV-05
2	ME-040101	PIÑÓN 22Z PARA CADENA DE 1/2"
3	PL-040100	PIÑÓN TENSOR CADENA 1/2"
4	MV-09	VOLANTE CON TORNILLO M-10 ROSCA IZQUIERDA
5	PX-040204	ÍNDICE PALANCA VARIADOR
6	PS-0619	PALANCA REGULACIÓN VARIADOR ABONO
7	AD-040201	ADHESIVO GRADUACIÓN VARIADOR ABONO
8	PS-0627	TAPA CAJA VARIADOR ABONO CON GRADUADOR
9	RE-040200	EXCÉNTRICA ESTRELLA VARIADOR ABONO
10	MO-0606	CONJUNTO EJE GIRO LIBRE ABONO
11	RE-040203	EJE TRANSMISIÓN VARIADOR ABONO, SUELTO
12	ME-040232/D	LEVA DE ARRASTRE CORTA DERECHA
12	ME-040232/I	LEVA DE ARRASTRE CORTA IZQUIERDA
13	RODILLO 12X18	RODILLO 012X18
14	RE-040202	TETÓN POSICIONADOR RODILLO CON MUELLE
15	PL-040200	ANILLO DE LA LEVA
16	471 8	ANILLO SAEGER DIN 471 08
17	PS-0620	HORQUILLA TOPE LEVAS VARIADOR ABONO
18	BU-040200	BULÓN TOPE LEVAS
19	PL-040206	CASQUILLO TOPE LEVAS
20	471 12	ANILLO SAEGER DIN 471 012
21	ML-040101	MUELLE RETORNO LEVAS
22	PL-040207	CASQUILLO 020X025X10
23	PL-040208	CASQUILLO 030X035X10
24	FE-601004	RETÉN DOBLE LABIO 020X028X6
25	FE-601005	RETÉN DOBLE LABIO 030X040X7
26	HI-707005	MIRILLA NIVEL ACEITE 1/2" GAS
27	1481 6X28 BI	PASADOR ELÁSTICO DIN 1481 06X28 BICROMATADO
28	PS-0638	TAPADENA ABONO CON ESPÁRRAGOS EURO

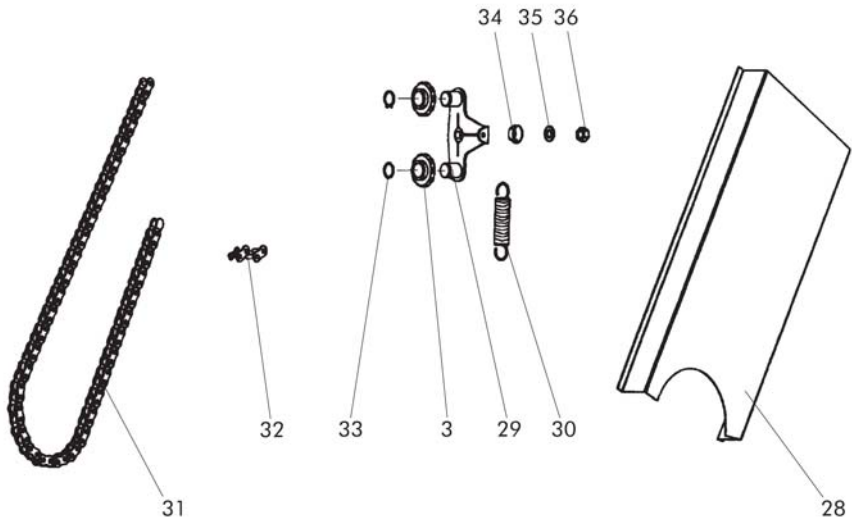
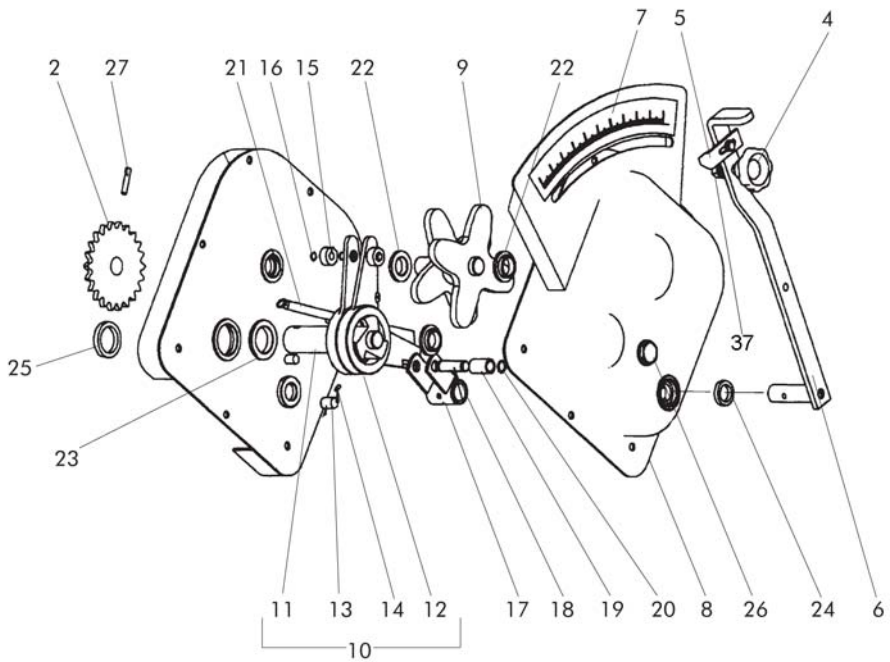

9.5 VARIADOR ABONO

<i>FIGURA</i>	<i>CÓDIGO</i>	<i>DENOMINACIÓN</i>
<b>29</b>	CO-040300	TENSOR CADENA
<b>30</b>	ML-010101	MUELLE GATILLO ENGANCHE
<b>31</b>	FE-605005	CADENA 1/2" VARIADOR ABONO, L=1422
<b>32</b>	FE-605025	ENGANCHE PARA CADENA DE 1/2"
<b>33</b>	471 16	ANILLO SAEGER DIN 471 016
<b>34</b>	FE-600008	CASQUILLO DE FRICCIÓN 012X014X9
<b>35</b>	125 8 BI	ARANDELA PLANA DIN 125 08 BICROMATADA
<b>36</b>	985 8	TUERCA DIN 985 M-8

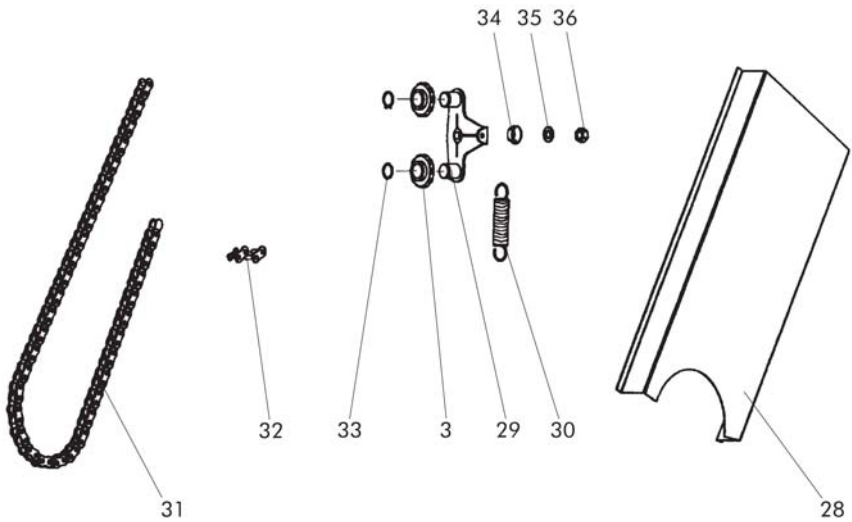
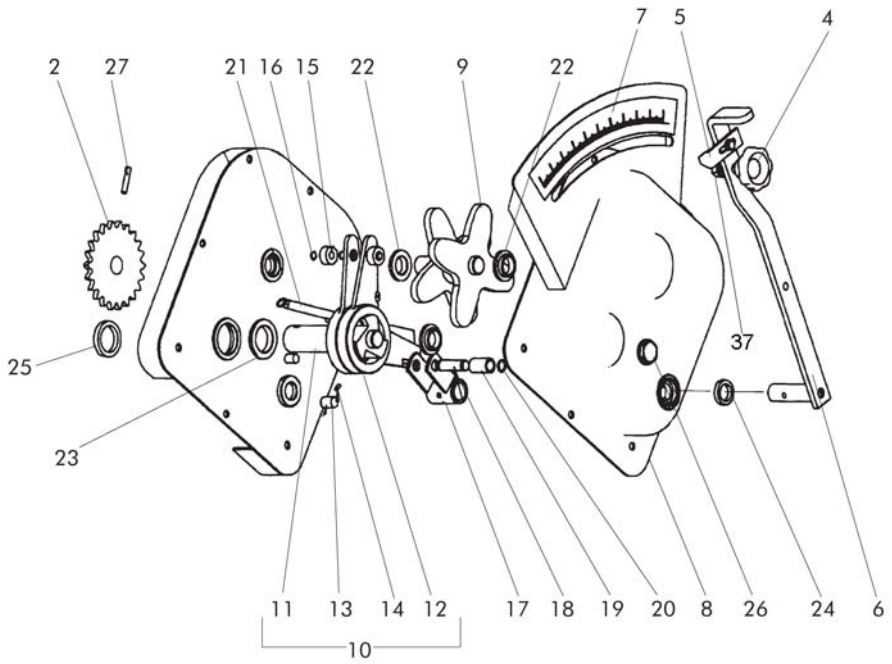

## 9.6 TOLVA SEMBRADORA/COMBINADA

<i>FIGURA</i>	<i>CÓDIGO</i>	<i>DENOMINACIÓN</i>
1	PS-0404	TOLVA SEMBRADORA 250
1	PS-0405	TOLVA SEMBRADORA 300
1	PS-0406	TOLVA SEMBRADORA 350
1	PS-0407	TOLVA SEMBRADORA 400
1	PS-0501	TOLVA COMBINADA 250
1	PS-0502	TOLVA COMBINADA 300
1	PS-0503	TOLVA COMBINADA 350
1	PS-0511	TOLVA COMBINADA 400
2	PS-1301	TAPA TOLVA 250
2	PS-1302	TAPA TOLVA 300
2	PS-1303	TAPA TOLVA 350
2	PS-1304	TAPA TOLVA 400
3	PS-1401	CRIBA 250
3	PS-1402	CRIBA 300
3	PS-1403	CRIBA 350
3	PS-1404	CRIBA 400
4	PS-1309	DELANTAL TAPA TOLVA 250 SEMBRADORA
4	PS-1310	DELANTAL TAPA TOLVA 300 SEMBRADORA
4	PS-1311	DELANTAL TAPA TOLVA 350 SEMBRADORA
4	PS-1312	DELANTAL TAPA TOLVA 400 SEMBRADORA
4	PS-1305	DELANTAL TAPA TOLVA 250 COMBINADA
4	PS-1306	DELANTAL TAPA TOLVA 300 COMBINADA
4	PS-1307	DELANTAL TAPA TOLVA 350 COMBINADA
4	PS-1308	DELANTAL TAPA TOLVA 400 COMBINADA
5	MB-60	BANDEJA DE VACIADO 250
5	MB-61	BANDEJA DE VACIADO 300
5	MB-62	BANDEJA DE VACIADO 350
5	MB-63	BANDEJA DE VACIADO 400
6	MO-1638	CONJUNTO CIERRE TAPA TOLVA CON MUELLE



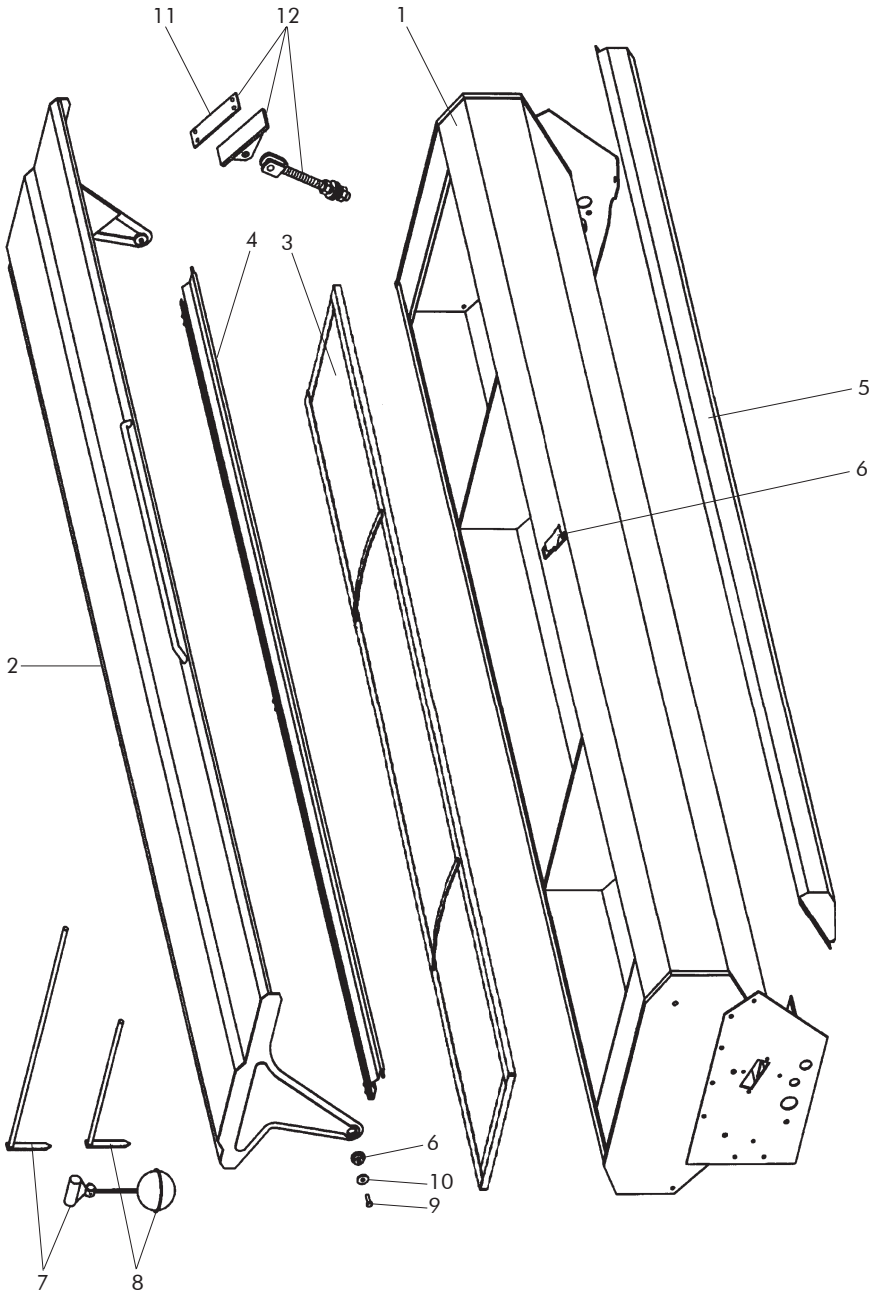

## 9.6 TOLVA SEMBRADORA/COMBINADA

<i>FIGURA</i>	<i>CÓDIGO</i>	<i>DENOMINACIÓN</i>
7	RE-020200	CONJUNTO COMPLETO INDICADOR NIVEL SEMILLA
8	RE-020202	CONJUNTO COMPLETO INDICADOR NIVEL ABONO
9	BU-020700	BULÓN GUÍA TOPE TAPA TOLVA
10	EE-030200	ARANDELA 030 CON AGUJERO 08,5 BICROMATADA
11	PL-020201	CHAPA GOMA UNIÓN TOLVA-CHASIS
12	RE-020201	CONJUNTO UNIÓN TOLVA CHASIS

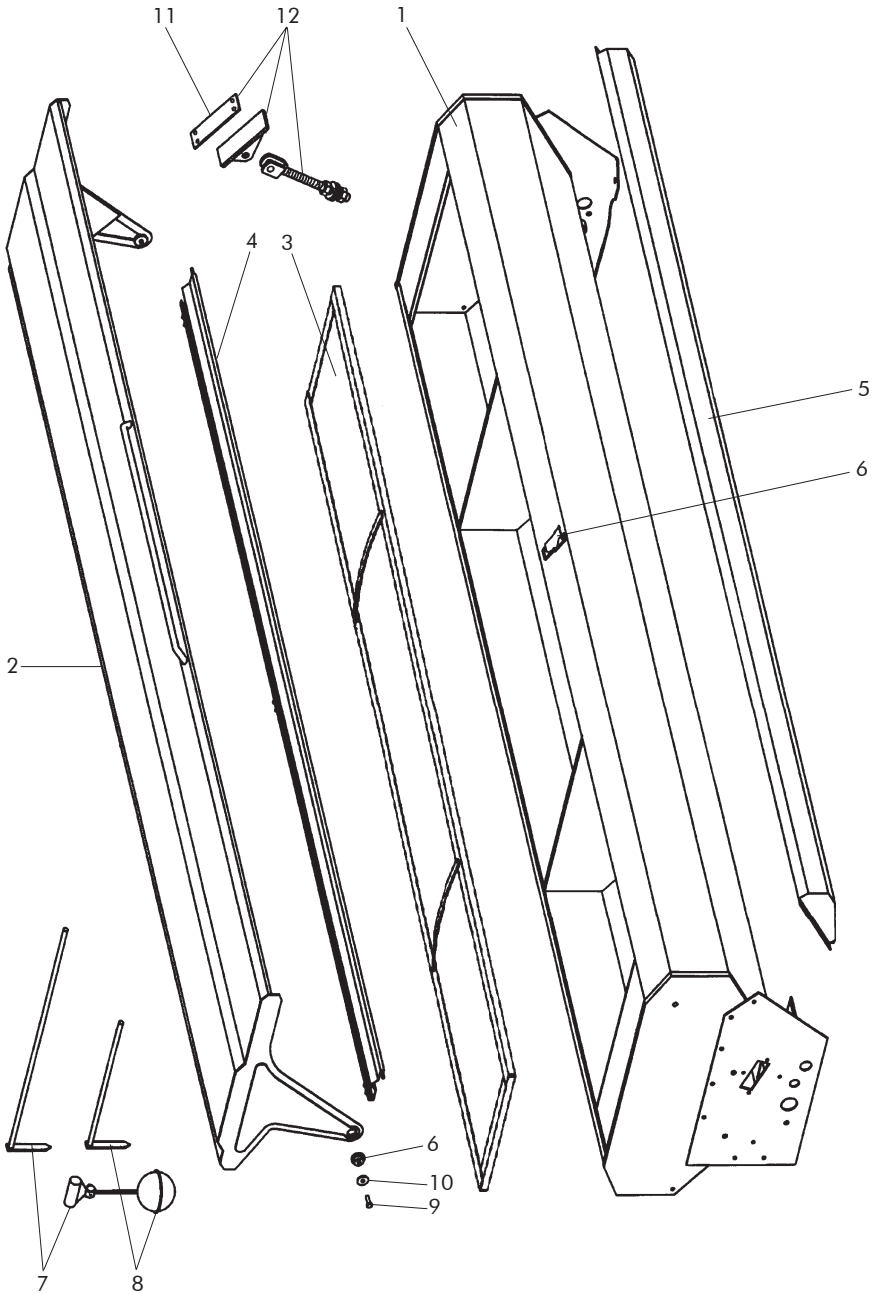

9.7 TOLVA SEMBRADORA/COMBINADA G.C

<i>FIGURA</i>	<i>CÓDIGO</i>	<i>DENOMINACIÓN</i>
1	PS-030808	DELANTAL TAPA TOLVA GC 300
1	PS-030809	DELANTAL TAPA TOLVA GC 350
1	PS-030810	DELANTAL TAPA TOLVA GC 400
2	MO-1638	CIERRE TAPA TOLVA C/MUELLE
3	RE-021000	CONJUNTO COMPLETO INDICADOR NIVEL GRANO GC
4	PS-020912	PALANCA FONDO MÓVIL GC
5	PS-021000/D	APOYA TOLVA GC DERECHA
5	PS-021000/1	APOYA TOLVA GC IZQUIERDA

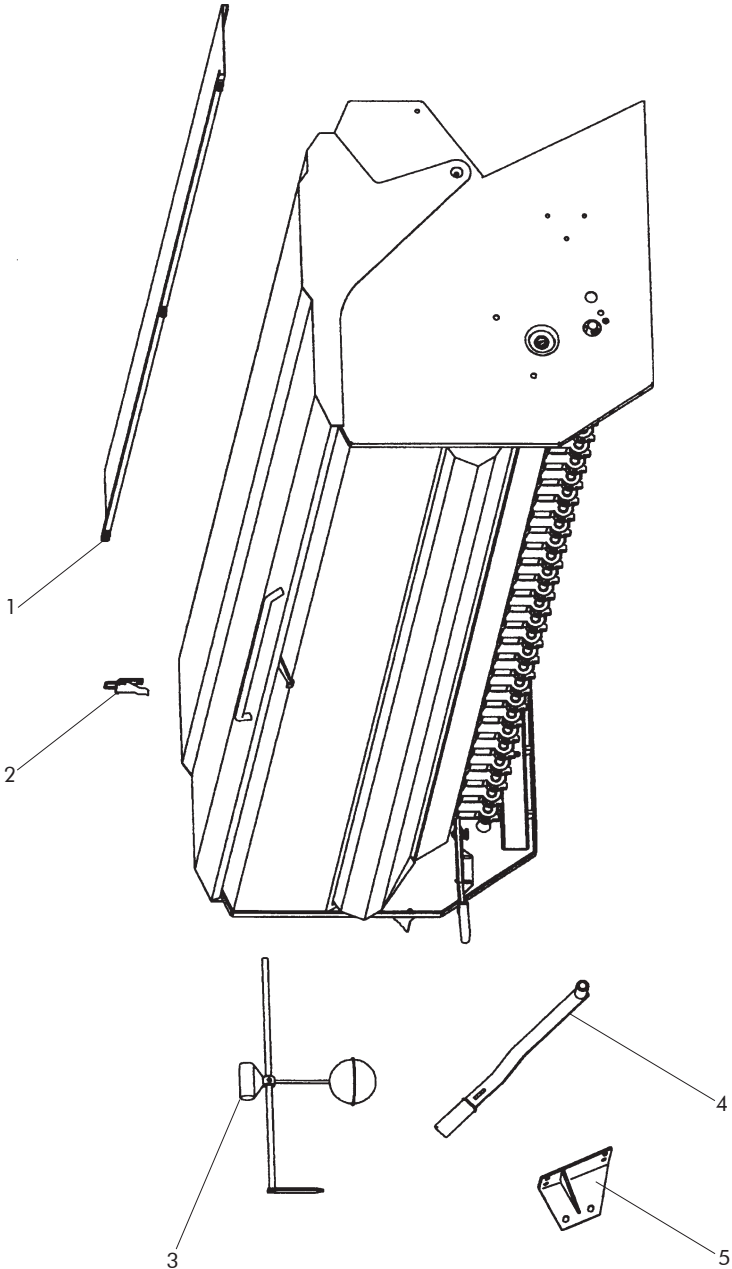

## 9.8 DISTRIBUCIÓN SEMBRADORA/COMBINADA

<i>FIGURA</i>	<i>CÓDIGO</i>	<i>DENOMINACIÓN</i>
1	MD-11	DISTRIBUIDOR SEMBRADORA
2	MD-12	DISTRIBUIDOR COMBINADA INOXIDABLE
3	PL-040201	RODILLO DISTRIBUIDOR SEMILLA
4	EE-040200	ARANDELA ESTRIADA
5	EE-040202	ARANDELA ESTRIADA INOXIDABLE
6	PL-040205	TAPETA FONDO MÓVIL
7	PL-040202	RODILLO DISTRIBUIDOR ABONO
8	EE-040232	BRIDA SOPORTE TAPETA FONDO MÓVIL BL
9	EE-040232/P	BRIDA SOPORTE TAPETA FONDO MÓVIL PINTADA
10	ML-020200	MUELLE TAPETA FONDO MÓVIL BICROMATADO
11	ML-020201	MUELLE TAPETA FONDO MÓVIL INOXIDABLE
12	933 8X20B PUNTA	TORNILLO DIN 933 M-8X20 CON PUNTA BL
13	933 8x20 I PUNTA	TORNILLO DIN 933 M-8X20 CON PUNTA INOXIDABLE
14	ML-040203	CLIP «R» TAPETA ABONO INOXIDABLE
15	EE-040227	TAPETA FONDO ABONO LARGA
15	EE-040226	TAPETA FONDO ABONO CORTA
16	EE-040228	TAPETA CORREDERA BICROMATADA
16	EE-040229	TAPETA CORREDERA INOXIDABLE
17	EE-040230	TAPETA SUSTITUCIÓN DISTRIBUIDOR
18	PS-0416-17-18	EJE AGITADOR 250/300/350/400
19	TA-0403/04/05/06	EJE DISTRIBUIDOR 250/300/350/400
20	TA-0506/07/08/12	EJE DISTRIBUIDOR ABONO 250/300/350/400
21	PM-0402/12/13/14	EJE FONDO MÓVIL 250/300/350/400
22	EE-020215	TAPA SOPORTE AGITADOR
23	PX-020218	TAPA BUJE AGITADOR TOLVA COMBI
24	EE-040219	GRADUADOR PALANCA FONDO MÓVIL
25	PS-0410	PALANCA FONDO MÓVIL
26	PS-0408	PALANCA DISTRIBUIDOR
27	PL-040203	MANOPLA PVC PARA PLETINA 30X8

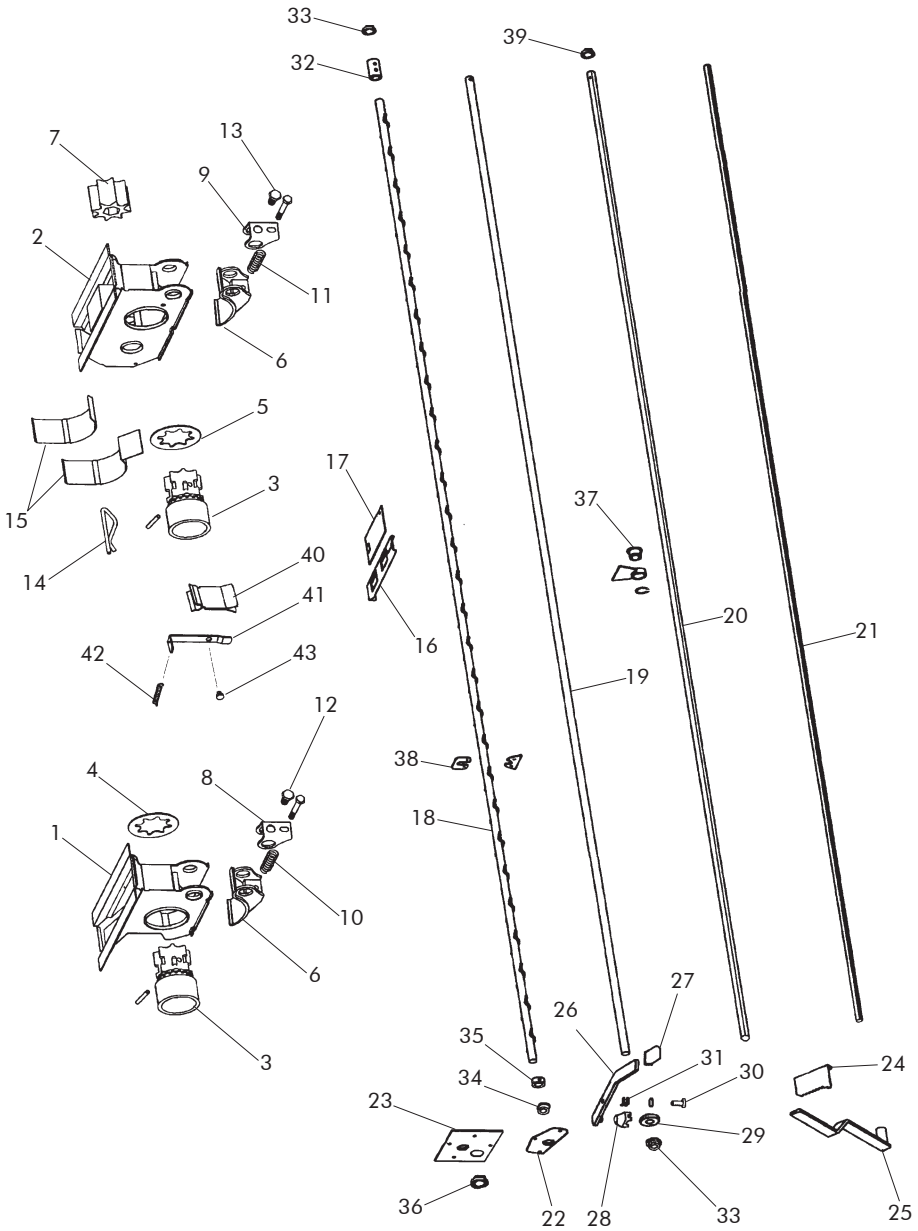

## 9.8 DISTRIBUCIÓN SEMBRADORA/COMBINADA

<i>FIGURA</i>	<i>CÓDIGO</i>	<i>DENOMINACIÓN</i>
28	ME-040223	ENCAJE RULINA
29	ME-040214	RULINA DE ARRASTRE 020 MECANIZADA
30	BU-040208	BULÓN ARTICULACIÓN PALANCA DISTRIBUCIÓN
31	ML-020202	MUELLE PALANCA REGULACIÓN
32	ME-040227	TUBO UNIÓN VARILLA AGITADOR
33	PL-020204	CASQUILLO 020,2X025X10
34	PL-020205	CASQUILLO 020,2X025X10 CON MUESCA
35	ME-020202	ANILLO RETENCIÓN CASQUILLO AGITADOR
36	PL-040208	CASQUILLO 030X035X10
37	PL-020203	CASQUILLO BUJE EJE ABONO
38	EE-040215	PUENTE AMARRE VARILLA AGITADOR
39	PL-020206	CASQUILLO 018X025X10
40	EE-040303	SEPARADOR CENTRAL COMBINADA 2 TUBOS
41	EE-050201	PLETINA TOPE BOQUILLA INOX.
42	ML-020100	MUELLE DE LA PLETINA TOPE BOQUILLA
43	EE-040100	REMACHE TOPE BOQUILLA



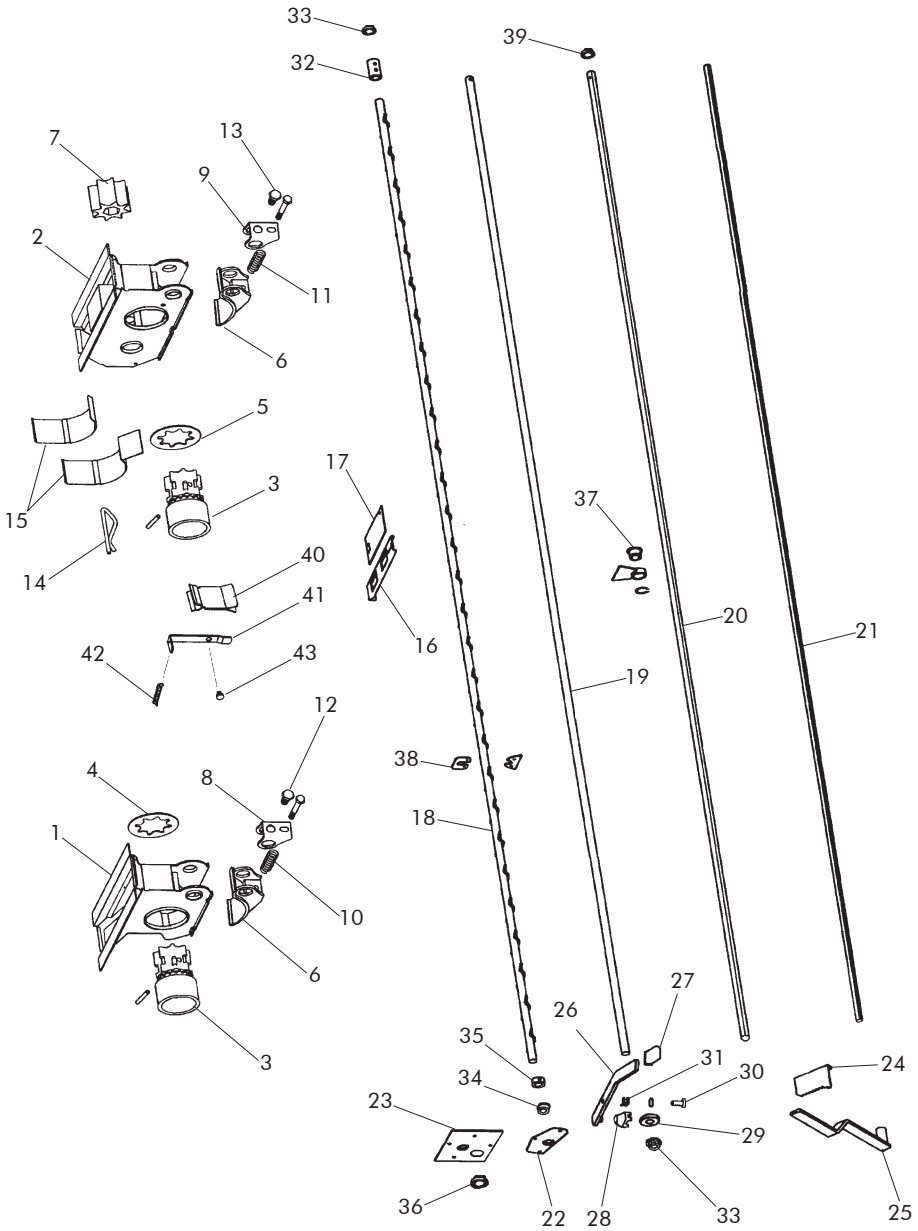

## 9.9 RASTRA DE PÚAS FLEXIBLES

<i>FIGURA</i>	<i>CÓDIGO</i>	<i>DENOMINACIÓN</i>
1	ML-080104	MUELLE BRAZO RASTRA EPI-6
2	PS-1710	TENSOR MUELLE RASTRA EPI
3	PS-1735	TUBO INTERIOR MUELLE
4	985 16	TUERCA DIN 985 M-16
5	985 12	TUERCA DIN 985 M12
6	ML-080400/D-I	PUA RASTRA DERECH/IZQ SD
7	PS-1742/D	BRAZO MOTRIZ RASTRA EPI-6 EURO DERECHA
7	PS-1742/1	BRAZO MOTRIZ RASTRA EPI-6 EURO IZQUIERDA
8	PS-1709	BRAZO TENSOR RASTRA EPI-6 EURO
9	BU-080202	BULÓN LARGO 020X78
10	PS-1736/37/38	BARRAS RASTRA EPI-6 250/300/350
11	CN-817001	CONTERA DE PLASTICO PARA TUBO 50X50X3
12	9021 12 BI	ARANDELA DIN 9021 M12 BICROMATADA
13	PS-1740	PELDAÑO RASTRA EPI-6
14	931 12x80 BI	TORNILLO DIN 931 M-12X80 BICROMATADO
15	ML-080101	MUELLE DEL PELDAÑO RASTRA
16	BU-080206	BULÓN 016X37 BICROMATADO

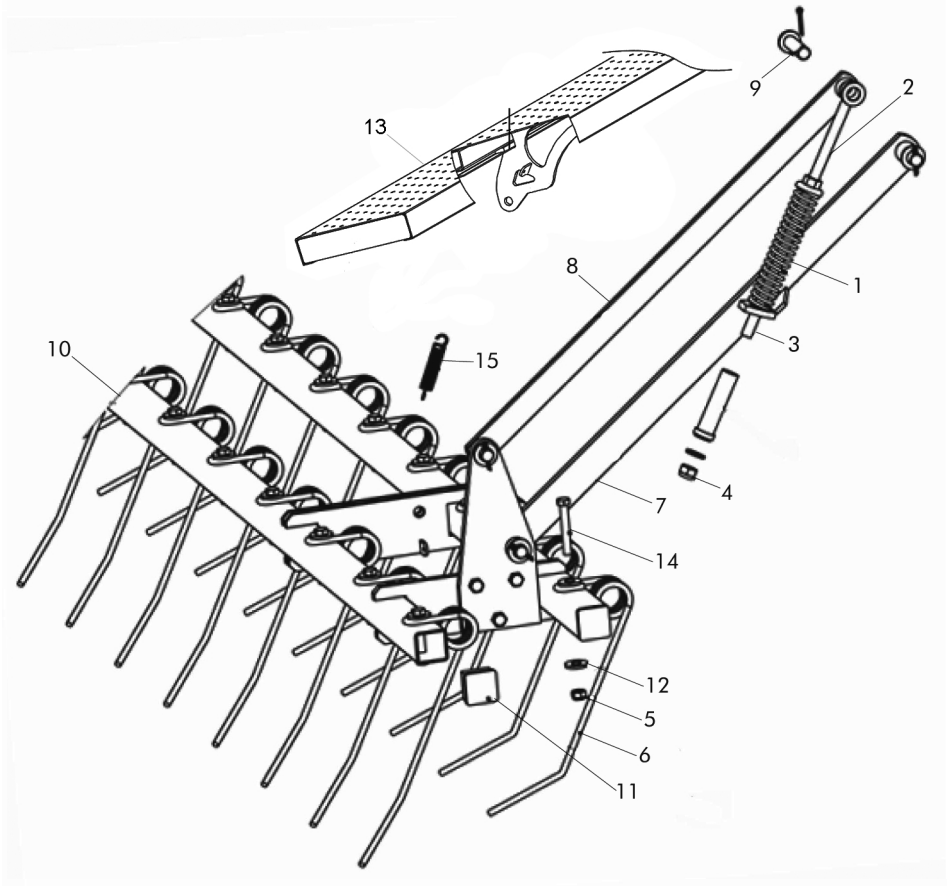

## 9.10 RASTRA ARTICULADA 4 METROS

<i>FIGURA</i>	<i>CÓDIGO</i>	<i>DENOMINACIÓN</i>
1	PS-080311	BARRA SOPORTE RASTRA ARTICULADA 400 EPI-7
2	PS-080312	PELDAÑO ABATIBLE RASTRA ARTICULADA 400 EPI-7
3	PS-080310	MEDIA BARRA RASTRA ARTICULADA 400 EPI-7
4	PS-080307	BRAZO TENSOR RASTRA 400 EPI-3
5	PS-080308/D	BRAZO MOTRIZ RASTRA 400 EPI-3 DERECHA
5	PS-080308/I	BRAZO MOTRIZ RASTRA 400 EPI-3 IZQUIERDA
6	PS-1735	TUBO GUÍA TOPE MUELLE RASTRA
7	PS-080306	TENSOR BRAZO RASTRA 400 EPI-3
8	EE-080306	TAPETA MUELLE BRAZO RUEDA BICROMATADA
9	ML-080104	MUELLE BRAZO RASTRA
10	BU-080202-	BULÓN LARGO Ø20X78
11	ML-080103	MUELLE DOBLE PÚA TRASERO
12	9021 12 BI	ARANDELA DIN 9021 M12 BICROMATADA
13	PS-082105	PELDAÑO 250-300-350-400 RASTRA EPI6
14	BU-080206	BULÓN Ø16X37 BICROMATADO
15	CN-817001	TAPÓN CUADRADO PARA TUBO DE 50X50X3
17	BU-080205	BULÓN BRAZO RASTRA 400
18	931 12X80 8.8 B	TORNILLO DIN 931 M-12X80 8.8 BICROMATADO
19	934 12 BI	TUERCA DIN 934 M-12 BICROMATADA
20	934 16 BI	TUERCA DIN 934 M-16 BICROMATADA
21	125 16BI	ARANDELA PLANA DIN 125 Ø16 BICROMATADA
22	985 16	TUERCA DIN 985 M-16
23	7980 12 BI	ARANDELA GROWER DIN 7980 012 BICROMATADA
24	125 20BI	ARANDELA PLANA DIN 125 Ø20 BICROMATADA
25	94 5X25 BI	PASADOR ALETAS DIN 94 Ø5X25 BICROMATADO
26	94 5X32 BI	PASADOR ALETAS DIN 94 Ø5X32 BICROMATADO

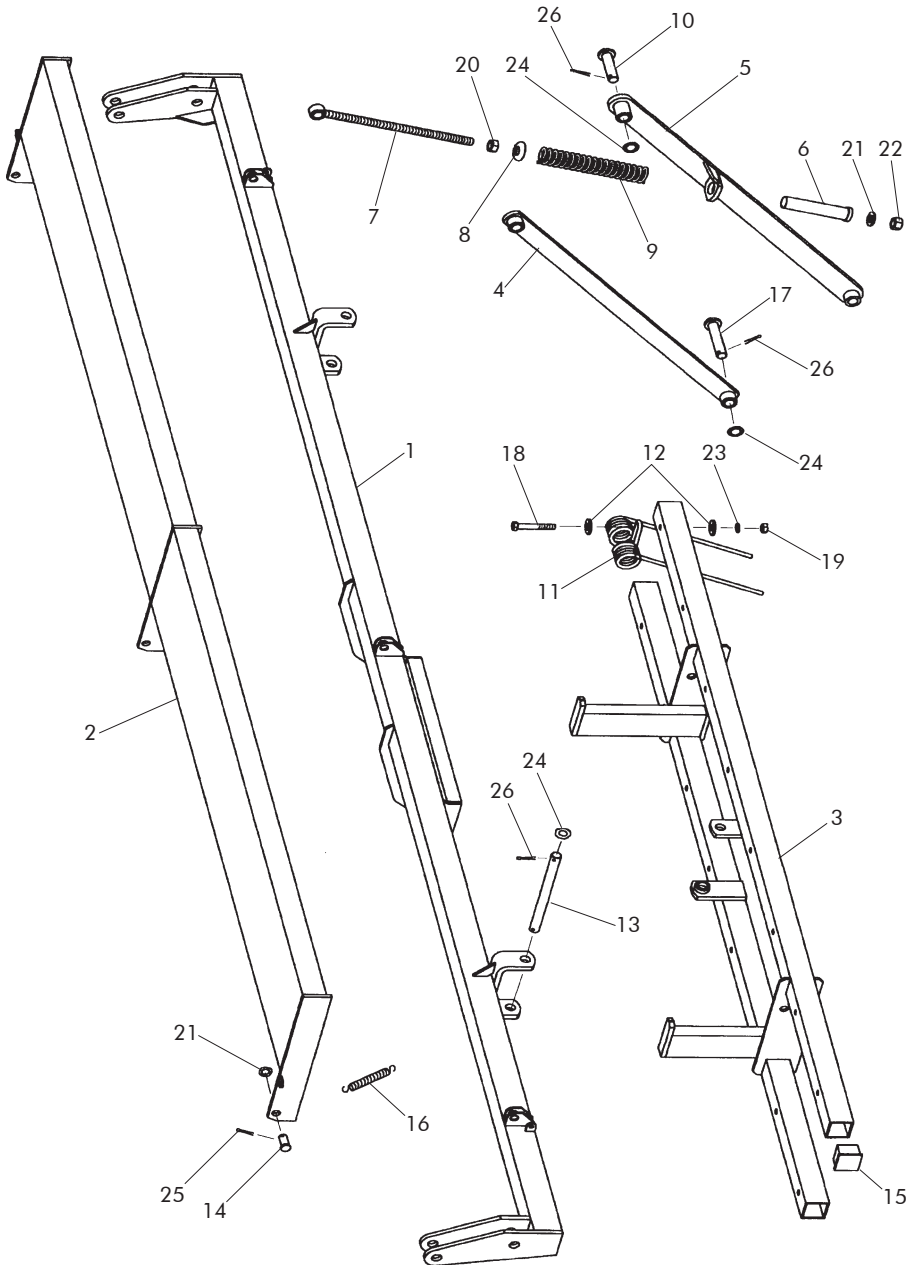

9.11 BRAZO BORRAHUELLAS «RANSOME»

<i>FIGURA</i>	<i>CÓDIGO</i>	<i>DENOMINACIÓN</i>
1	PS-1105/D	BRAZO BORRAHUELLAS CON TACO DERECHA
2	PS-1105/I	BRAZO BORRAHUELLAS CON TACO IZQUIERDA
3	FO-060300	REJITA DE 57X7
4	608/934 9X40	TORNILLO DE ARADO DIN 608 M-9X40 CON TUERCA
5	EE-060307	BRIDA SUJECIÓN BRAZO BORRAHUELLAS
6	PX-060200	PLETINA BRIDA BORRAHUELLAS
7	933 12X35 8.8 B	TORNILLO DIN 933 M-12X35 8.8 BICROMATADO
8	93412 BI	TUERCA DIN 934 M-12 BICROMATADA
9	CO-060200	TENSOR DE APRIETE CORTO
10	933 12X40 8.8 B	TORNILLO DIN 933 M-12X40 8.8 BICROMATADO

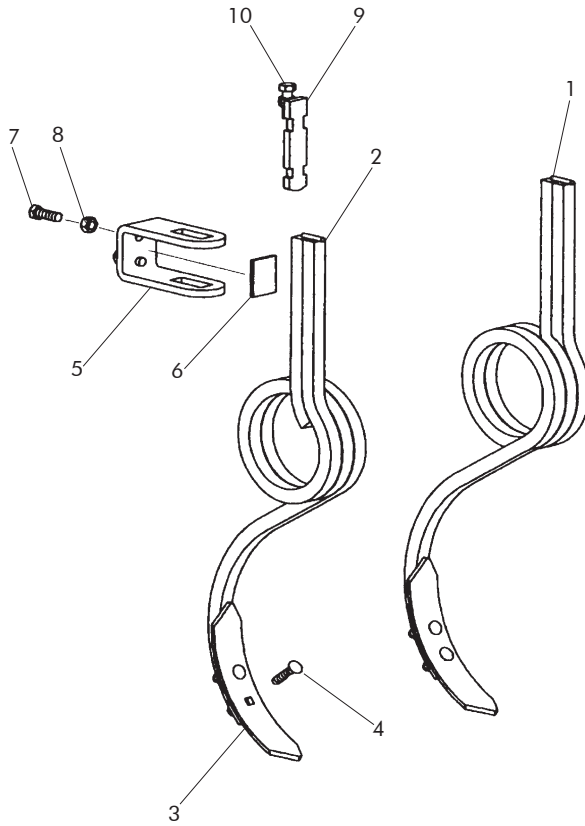

9.12 RASTRILLA ED-1003 CONTROL PROFUNDIDAD

FIGURA	CODIGO	DENOMINACION
1	PS-1739	BARRAS RASTRA 400 EPI 6
2	931 10X70 8.8B	TORNILLO DIN 931 M10x70 8.8 BI
3	PS-080902	SOPORTE RASTRA Y PELDAÑO
4	PS-081605-I	BRAZO MOTRIZ RASTRA ED RUEDAS TRAS.
5	933 10X60 8.8 B	TORNILLO DIN 933 M10x60 8,8 BI
6	ME-083200	BULON ARTICULACION PELDAÑ RASTRA XS
7	PS-081604	BRAZO TENSOR RASTRA CON RUEDAS TRAS
8	PS-080907	ESCALON PEQUEÑO ANCHO MAQ. 4000
9	PS-080903	SOPORTE RASTRA
10	PS-080905	ESCALON TODO ANCHO 4000
11	M01-83	MUELLE DOBLE PUA TRASERA -888
12	CN-817001	TAPON CUADRADO TUBO 50X50
13	PS-081605-D	BRAZO MOTRIZ RASTRA ED RUEDAS TRAS.
14	933 12X45 8.8B	TORNILLO DIN 933 M12x45 8,8 BI
15	127 12 BI	ARANDELA GROWER DIN 127 12 BI
16	BU-080206	BULON Ø16x37 DEL PELDAÑO RASTRA
17	ML-080101	MUELLE PELDAÑO RASTRA
18	931 12X80 8.8 BI	TORNILLO DIN 931 M12X80 8.8
19	9021 12 BI	ARANDELA DIN 9021 12 BI
20	985 10	TUERCA DIN 985 M10
21	PS-1710	TENSOR MUELLE RASTRA EPI
22	B03-177	BULON LARGO 20X78 DEL RASTRILLO
23	125 20 BI	ARANDELA DIN 125 M20 BI
24	125 16 BI	ARANDELA DIN 125 M16 BI
25	125 12 BI	ARANDELA DIN 125 M12 BI
26	125 10 BI	ARANDELA DIN 125 M10 BI
27	94 5x25 BI	PASADOR CON ALETAS DIN 94 M 5X25
28	985 12	TUERCA DIN 985 M12
29	934 12 BI	TUERCA DIN 934 M12 BI
30	CT-080904	CASQUILLO SEPARADOR ESCALON 300/400



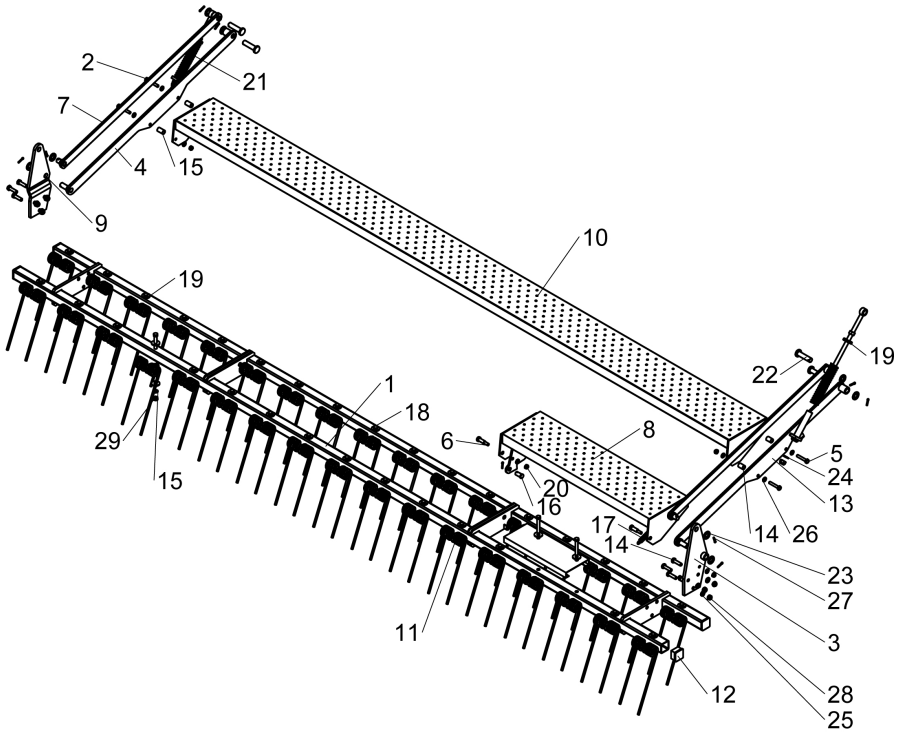

9.13 BRAZO BORRAHUELLAS «MUELLE»

<i>FIGURA</i>	<i>CÓDIGO</i>	<i>DENOMINACIÓN</i>
1	PX-060201	REFUERZO CORTO SOPORTE BRAZO BORRAHUELLAS BM
2	EE-060228	BRIDA BRAZO BORRAHUELLAS BM
3	PS-1113	SOPORTE BRAZO BORRAHUELLAS BM
4	EE-050312	TORNILLO DEL SOPORTE M-20/150X85
5	PL-050302	CASQUILLO ARTICULACIÓN BRAZO
6	FO-060202	TENSOR MUELLE BRAZO BORRAHUELLAS Y CULTIVADOR
7	BU-060300	BULÓN Ø12X69
8	ML-060300	MUELLE DEL BRAZO BORRAHUELLAS Y CULTIVADOR
9	PS-1120	BASTIDOR BRAZO BORRAHUELLAS BM CON TACO
10	FO-060302	BRAZO CORTO PARA BORRAHUELLAS BM
11	FO-060300	REJITA DE 57X7
12	608/934 9X40	TORNILLO DE ARADO DIN 608 M-9X40 CON TUERCA
13	93110X45 8.8 B	TORNILLO DIN 931 M-10X45 8.8 BICROMATADO
14	93410	TUERCA DIN 934 M-10
15	RE-060300	BRAZO BORRAHUELLAS BM COMPLETO
16	PS-1115	ARANDELA TOPE MUELLE
17	125 20 BI	ARANDELA PLANA DIN 125 020 BICROMATADA
18	98520/150	TUERCA DIN 985 M-20/150
19	127 10	ARANDELA GROWER DIN 127 010
20	985 16	TUERCA DIN 985 M-16
21	980 14 BI	TUERCA DIN 980 M-14 BICROMATADA

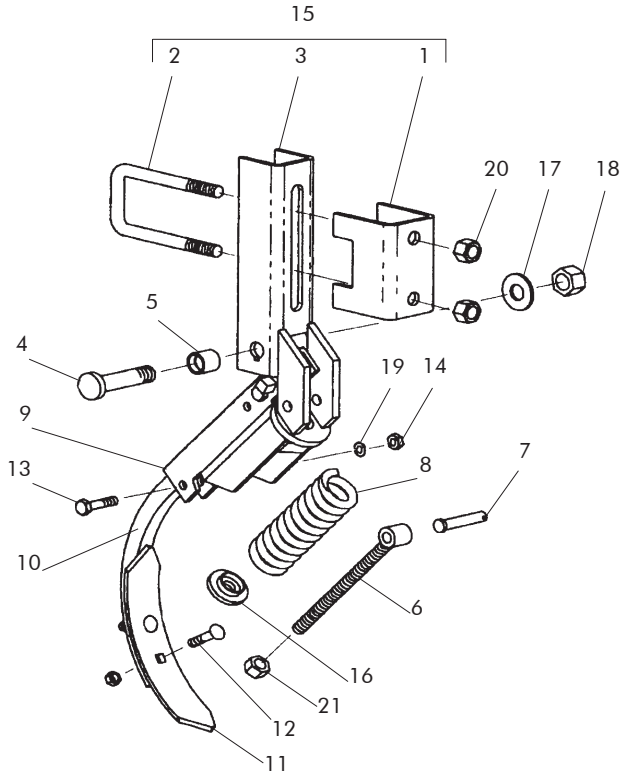

## 9.14 CULTIVADOR INTEGRADO

<i>FIGURA</i>	<i>CÓDIGO</i>	<i>DENOMINACIÓN</i>
1	PR-1201	BARRA CULTIVADOR EURO 250
1	PR-1202	BARRA CULTIVADOR EURO 300
1	PR-1203	BARRA CULTIVADOR EURO 350
1	PR-1204	BARRA CULTIVADOR EURO 400
2	EE-060207	BIELA CULTIVADOR
3	PS-1208/D	EXCÉNTRICA HUSILLO DERECHA
3	PS-1208/1	EXCÉNTRICA HUSILLO IZQUIERDA
4	PS-1207	HUSILLO CULTIVADOR
5	AD-070219	PLACA NUMERADA DEL GRADUADOR
6	PX-060213	HORQUILLA HUSILLO CULTIVADOR
7	ML-060702	CLIP «R» DEL HUSILLO CULTIVADOR
8	CO-070300	MANIVELA DEL HUSILLO
9	PS-1211	TUERCA DEL HUSILLO CON TUBO TELESCÓPICO INTERIOR
10	FO-060300	REJITA 57X7 MM
11	FO-060301	REJITA GOLONDRINA 135 MM
12	608/934 9X40	TORNILLO DE ARADO M-9X40 CON TUERCA HEXAGONAL
13	608/934 9X35	TORNILLO DE ARADO M-9X35 CON TUERCA HEXAGONAL
14	PS-1113	SOPORTE BRAZO BORRAHUELLAS MUELLE
15	PS-1117	SOPORTE BRAZO CULTIVADOR MUELLE
16	PS-1120	BASTIDOR BRAZO BORRAHUELLAS MUELLE CON TACO
17	PS-1121	BASTIDOR BRAZO CULTIVADOR MUELLE CON TACO
18	EE-060229	BRIDA BRAZO CM 100X50
19	PX-060203	REFUERZO SOPORTE BRAZO CM 100X50
20	FO-060303	BRAZO CULTIVADOR CON MUELLE
21	FO-060302	BRAZO BORRAHUELLAS CON MUELLE
22	ML-060300	MUELLE BRAZO BM Y CM
23	FO-060202	TENSOR MUELLE BRAZO BM Y CM
24	PS-1115	ARANDELA TOPE MUELLE
25	EE-050312	TORNILLO DEL SOPORTE M-20/150X85

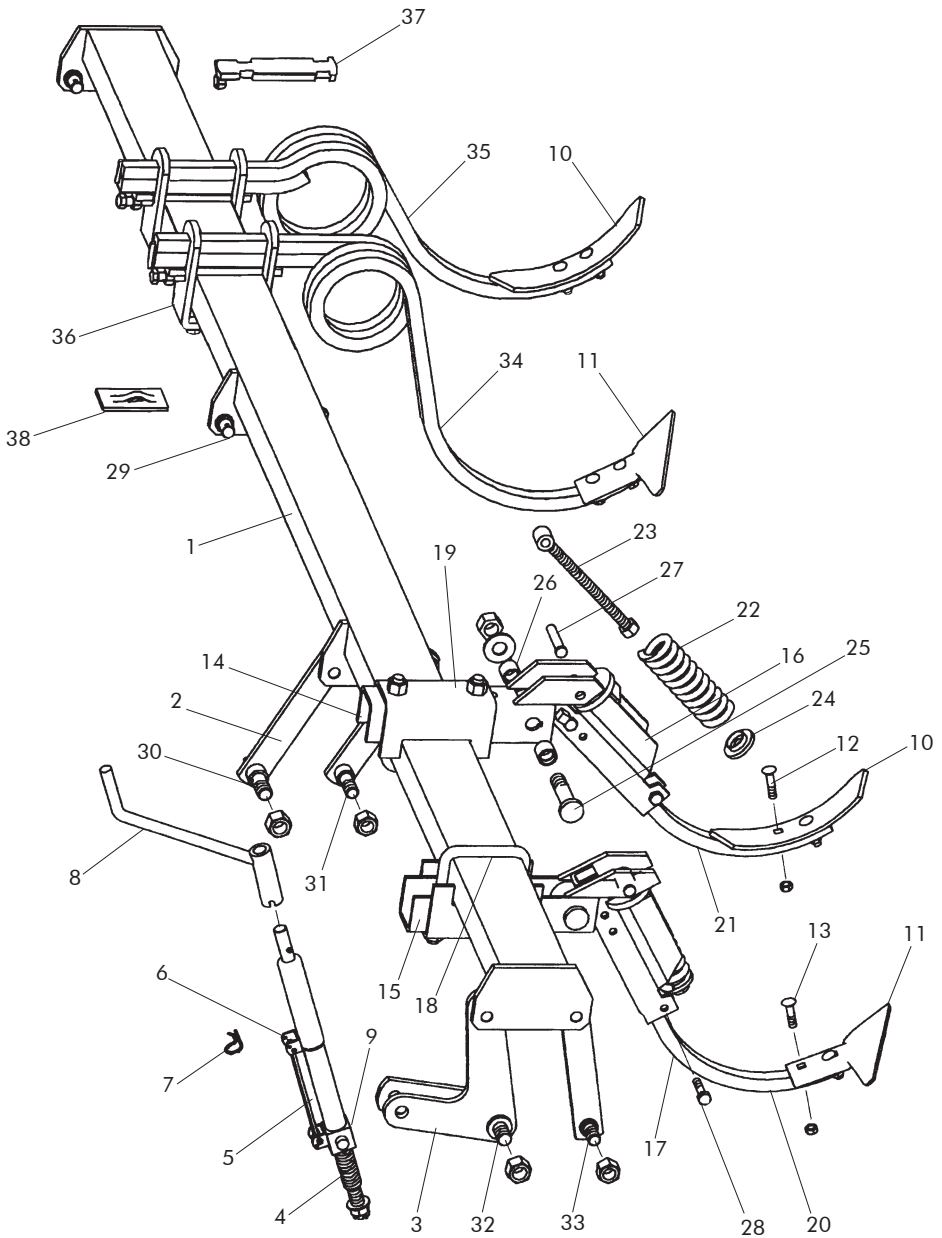

9.14 CULTIVADOR INTEGRADO

<i>FIGURA</i>	<i>CÓDIGO</i>	<i>DENOMINACIÓN</i>
26	PL-050302	CASQUILLO ARTICULACIÓN BRAZO
27	BU-060300	BULÓN 012X69
28	931 10X45 8.8 B	TORNILLO DIN 931 M-10X45 8.8 BICROMATADO
29	BU-060206	BULÓN SOLDABLE BIELA
30	BU-060209	BULÓN BIELA ENGANCHE M-20
31	BU-060208	BULÓN BIELA ENGANCHE M-18
32	BU-060204	BULÓN EXCÉNTRICA HUSILLO CULTIVADOR
33	BU-060207	BULÓN BIELA ROSCADO
34	PS-1209/D	BRAZO CULTIVADOR CON TACO DERECHA
34	PS-1209/1	BRAZO CULTIVADOR CON TACO IZQUIERDA
35	PS-1105/D	BRAZO BORRAHUELLAS CON TACO DERECHA
35	PS-1105/1	BRAZO BORRAHUELLAS CON TACO IZQUIERDA
36	EE-060226	BRIDA CULTIVADOR 100X50
37	CO-060202	TENSOR DE APRIETE LARGO
38	EE-060202	PLETINA BRIDA CULTIVADOR 100X50

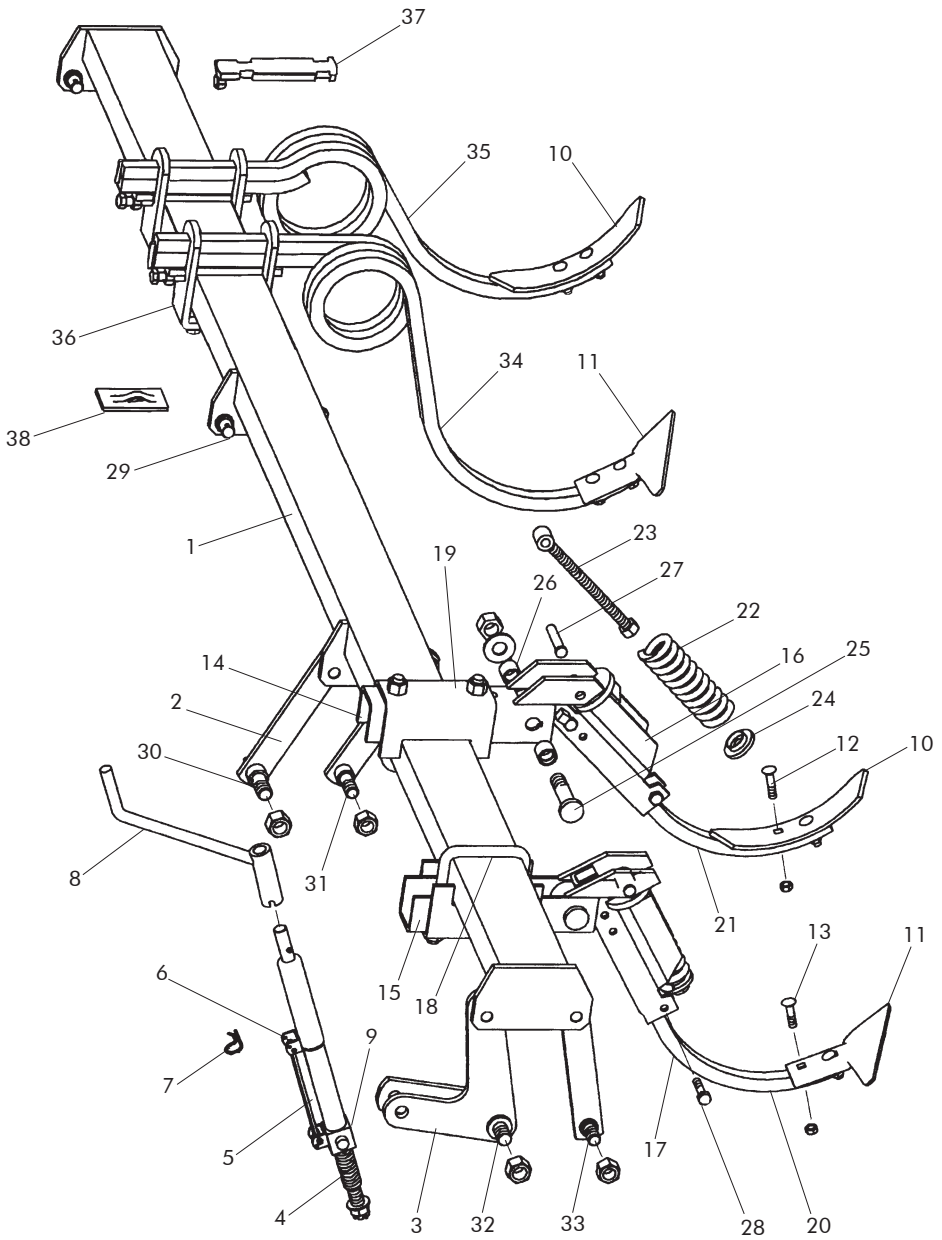

## 9.15 CULTIVADOR FLOTANTE

<i>FIGURA</i>	<i>CÓDIGO</i>	<i>DENOMINACIÓN</i>
1	PS-0705/6/7/8	CHASIS CULTIVADOR FLOTANTE 250/300/350/400
2	PS-060900	AMARRE TENSOR TERCER PUNTO CF EURO GC
3	PS-0701/D	BIELA ENGANCHE CF EURO DERECHA
3	PS-0701/I	BIELA ENGANCHE CF EURO IZQUIERDA
4	PS-0712/D	GATILLO ENGANCHE CF CON CLIP, DERECHA
4	PS-0712/I	GATILLO ENGANCHE CF CON CLIP, IZQUIERDA
5	PS-0709	AMARRE TENSOR TERCER PUNTO CF EURO
6	PS-0719	TENSOR TERCER PUNTO CF EURO
7	BU-060205	BULÓN BIELA ENGANCHE SOLDABLE
8	ML-010101	MUELLE GATILLO ENGANCHE
9	PS-0109	BARRA ENGANCHE EURO CATEGORÍA II
10	BU-060203	BULÓN Ø25X125
11	BU-060202	BULÓN Ø28X115
12	BU-060201	BULÓNØ20X115
13	PX-060202	REFUERZO MEDIANO SOPORTE BRAZO BM PARA CF
14	EE-060230	BRIDA BRAZO CULTIVADOR FLOTANTE M
15	EE-060227	BRIDA BRAZO CULTIVADOR FLOTANTE R
16	CO-060201	TENSOR DE APRIETE MEDIANO
17	PS-1117	SOPORTE BRAZO CULTIVADOR CM
18	PS-1113	SOPORTE BRAZO BORRAHUELLAS BM
19	VA-060200/D	BRAZO BORRAHUELLAS R SIN TACO DERECHA
19	VA-060200/I	BRAZO BORRAHUELLAS R SIN TACO IZQUIERDA
20	VA-060201/D	BRAZO CULTIVADOR R SIN TACO DERECHA
20	VA-060201/I	BRAZO CULTIVADOR R SIN TACO IZQUIERDA
21	FO-060303	BRAZO LARGO PARA CULTIVADOR CM
22	FO-060302	BRAZO CORTO PARA BORRAHUELLAS BM
23	PS-1121	BASTIDOR BRAZO CULTIVADOR CM CON TACO
24	PS-1120	BASTIDOR BRAZO BORRAHUELLAS BM CON TACO
25	FO-060301	REJITA GOLONDRINA 135 MM



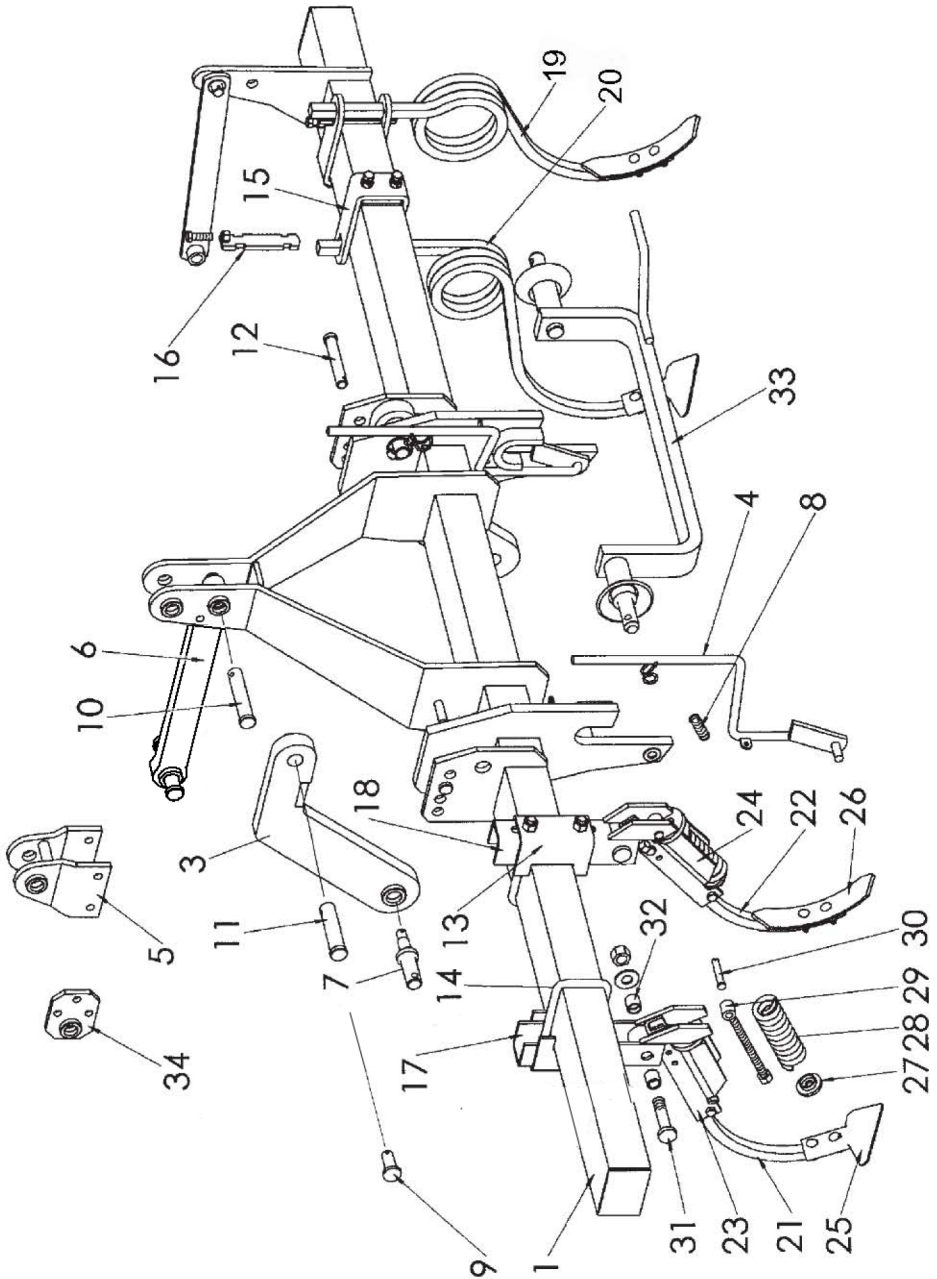

## 9.15 CULTIVADOR FLOTANTE

<i>FIGURA</i>	<i>CÓDIGO</i>	<i>DENOMINACIÓN</i>
<b>26</b>	FO-060300	REJITA 57X7 MM
<b>27</b>	PS-1115	ARANDELA TOPE MUELLE
<b>28</b>	ML-060300	MUELLE BRAZO BORRAHUELLAS Y CULTIVADOR
<b>29</b>	FO-060202	TENSOR MUELLE BRAZO BORRAHUELLAS Y CULTIVADOR
<b>30</b>	BU-060300	BULÓN Ø12X69
<b>31</b>	EE-050312	TORNILLO DEL SOPORTE M-20/150
<b>32</b>	PL-050302	CASQUILLO ARTICULACIÓN BRAZO

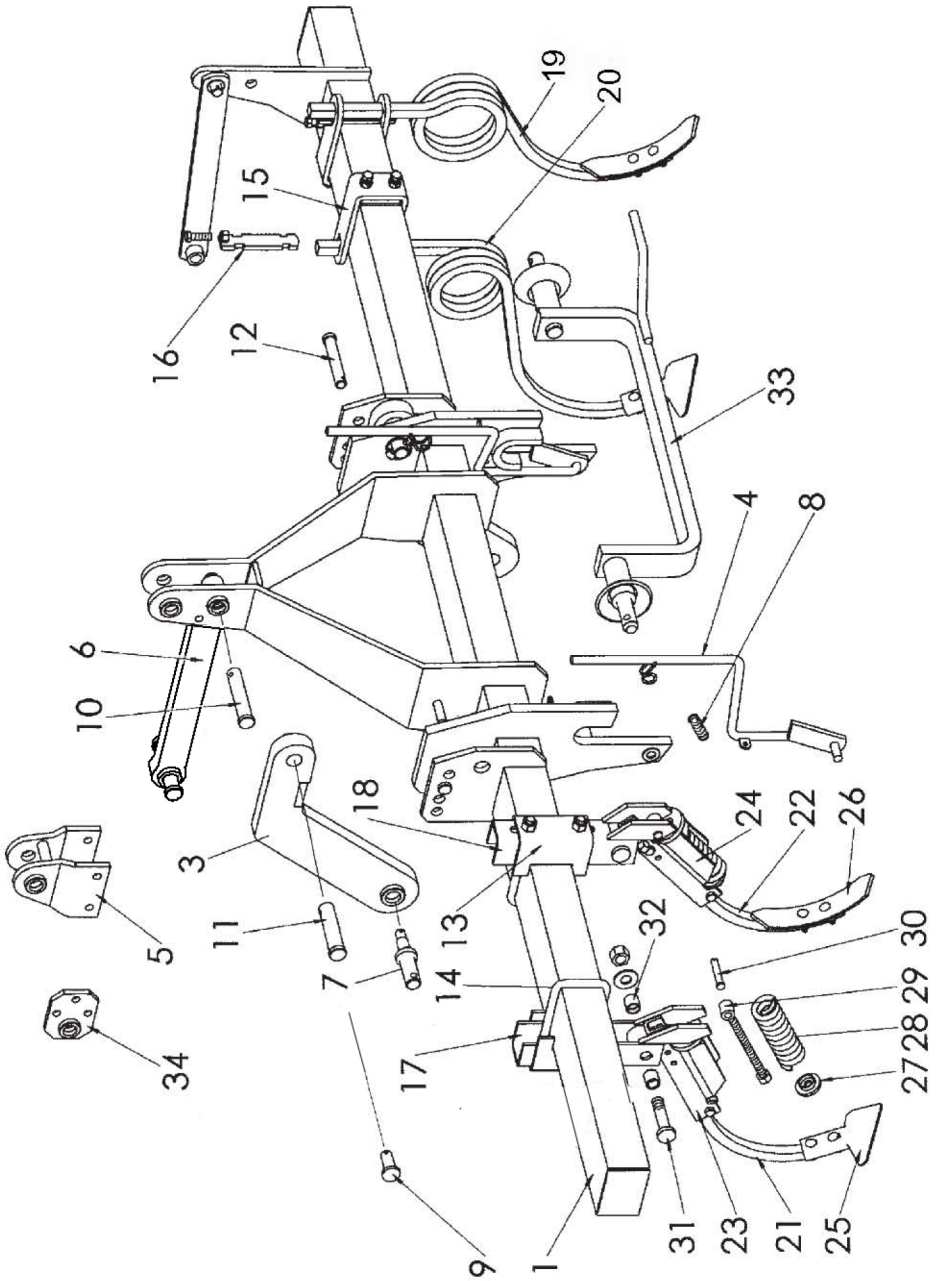

9.16 DOBLE BARRA NIVELADORA LISA Y A PÚAS

<i>FIGURA</i>	<i>CÓDIGO</i>	<i>DENOMINACIÓN</i>
1	ML-060701	MUELLE NIVELADOR
2	PS-0806	HUSILLO 1" NIVELADOR EURO
3	ME-060206	CASQUILLO GUÍA MUELLE NIVELADOR
4	ME-060201	ARANDELA HUSILLO NIVELADOR
5	931 W1"BI	TUERCA ALMENADA DIN 935 W1" BICROMATADA
6	PS-0807	HORQUILLA HUSILLO NIVELADOR EURO
7	PS-0901/2/3/4/D	BARRA INTERMEDIA EURO 250/300/350/400 DERECHA
7	PS-0901/2/3/4/I	BARRA INTERMEDIA EURO 250/300/350/400 IZQUIERDA
8	PS-0814	MANIVELA LARGA HUSILLO
9	BU-050301	BULÓN 016X47 ESTAMPADO
10	ML-060700	MUELLE DOBLE PÚA BARRA INTERMEDIA
11	9021 12 BI	ARANDELA DIN 9021 M12 BICROMATADA

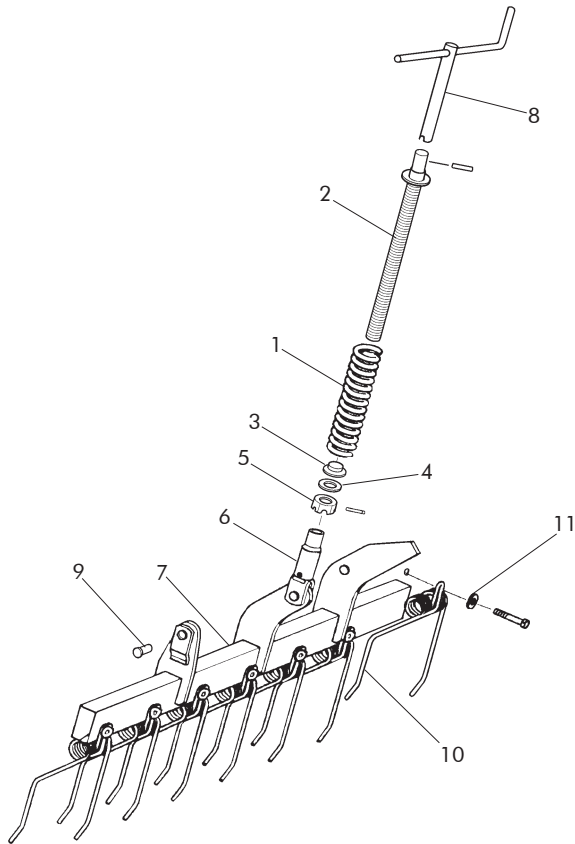

## 9.17 CUENTA HECTÁREAS

<i>FIGURA</i>	<i>CÓDIGO</i>	<i>DENOMINACIÓN</i>
1	PL-100200	BASE CAJA CUENTA-HECTÁREAS
2	TA-100102	CAJA CUENTA-HECTÁREAS
3	PL-100201	TAPA NEGRA CUENTA-HECTÁREAS
4	MV-100200	CONTADOR CINCO CIFRAS + 0
5	PL-100100	PIÑÓN CONDUCIDO DE 63Z PARA MÁQUINA DE 250
5	PL-100101	PIÑÓN CONDUCIDO DE 59Z PARA MÁQUINA DE 300
5	PL-100102	PIÑÓN CONDUCIDO DE 57Z PARA MÁQUINA DE 350
5	PL-100103	PIÑÓN CONDUCIDO DE 54Z PARA MÁQUINA DE 400
6	PL-100104	PIÑÓN MOTRIZ DE 30Z PARA MÁQUINA DE 250
6	PL-100105	PIÑÓN MOTRIZ DE 34Z PARA MÁQUINA DE 300
6	PL-100106	PIÑÓN MOTRIZ DE 36Z PARA MÁQUINA DE 350
6	PL-100107	PIÑÓN MOTRIZ DE 39Z PARA MÁQUINA DE 400
7	ME-100211	TORNILLO SUJECIÓN CUENTA-HECTÁREAS
8	7971 7X3/8 BI	TORNILLO ROSCA CHAPA DIN 7971 7X3/8" BICROM.
9	125 20 BI	ARANDELA PLANA DIN 125 020 BICROMATADA
10	94 3,5X28 BI	PASADOR ALETAS DIN 94 03,5X28 BI

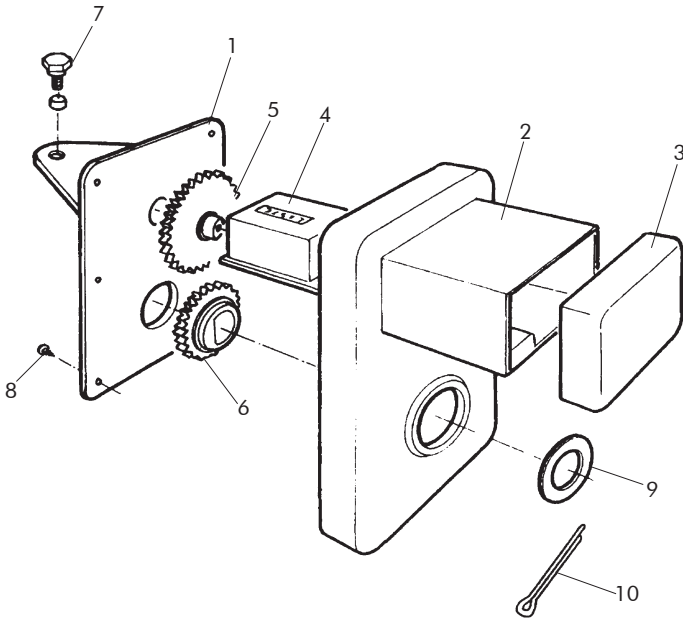

9.18 TRAZADORES DE DISCO

<i>FIGURA</i>	<i>CÓDIGO</i>	<i>DENOMINACIÓN</i>
1	EE-100217	DISCO BRAZO TRAZADOR, 3 AGUJEROS
2	RE-100200	BUJE COMPLETO, CON EJE Y RODAMIENTOS
3	PR-100201	EJE DISCO TRAZADORES
4	FE-601000	RETÉN DOBLE LABIO 025X052X7
5	ME-100214	BUJE DISCO
6	FE-600005	RODAMIENTO 6304 2RS
7	93516 BI	TUERCA ALMENADA DIN 935 M-16 BICROMATADA
8	PS-1803/D	BRAZO TRAZADOR 250/300/350 DERECHA
8	PS-1815/D	BRAZO TRAZADOR 400 DERECHA
8	PS-1815/I	BRAZO TRAZADOR 400 IZQUIERDA
9	PS-101303/D	SOPORTE BRAZO TRAZADOR DERECHA
9	PS-101303/I	SOPORTE BRAZO TRAZADOR IZQUIERDA
10	PS-101304	EJE ARTICULACIÓN BRAZO TRAZADOR
11	ML-050201	MUELLE DEL BRAZO CORTO
12	EE-100219	TENSOR MUELLE BRAZO TRAZADOR
13	PS-1805	PLETINA AMARRE MUELLE
14	ME-100200	ANILLO ARTICULACIÓN TENSOR
15	CO-100200	CILINDRO S.E. BRAZO TRAZADOR 888ATRI
16	MO-100111	MANDO CENTRAL MECÁNICO COMPLETO EURO
17	PS-1809	SOPORTE MANDO CENTRAL MECÁNICO TRAZADOR EURO
18	PS-1810	PALANCA MANDO CENTRAL TRAZADORES MECÁNICOS
19	ML-100700	MUELLE MANDO CENTRAL MECÁNICO
20	PS-1812/D	SUPLEMENTO BRAZO TRAZADOR MECÁNICO DERECHA
20	PS-1812/I	SUPLEMENTO BRAZO TRAZADOR MECÁNICO IZQUIERDA
21	EE-030200	ARANDELA 030 CON AGUJERO DE 08,5 BICROM.
22	12516BI	ARANDELA PLANA DIN 125 016 BICROMATADA
23	94 3,5X28 BI	PASADOR ALETAS DIN 94 03,5X28 BICROMATADO
24	CT-100800	SEPARADOR BUJE TRAZADORES



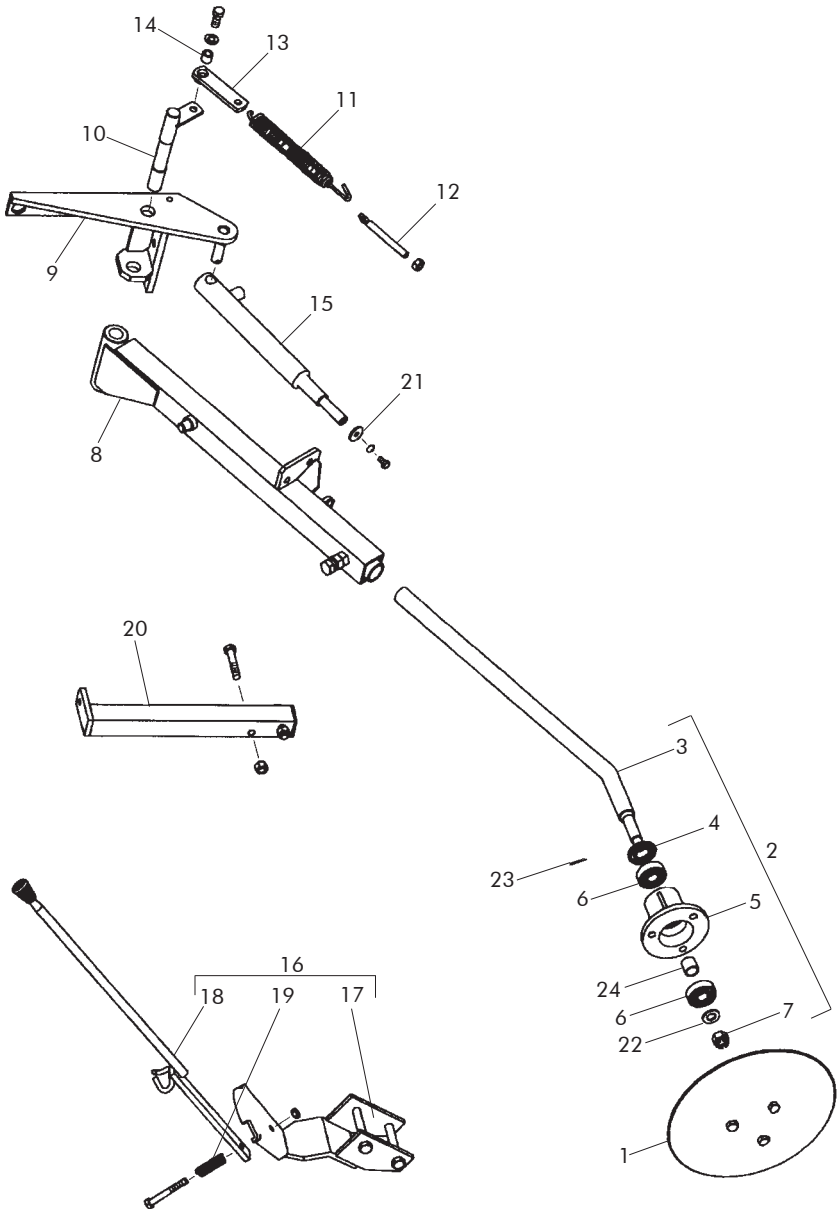

## 9.19 ENGANCHE AUTOMÁTICO

<i>FIGURA</i>	<i>CÓDIGO</i>	<i>DENOMINACIÓN</i>
1	OX-100203	BOCA DE ENGANCHE, SUELTA
2	ME-100206	SEPARADOR EA CORTO (MÁQUINAS 250 Y 300)
2	ME-100207	SEPARADOR EA LARGO (MÁQUINAS 350 Y 400)
3	ME-060207	CASQUILLO GIRATORIA EA
4	9021 12 BI	ARANDELA DIN 9021 M12 BICROMATADA
5	BU-010100	BULÓN BARRA ENGANCHE CATEGORÍA II
6	EE-010226	TOPE CÓNICO BARRA ENGANCHE

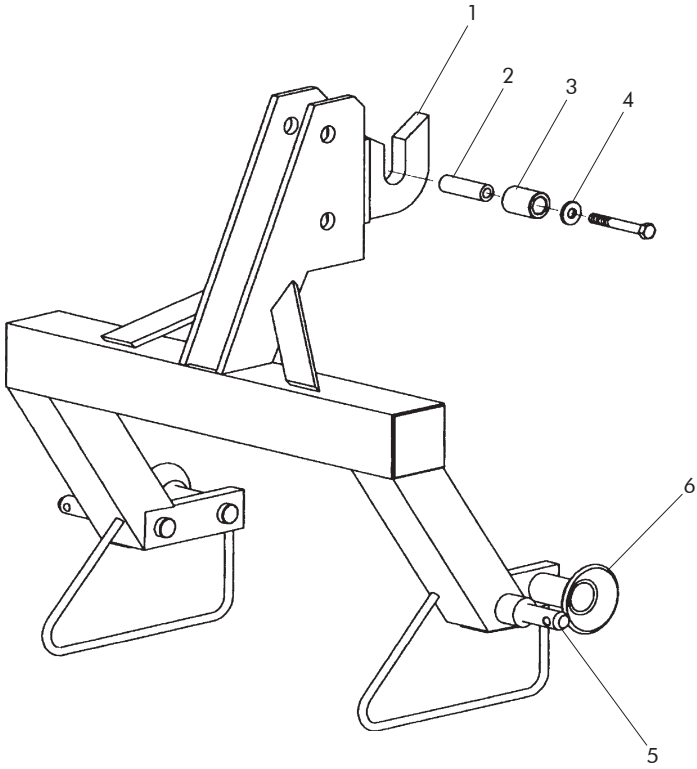

## 9.20 ENGANCHE AUTOMÁTICO PARA CULTIVADOR FLOTANTE

<i>FIGURA</i>	<i>CÓDIGO</i>	<i>DENOMINACIÓN</i>
1	PS-100202	ENGANCHE AUTOMÁTICO PARA CULTIVADOR FLOTANTE
2	PS-100201	TENSOR TERCER PUNTO
3	ME-060209	CASQUILLO SUPERIOR TENSOR TERCER PUNTO
4	9021 12 BI	ARANDELA DIN 9021 M12 BICROMATADA
5	OX-100203	BOCA DE ENGANCHE, SUELTA
6	BU-010100	BULÓN BARRA ENGANCHE CATEGORÍA II
7	EE-010226	TOPE CÓNICO BARRA ENGANCHE
8	93314X40 8.8 B	TORNILLO DIN 933 M-14X40 8.8 BICROMATADO

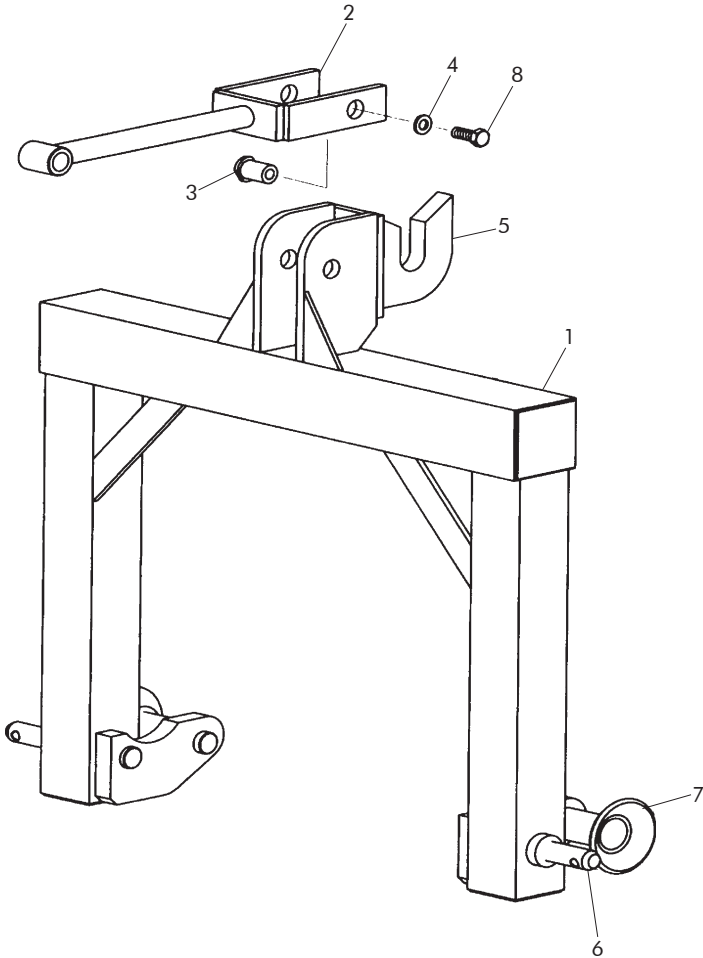

9.21 ACABADOS

<i>FIGURA</i>	<i>CÓDIGO</i>	<i>DENOMINACIÓN</i>
1	PS-0609	SOPORTE MANDO HIDRÁULICO VARIADOR ABONO
2	PS-0608	SOPORTE MANDO HIDRÁULICO VARIADOR SEMILLA
3	CO-100201	CILINDRO EMBRAGUE VARIADOR
4	EE-030202	ARANDELA 030X10,5X3 BICROMATADA
5	ME-100202	ANILLO TOPE CILINDRO VARIADOR
6	PS-0607	TORNILLO TOPE CILINDRO VARIADOR
7	ME-100210	ESTRANGULADOR CILINDRO
8	BU-100204	BULÓN ROSCADO CILINDRO VARIADOR
9	EE-010200	ARANDELA SUPLEMENTO BUJE RUEDA
10	CO-040301	SEPARADOR CORTO BUJE (40 MM)
11	MO-1637	ALOJAMIENTO MANIVELA RUEDA CON PASADOR
12	CO-070300	MANIVELA HUSILLOS
13	AD-070227	ADHESIVO «PARAR MOTOR»
14	AD-070206	ADHESIVO «LEER LIBRO DE INSTRUCCIONES»
15	AD-070214	ADHESIVO «PELIGRO, MANIOBRA DE ENGANCHE»
16	AD-070207	ADHESIVO «PELIGRO DE APLASTAMIENTO»
17	AD-070215	ADHESIVO «PELIGRO DE CAÍDA»
18	AD-070222	ADHESIVO «PELIGRO HIDRÁULICO»
19	AD-100200	ADHESIVO «ATENCIÓN TRAZADORES»
20	AD-030200	ADHESIVO «PELIGRO AGITADOR»

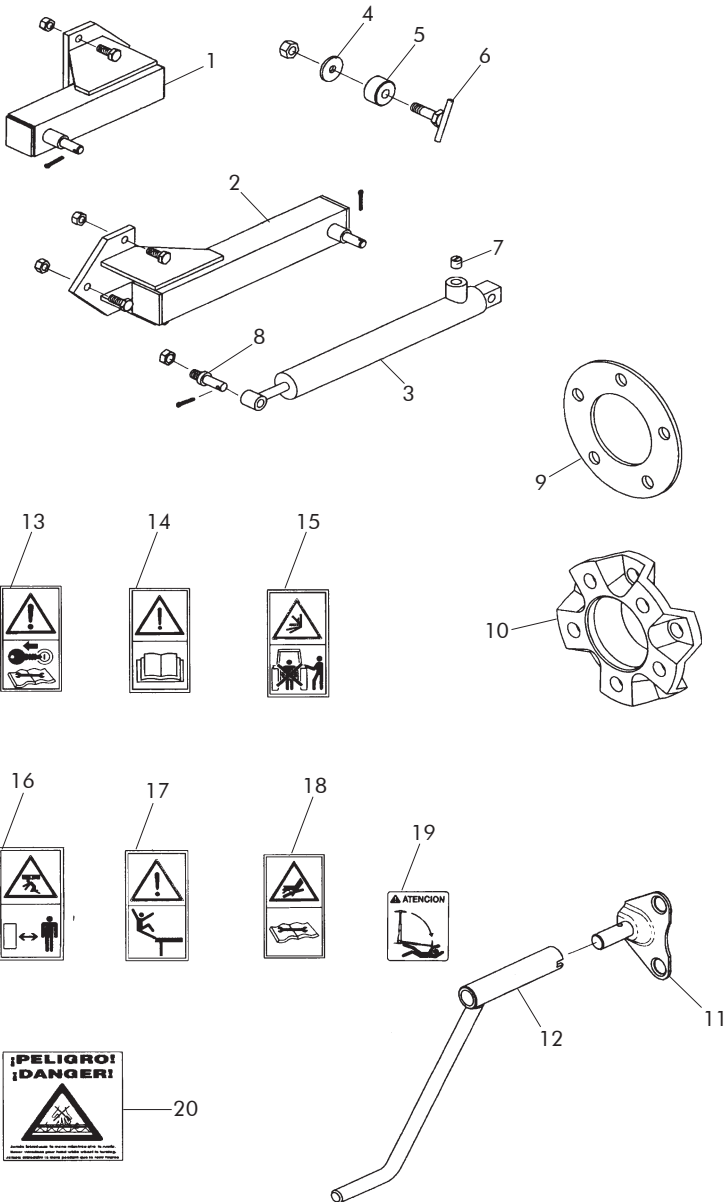









**MAQUINARIA AGRÍCOLA SOLÁ, S.L.**  
**Ctra. de Igualada, s/n. Apdo. Correos, 11**  
**08280 CALAF (Barcelona) ESPAÑA**  
**Tel. 34 93 868 00 60\***  
**Fax. 34 93 868 00 55**  
**[www.solagrupo.com](http://www.solagrupo.com)**  
**e-mail:[sola@solagrupo.com](mailto:sola@solagrupo.com)**