



seed drill

TRISEM and TRICOMBI



194/R - 294/R

294/R ESP

**STARTING MANUAL
MAINTENANCE
DOSAGE
SPARE PARTS**

read carefully this booklet before operating the machine

Ref.: CN-811003

12ª Edition - 05-2010

It is forbidden the total and partial reproduction

We can modify the specifications without prior notice

Seed drills and Fertilizer Spreadrs SOLA are produced in a factory particularly specialized in this kind of machines and they are guaranteed for the experience of the users.

They are machines based on state-of-the-art technology and the are manufactured with recognized safety requirements for doing an excellent work with a minimal maintenance.

The purpose of this operating manual is to enable you to familiarise yourself with the working of your seed drill and to achieve your purposes.



Quality certificate

TABLE OF CONTENTS

| | |
|--|----|
| 1. INTRODUCTION | 4 |
| 2. TECHNICAL SPECIFICATIONS | 5 |
| 3. SAFETY INSTRUCTIONS | 7 |
| 4. ESSENTIAL CONCEPTS FOR SOWING | 12 |
| 5. OPERATING | 16 |
| 5.1 Coupling | 16 |
| 5.2 Dispenser device | 17 |
| 5.3 Seed dosage | 18 |
| 5.4 Seed dosage test | 19 |
| 5.5 Land test | 21 |
| 5.6 Combined distribution | 22 |
| 5.7 Combined hopper | 22 |
| 5.8 Combined dosage | 23 |
| 5.9 Sowing arms adjustment | 25 |
| 5.10 Depth control | 26 |
| 5.11 Scrapers | 26 |
| 6. OPTIONAL EQUIPMENT..... | 27 |
| 6.1 Wheel breakers..... | 27 |
| 6.2 Leveler | 27 |
| 6.3 Harrow EPI-6 and EPI-7..... | 28 |
| 6.4 Harrow ESP | 29 |
| 6.5 Markers | 30 |
| 6.6 Hectare counter | 32 |
| 6.7 Cultivator | 33 |
| 6.8 Variator clutch | 34 |
| 7. MAINTENANCE | 35 |
| 8. DOSAGE TABLES | 39 |
| 9. SPARE PARTS..... | 47 |
| 9.1 Introduction | 47 |
| 9.2 Chassis..... | 49 |
| 9.3 Working device | 50 |
| 9.4 Seed variator | 52 |
| 9.5 Fertilizer variator..... | 54 |
| 9.6 Hopper. Combined seed drill | 56 |
| 9.7 Big capacity Hopper. Combined seed drill GC..... | 58 |
| 9.8 Combined seed drill. Distribution | 60 |
| 9.9 Markers | 62 |
| 9.10 Harrow EPI-6 | 64 |
| 9.11 Harrow EPI-7 | 66 |
| 9.12 Harrow ESP | 68 |
| 9.13 «Ransome» track erasers | 70 |
| 9.14 «Spring» track erasers | 70 |
| 9.15 Cultivator | 72 |
| 9.16 Leveler | 74 |
| 9.17 Hectare counter | 74 |
| 9.18 Automatic coupling | 76 |
| 9.19 Automatic coupling | 76 |
| 9.20 Finishing | 78 |

1. INTRODUCTION

Before any use of the machine it is very important to read the instructions and suggestions in this booklet, in order to reduce the danger of accidents and to prevent damages to the seed drill due to incorrect use or defective maintenance. You will increase its performance and useful life.

This booklet must be read by any operator of the machine, during its operation, repairs, maintenance and transport. It is an integrating part of the product, and must be kept in a safe place for consultation during the whole life span of the machine.

SOLÀ will not assume any responsibility for damages or breakdowns caused by non-observance of the instructions given in this booklet.

In the first chapters you will find the Technical Data and Safety Instructions, also some Essential Sowing Concepts. In the Rules of Use and Maintenance chapters are the basic knowledges for using the machine. The booklet is completed with a seed dosage table and Spare parts list.



SOLÀ reserves the right to modify drawings and technical data given in this manual if this can help to improve the seed-drill quality.

2. TECHNICAL SPECIFICATIONS

2.1 TRISEM-194/R - TRISEM-294/R

| TYPE ARMS | ARMS DISTANCE | WORK. WIDTH | TOTAL WIDTH | HOPPER CAPACITY | | HOP. (kg) | WHEELS |
|-----------|---------------|-------------|-------------|-----------------|-----|-----------|----------|
| | | | | LITRES | KGS | | |
| 250/19 | 13 cm | 2,50 m | 2,68 m | 540 | 390 | 680 | 6.00-16 |
| 300/22 | 13,5 cm | 3,00 m | 3,17 m | 665 | 480 | 760 | 6.00-16 |
| 350/25 | 14 cm | 3,50 m | 3,80 m | 790 | 570 | 830 | 10.80-12 |
| 400/28 | 14 cm | 4,00 m | 4,29 m | 920 | 660 | 910 | 10.80-12 |

2.2 TRICOMBI-194/R - TRICOMBI-294/R

| TYPE ARMS | ARMS DISTANCE | WORK WIDTH | TOTAL WIDTH | HOPPER CAPACITY LITRES | | HOPPER CAPAC. TRIGO FERT. | | WEIHT (kg) | WHEELS |
|-----------|---------------|------------|-------------|------------------------|---------|---------------------------|-------|------------|----------|
| | | | | WHEAT | FERTIL. | TRIGO | FERT. | | |
| 250/19 | 13 cm | 2,50 m | 2,68 m | 270 | 270 | 195 | 320 | 750 | 6.00-16 |
| 300/22 | 13,5 cm | 3,00 m | 3,17 m | 335 | 335 | 245 | 400 | 840 | 6.00-16 |
| 350/25 | 14 cm | 3,50 m | 3,80 m | 400 | 400 | 295 | 480 | 910 | 10.80-12 |
| 400/28 | 14 cm | 4,00 m | 4,29 m | 460 | 460 | 345 | 560 | 990 | 10.80-12 |

2.3 TRISEM-194/R-GC - TRISEM-294/R-GC

| TYPE ARMS | ARMS DISTANCE | WORK. WIDTH | TOTAL WIDTH | HOPPER CAPACITY | | WEIHT (kg) | WHEELS |
|-----------|---------------|-------------|-------------|-----------------|-----|------------|----------|
| | | | | LITRES | KGS | | |
| 300/22 | 13,5 cm | 3,00 m | 3,17 m | 826 | 625 | 931 | 10.80-12 |
| 350/25 | 14 cm | 3,50 m | 3,80 m | 1027 | 740 | 1060 | 10.80-12 |
| 400/28 | 14 cm | 4,00 m | 4,29 m | 1188 | 860 | 1155 | 10.80-12 |

2.4 TRICOMBI-194/R-GC - TRICOMBI-294/R-GC

| TYPES ARMS | ARMS DISTANCE | WORK. WIDTH | TOTAL WIDTH | HOPPER CAPAC. LITRES | | HOPPER CAP. LITRES | | WEIHT (kg) | NEUMÁTI |
|------------|---------------|-------------|-------------|----------------------|-----|--------------------|-----|------------|----------|
| | | | | WHEAT | | WHEAT | | | |
| 300/22 | 13,5 cm | 3,00 m | 3,17 m | 424 | 442 | 306 | 530 | 985 | 10.80-12 |
| 350/25 | 14 cm | 3,50 m | 3,80 m | 503 | 524 | 363 | 630 | 1100 | 10.80-12 |
| 400/28 | 14 cm | 4,00 m | 4,29 m | 582 | 606 | 420 | 725 | 1195 | 10.80-12 |

2.5 TRISEM-294/R-ESP

| TIPO Y BRAZOS | SEPARACIÓN BRAZOS | ANCHO LABOR | ANCHO TOTAL | CAPACIDAD TOLVA | | PESO (kg) | NEUMÁTICOS |
|---------------|-------------------|-------------|-------------|-----------------|-------|-----------|------------|
| | | | | LITROS | KILOS | | |
| 250/16 | 15,5 cm | 2,50 m | 2,68 m | 540 | 390 | 680 | 6.00-16 |
| 300/19 | 16 cm | 3,00 m | 3,17 m | 665 | 480 | 760 | 6.00-16 |
| 350/22 | 16 cm | 3,50 m | 3,80 m | 790 | 570 | 830 | 6.00-16 |
| 400/25 | 16 cm | 4,00 m | 4,29 m | 920 | 660 | 910 | 6.00-16 |

2.6 TRICOMBI-294/R-ESP

| TIPO Y BRAZOS | SEPARACIÓN BRAZOS | ANCHO LABOR | ANCHO TOTAL | CAPACIDAD TOLVA | | CAPACIDAD TOLVA | | PESO (kg) | NEUMÁTICOS |
|---------------|-------------------|-------------|-------------|-----------------|-------|-----------------|-------|-----------|------------|
| | | | | EN LITROS TRIGO | ABONO | EN KILOS TRIGO | ABONO | | |
| 250/19 | 15,5 cm | 2,50 m | 2,68 m | 270 | 270 | 195 | 320 | 750 | 6.00-16 |
| 300/22 | 16 cm | 3,00 m | 3,17 m | 335 | 335 | 245 | 400 | 840 | 6.00-16 |
| 350/25 | 16 cm | 3,50 m | 3,80 m | 400 | 400 | 295 | 480 | 910 | 6.00-16 |
| 400/28 | 16 cm | 4,00 m | 4,29 m | 460 | 460 | 345 | 560 | 990 | 6.00-16 |

2.7 STANDARD EQUIPMENT

- Seed variator
- Fertilizer variator (combined version)
- Seed dispensen roller (normal and small seed)
- «spring» sowing arms (194/R) three rows
- «ransome» sowing arms (294/R and 294/R-ESP) three rows
- Right coulters
- Sowing depth adjustment device
- Fast coupling
- Selecting sieve for fertilizer. Combined version
- Grain level
- Indicator for machine leveling
- Plate, weighing machine and grain counter (excepting types ESP)
- Hopper apron (excepting types ESP)
- Wheel scrapers (excepting types ESP)
- Set of lights (excepting types ESP)

2.8 OPTIONAL EQUIPMENT

- Double tube for combined machines
- Harrow with: flexible tines, step, types EPI-6 and EPI-7 (4 m)
- Harrow with flexible tines type ESP (only types ESP)
- «Ransome» wheel breakers
- «Spring» wheel breakers
- Hectare counter
- Disc markers
- Variator control
- Cultivator
- Central leveler
- Automatic coupling

3. SAFETY INSTRUCTIONS

3.1 SAFETY SIGNS

You will find, in this operating manual, three types of safety and danger symbol:



To facilitate operation with the seed drill.



To avoid damages on the machine or in the optional equipments.



This symbol warns of the risk of injury.

On the machine you will find the following symbols:

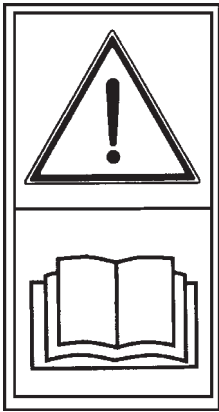

Please, read the safety instructions contained in this operation manual with care and also observe all warning signs



Stay away of the tractor back part during the coupling operation, during the manoeuvring
Danger of serious lesions



Stop the tractor engine and avoid its start during the maintenance or repairing works in the seed drill.
Consult operating manual.



Do not place under the sowing equipment or under swinging areas.
Danger of serious lesions



Do not ride on the seed drill stairs when the machine is working.



Supervise hydraulic pipes. Consult operating manual for service procedures. Danger of serious lesions.



Close the hopper cover with care. Do not place the hand into the hopper to avoid lesions.



Do not place under the track markers. **Danger of serious lesions.**



Respect the maximum weight



Handling point for lifting.



Do not place the hand into the hopper while the agitator shaft is turning. **Danger of lesions.**

3.2 USE

- Seed drills **TRI-194/R y TRI-294/R** have been manufactured for the agricultural works, specially for cereals sowing and the other grain sowing.
- SOLÀ can not be held liable for any consequential damage resulting from incorrect use, metering or distribution.
- All relevant accident prevention, as well as other generally acknowledged safety and road traffic regulations, must be observed.
- All the machine modifications realised by the user, automatically exempt SOLÀ from its/his liability in respect on ensuing damages.

3.3 SAFETY ARRANGEMENTS

- Before to start the machine it is very important to read the operation safety and road safety.
- Road traffic regulations and signs must be observed.
- It is strictly forbidden to ride on the machine during working and transport.
- Before starting, familiarize with all activation elements, as well as with general operation.
- Pay special attention during coupling and uncoupling operation.
- During the seed dosage test, pay attention to dangerous points, specially the agitator teeth inside the hopper and the wheel scrapers.
- The fast-coupling clamps must be unblocked during normal operation. They must be blocked only for uncoupling.

- Never leave the driver seat during machine operation.
- Do not place strange elements into the hopper.
- Before working on hydraulic system, leaves the machines on the floor, eliminate circuit pressure and stop the engine.
- The hydraulic system generates extremely high pressure. All piping, hoses and connections must therefore be checked regularly for leakage and visible external damage. Useful life for these elements is not more than six years. You must change them after this time.
- When the seed drill is raised, the tractor front axle discharges. Verify that the charge is enough to avoid lodging danger. In this situation, verify direction and braking capacity.
- During the transport with the seed drill raised, block the descent control. Before descending of the tractor, place the machine on the ground and remove starting keys.
- Be extremely careful when working with the machine in raised position. Use support elements to avoid a possible descent of the machine.

3.4 LOADING AND UNLOADING

It is necessary to load and to unload the truck, if it is possible, with a bridge crane. The drawings 1 and 2 show the towrope position for the operation and the fastening points: coupling and harrow-scraper support.

Pay attention with the operations. They must be done by responsible and experienced people.

To avoid serious damage, do not stay under the machine during the operation.

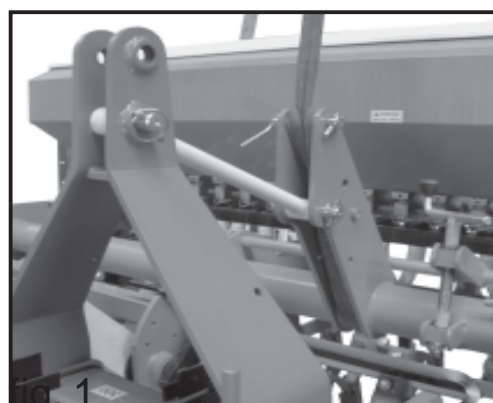
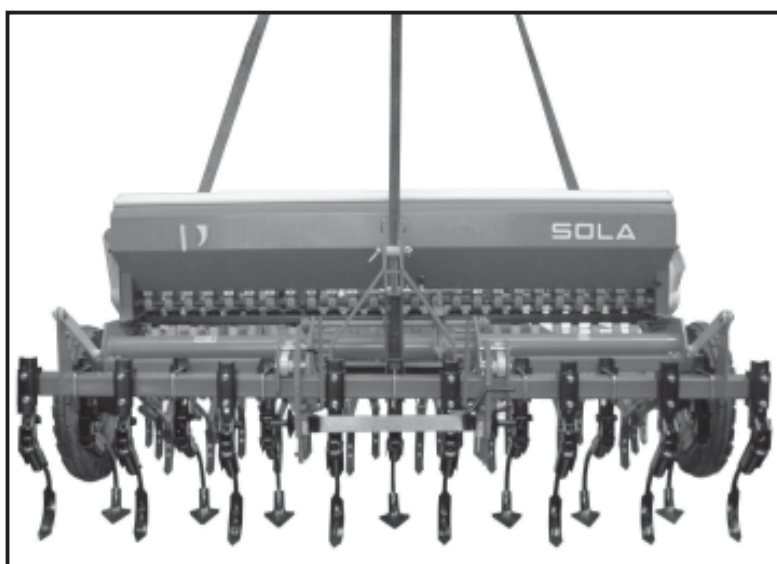
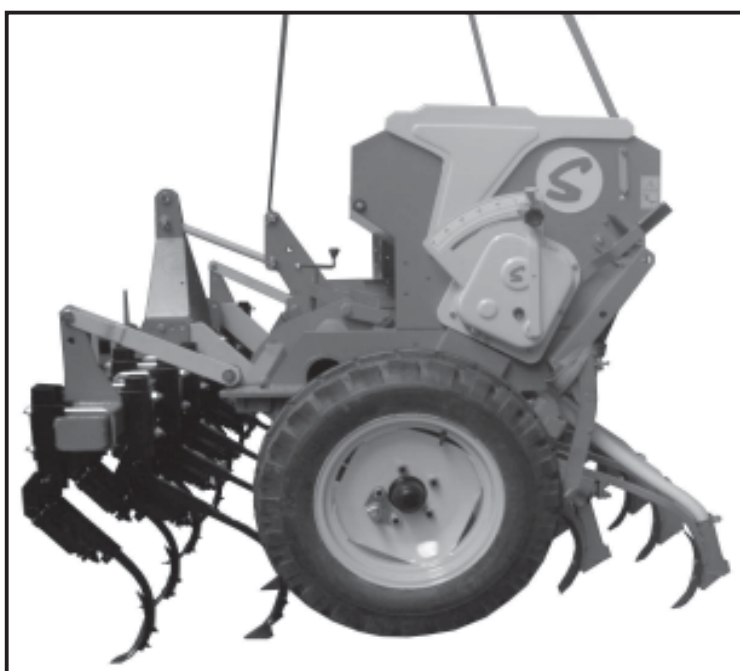

fig. 2



4. SOWING ESSENTIAL CONCEPTS

4.1 SOIL

To have the better quality of sowing, it is very important the soil condition. Over big patch or variable furrow it is not possible to do a good work. Although SOLÀ machines are able to take hard efforts in extreme conditions, sowing will have not good quality if the sowing land has not good conditions.

4.2 SEED

It is very important use quality and clean seed. When sowing barley, use trimmed one.

4.3 DEPTH

The suggested sowing depth is from three to five centimetres. To deepen more is an error, as the rizome could not get the surface, resulting in the plant's death. It does not matter if some grains are visible: the spring harrow will cover them.

Sowing depth has influence in the birth and vigour of the plant and consequently in its resistance to both frost and drought. The sprouting node will be always between 1 or 2 cm under the surface, independently of the sowing depth.

Deeper sowing does not mean deeper roots. Only a few roots arise from the bottom of the seed. The main root mass is born from the sprouting node, just under the ground level.

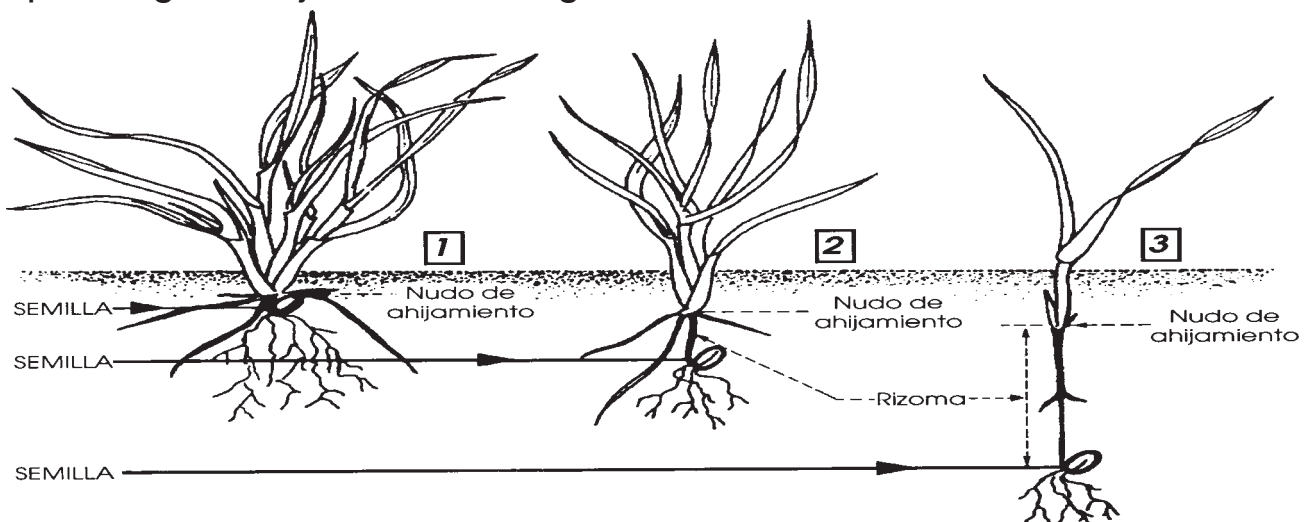

1

**Sowing depth
2 to 4 cm**

Thick stem, short rhizome,
good freezing endurance

Multiple sprouting, 3 to 6
shoots and a lot of blades
(6 to 10)

Big tuft of roots, 5 cm
wide and 10 to 12 cm
deep

With less grains per
square meter, we obtain
more ears

2

**Sowing depth
5 to 6 cm**

Thin stem, rhizome expo-
sed to freezing

Delayed and poor sprouting,
one shoot (sometimes none)
not many blades, 3 or 4

Medium tuft of roots, 3 cm
wide and 5 cm deep

We need more grains
per square meter to ob-
tain the same quantity
of ears as in the first case

3

**Sowing depth
8 to 10 cm**

Very thin stem. No sprou-
ting and a single blade

The grain reserves beco-
me depleted by forming a
large rhizome that can be
easily cutted off by ice

Poor tuft of roots, just 1 cm
wide and 3 cm deep

We need twice the grains
per square meter to ob-
tain the same quantity of
ears as in the first case



In very cold areas, successive frosts may cause soil sur-
face fluffing up, involving the risk of releasing the incipient
plant roots and causing its death.

To avoid this danger, it is recommendable to deepen
more the seed or to pass a roller in order to compact the
land after sowing



In all SOLÁ machines, the seed distributor speed
variator is activate by the right wheel.

Bends must be done counterclockwise, as turning
around the drive wheel will cause a lower distribution
of seed



Once the machine is working, seed will not be delivered
in the first groove meter. On the contrary, when the machine
stops, the remaining grain inside the pipes will slide down
and pile up.



Work always at a regular speed. Hard brakes and sudden
accelerations result in irregular seed distribution.

4.4 SEED DOSE ADJUSTMENT

With current use of high quality certificated seed, it is not enough to set the weight that has to be distributed by the seed drill, since the success of the harvest depends on the number of plants that reach complete ripeness.

Each plant requires its living space from which feeds on. In this way, as poor could be an high plant density as a low. To decide the adequate dose, we must know the number of plants per square meter we are going to sow.

Orientatively, the plant number recommended for wheat and barley in dry land is as follows:

| | | |
|---------|--------------|-------------------------------|
| AUTUMN: | Early sowing | 200 plants per m ² |
| | Late sowing | 265 plants per m ² |
| SPRING: | Early sowing | 310 plants per m ² |
| | Late sowing | 445 plants per m ² |

Notice that, in spring, sprouting is always lower and, consequently, more seed is needed to obtain the same results that in autumn.



MAQUINARIA AGRÍCOLA SOLÀ, S.L., thinks that is recommendable to seed advice about recommended dosification in some technical sowing center



The seed dose must be adjusted to each soil depending on its texture, fertilization level, dampness an sowing time, grain quality, germinative value, etc.

Moreover, it must be took into account that the maximum germinative value is variable and depends on a lot of factors. Experimentally, it can be established between 70% and 80%, that is equivalent to multiply by 1,43 and 1,25 respectively the number of grains needed.

Find as follows a method to determine the kgs per hectare to sow starting from plants per square meter we want obtain.

1) Introduce «grain counter» in the seed bag. Then, verify that in each hole we have only one seed (100 grains in total)
Repeat the operation 10 times (you will obtain 1000 grains)
If the machine is type TRI-294/R-ESP , the operation will be manual.

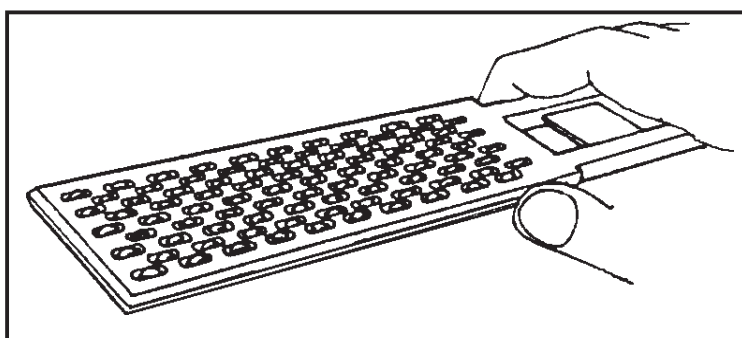

fig. 4

2) To weight the 1000 grains in the precision weighing machine. The weight will be the OPERATIVE WEIGHT.

3) When we know the grains per square meter to sow, the kgs per hectare to adjust in the dosage control are:

$$\text{kgs per hectare} = (\text{grains per m}^2 \times \text{OPERATIVE WEIGHT}) / 100$$

5. STARTING OPERATION

5.1 COUPLING

The machines are equipped with a quick coupling device to the tractor hydraulic lifter. The pulling bar allows the machine adjustment to terrain unevenness. For uncoupling, with the machine lifted, open both blocks (1, fig. 5), and fix (2, fig. 5) from lever (3, fig. 5) to axle of Ø16 mm (4, fig. 5).

When the tractor arms are too short, it is necessary to place the AUTOMATIC COUPLING, that place on the same time the three points of the elevator and hold up 12 cm the machine from the tractor.

All the machines are fitted with a support for transport securement. Do not forget to dismantle this support before working.

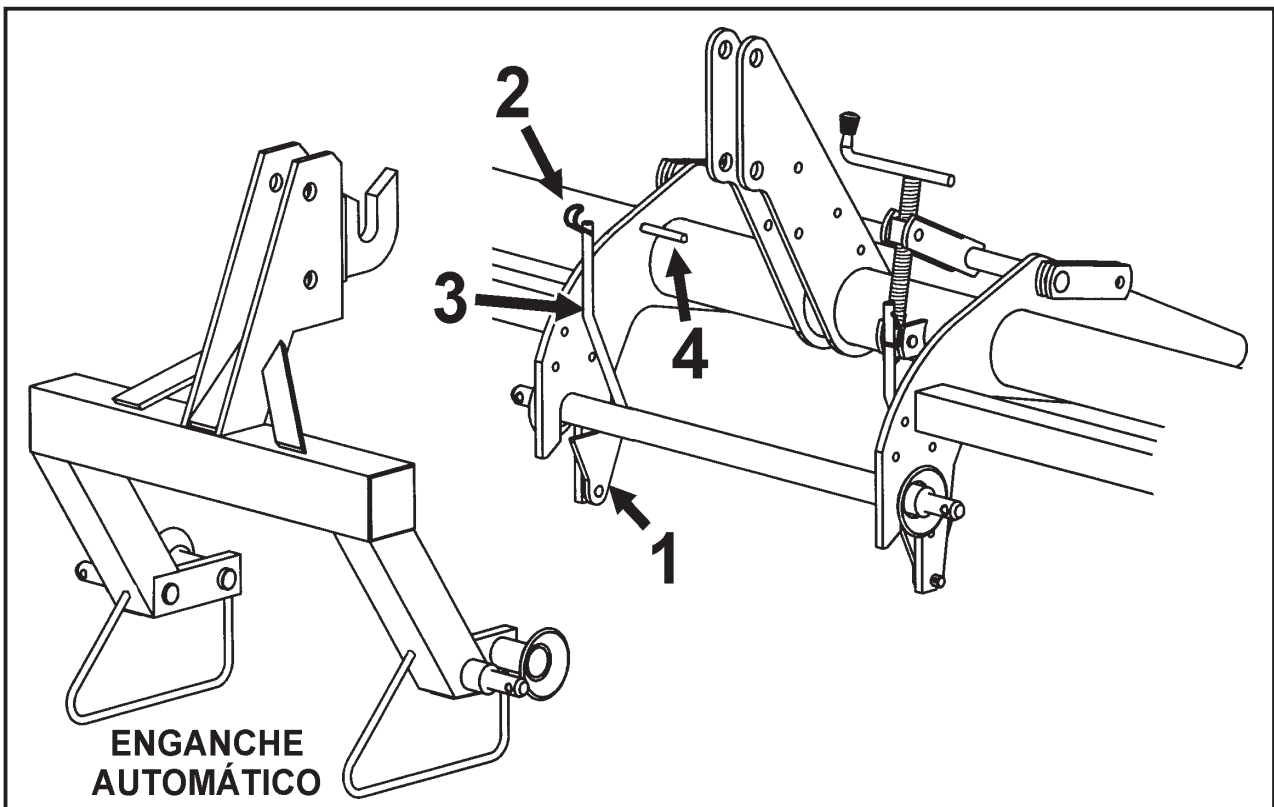

fig. 5



Verify that nobody is between the seed drill and the tractor during coupling operations.

5.2 DISPENSER MECHANISM

Solà dispenser roller can be adjusted with two working positions:

- Narrow cog with small teeth for small seed (fig. 6).
- Wide cog with large alternated teeth for normal and big seed (figs. 7 and 8).

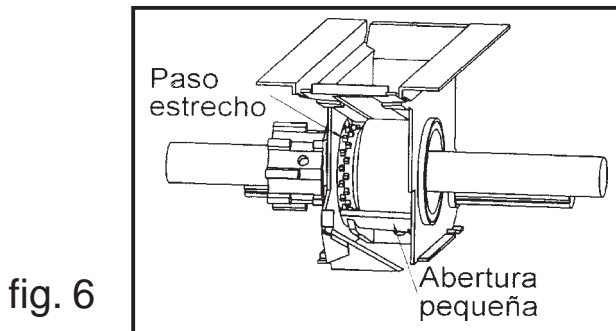

fig. 6

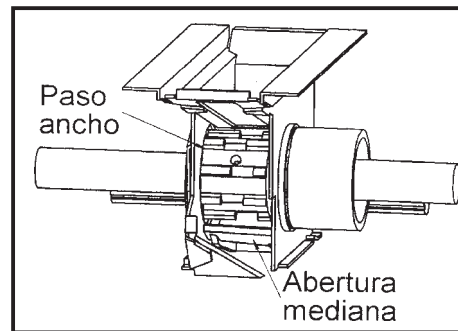

fig. 7

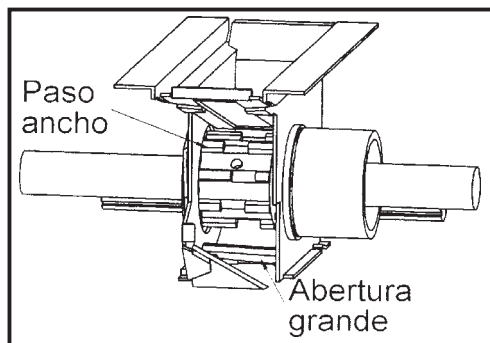

fig. 8

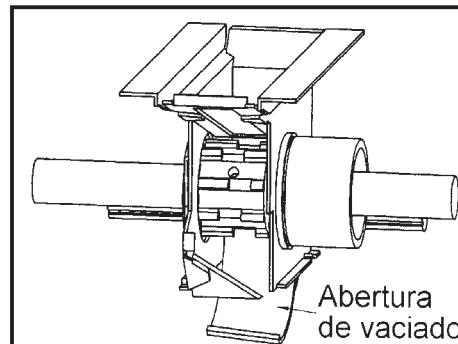

fig. 9

The seed mobile bottom has two objectives:

- To adjust the lower seed dispenser opening according to the grain size (figs. 6, 7 and 8).
- Open the distributor system to empty the hopper (fig. 9).

When shifting the seed dispenser roller between **NARROW** and **WIDE** positions, make sure the roller is empty.



Once the seed dispenser roller position (wide or narrow) is decided and the mobile bottom adjusted, the seed flow depends only on the rollers turning speed.

The seed speed variator accomplishes this mission, by allowing to deliver from 0 to 600 kg/ha, with rigorous precision.

5.3 SEED DOSAGE

Verify that the seed dispenser trapdoors are opened and allow the seed flow. **Before filling the hopper, attach the agitator to the seed speed variator axle.**

Make sure that there are no strange bodies in the hopper.

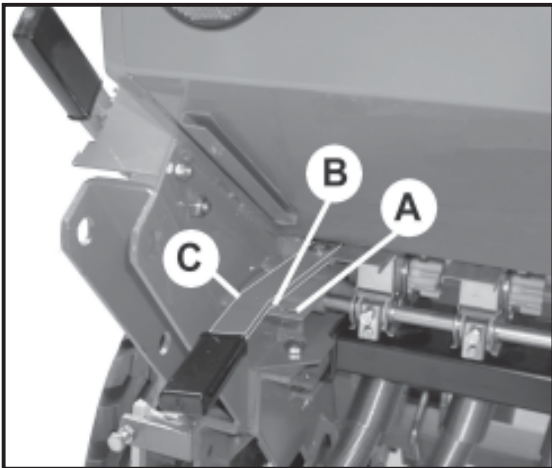

Place the position lever of the dispensers:

- A. right, wide cog for wheat, barley, etc. (fig. 10)
- B. centre, medium cog for sunflower, peas, etc. (fig. 10)
- C. left, narrow cog for lucerne, rape, etc. (fig. 10)

Place the mobile bottom lever (on the left side of the hopper) on the sector of 7 positions:

- Nº 1, for small seed (fig. 11)
- Nº 3, for wheat and barley (fig. 11)
- Nº 5, for big seed

To empty the hopper, place the plate under dispensers and take the lever to the front further on number 7. (fig. 11)

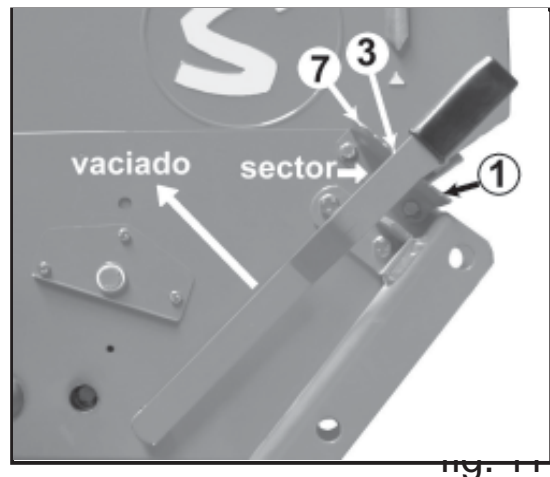

Finally, select the seed speed variator, place the lever on the sector from 0 to 100 and fix again on the number selected (fig.12). See the tables (pgs. 38-41).

fig. 12

5.4 SEED CONTROL

Once the dispensers position is correct, the mobile bottom opening and the variator lever, it is very important and necessary to test the seed dose.

FIRST: slide the distribution bar (1, fig. 13) along its rails by releasing the clamps (2, fig. 13) just in the correct position in order to place the plate.

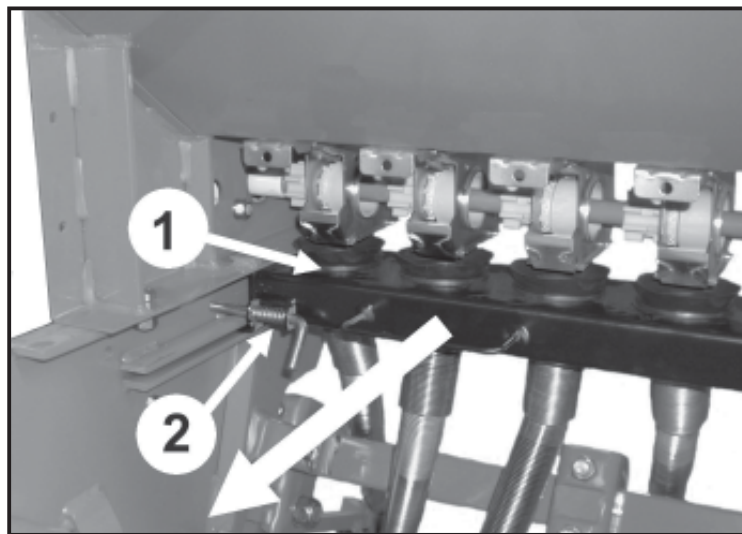

fig. 13

SECOND: slide the plate (3, fig. 14) from the transport position (4, fig. 14) under the dispensers.

Machine TRI-294/R-ESP does not fitted with the plate. In this case you must use a plastic film under the dispensers to collect the seed.

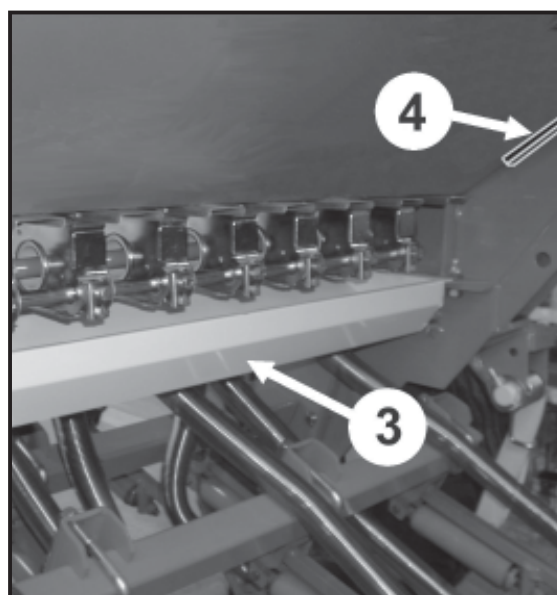

fig. 14

THIRD: place the shaft lever (1, fig. 15) in its place (2, fig. 15) on the right wheel and give some clockwise turns to the driving wheels, until some seed is delivered. Collect up the seed and return it to the hopper. The machine is ready for the real test. If your machine is TRI-294/R-ESP type, you will have to turn manually.

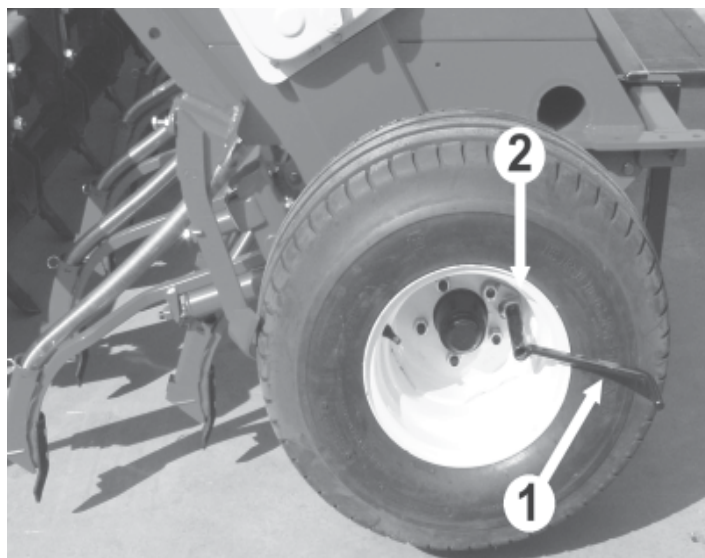

fig. 15

| type | wh 6.00-16 | wh 10.80-12 |
|------|------------|-------------|
| 250 | 44 turns | 46 turns |
| 300 | 36,5 turns | 38 turns |
| 350 | 31,5 turns | 33 turns |
| 400 | 27,5 turns | 29 turns |

Give the turns indicated in the table above, approximately on turn per second. The number of turns may vary depending on the soil conditions, the wheel manufacturer or the tyre pressure. It is very important to do a land test as you have in the 5.5 part of this booklet.

After, collect and weight up the delivered seed in the plate or in the plastic film. Multiplying the result by 40 we obtain the kgs per hectare that the machine will distribute.

To realise these operations, it is very important that the machine is coupled to the tractor and slightly lifted (the wheels must turn freely), and it is also recommended to fill only half-hopper in order to make possible the wheel turning.

If the seed has an excess of preservation powder it may result in a flow decrease. So, it is recommendable to do a second dose test after having sow three or four hoppers.



Be careful with the wheel.
You could damage with the wheel scraper.

5.5 LAND TEST

If it seems that there are significant differences between the dose test and the actual dispensed dose, due to an irregular or soft terrain, a field test can be performed.

First, with a measuring tape, signpost the test distance in meters in the plot of land that is to be sown.

| Machine type | Distance (m) |
|--------------|--------------|
| 250 | 100,0 |
| 300 | 83,3 |
| 350 | 71,4 |
| 400 | 62,5 |

Second, with the seed drill in working position, cover that distance. Count the wheel turns needed to complete the path. Put a mark on the tyre to make this easier.

With theses operations we will obtain the turns number for the seed test. If we do the test with this turn number, we are going to obtain the kgs per hectare delivered by the seed drill.

5.6 COMBINED DISTRIBUTION

Combined dispensers are one part by stainless steel and another part in Delrin.

Seed distribution roller is the same than the seed drill dispenser (see 5.2) and the fertilizer dispenser has constant step, fitted on hexagonal axle, to make easy to dismantle, without tools.

The fertilizer mobile bottom its a detachable stainless steel cover, this allows fertilizer roller cleaning (fig. 16).

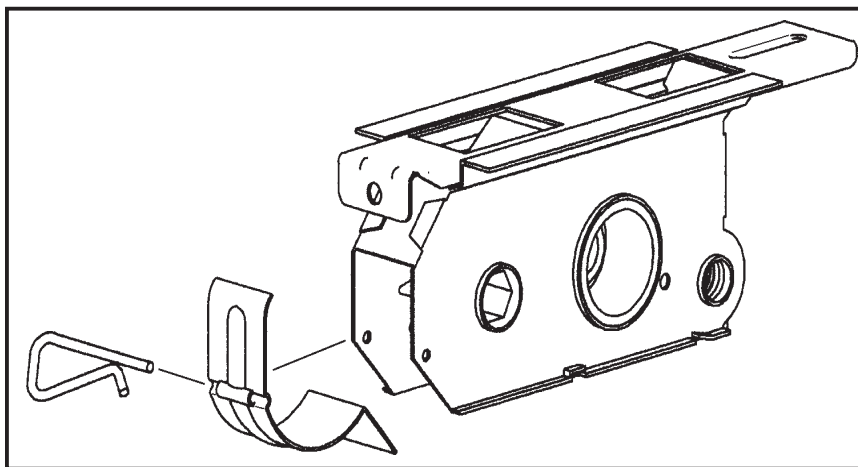

fig. 16

5.7 COMBINED HOPPERS

Combined hopper has two compartments: back compartment for seed (1, fig. 17) and the front compartment for fertilizer (2, fig. 17). The fertilizer compartment has a mesh cover (3, fig. 17) in order to avoid strange bodies, like stones, damaging the dosage mechanism.

Each compartment is fitted with its own flow control device.

The fertilizer compartment has a folding device (4, fig. 17) to avoid the fertilizer overflowing between the hopper and the cover. This folding device is not fitted with the machine TRI-294/R-ESP

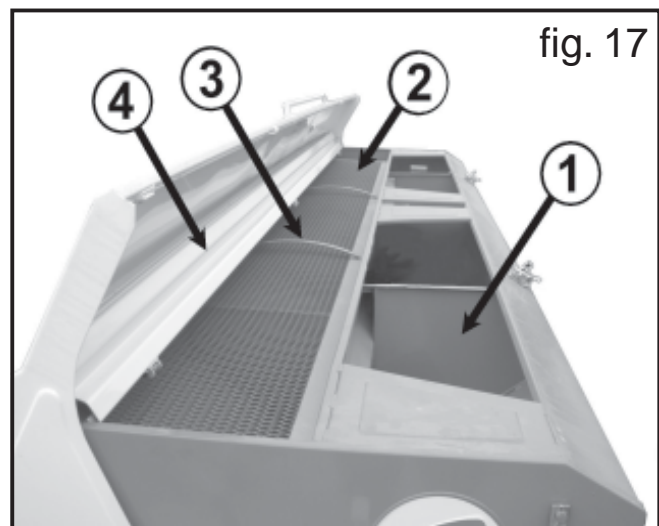

fig. 17

5.8 COMBINED DOSAGE

On the combined machines, dosage and seed control is the same to the seed drills.

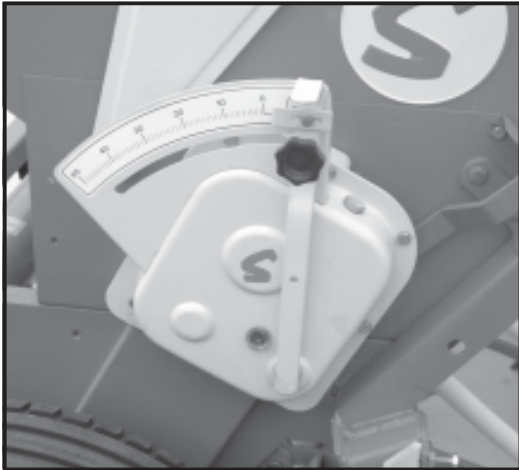
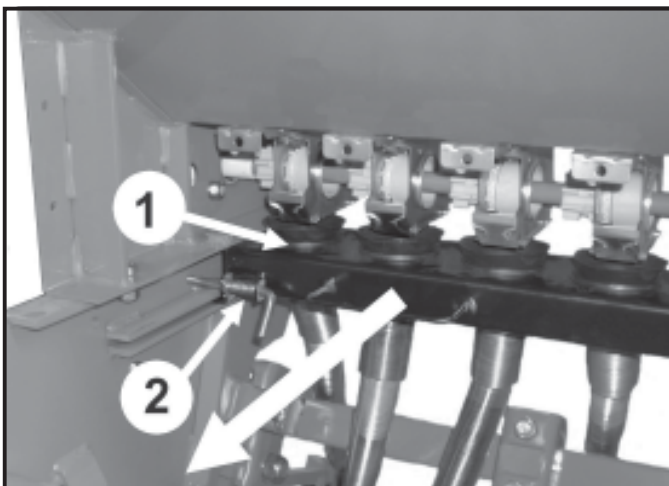

fig. 18 (page 42).

The fertilizer dosage has to be done by means of the fertilizer variator placed on the left side of the machine (fig. 18), positioning the lever on the graded scale from 0 to 50 and fixing it on the number selected in the dosage tables.

These tables are for guidance only. The fertilizer density can vary depending on manufacture process.

So, we recommend to carry out a fertilizer dose test likewise that of the seed:



FIRST: slide the distribution bar (1, fig. 19) along its rails releasing the clamps (2, fig. 19), in the working position in order to place the plate.

fig. 19

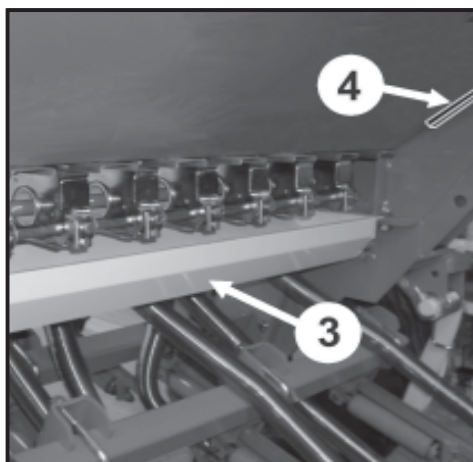
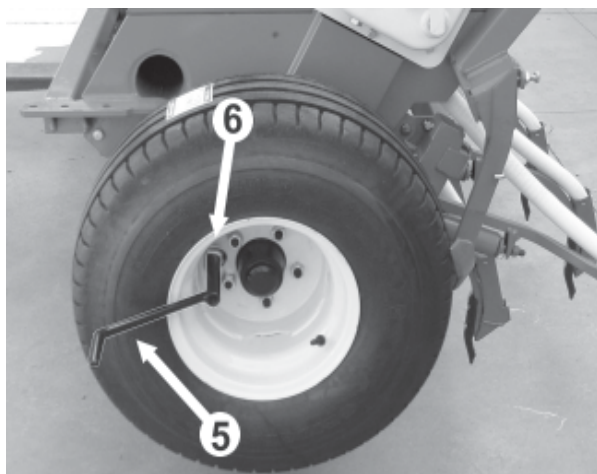

fig. 20

SECOND: slide the plate (3, fig. 20) from the transport position (4, fig. 20) and place it under the dispensers.

Machine TRI-294/R-ESP does not fitted with the plate. In this case, use a plastic film to collect the seed.



THIRD: place the lever (5, fig. 21) in its place (6, fig. 21) on the left wheels and give some clockwise turns to the driving wheel, until some seed is delivered. The machine TRI-294/R-ESP does not fitted with the lever, you will have to turn manually. Collect up the fertilizer and return it to the hopper and and give the turns as follows:

fig. 21

| type | wheels 6.00-16 | wheels 10.80-12 |
|------|-------------------|--------------------|
| 250 | 44 turns | 45 turns |
| 300 | 36,5 turns | 37,5 turns |
| 350 | 31,5 turns | 33 turns |
| 400 | 27,5 turns | 29 turns |

The fertilizer collected, multiplied by 40, are the fertilizer kgs per hectare that the machine will distribute with the lever in the sector choosed. It is very important to do a precision test with the fertilizer, to verify the fiability level of the table.

(pag. 42).



Beware of getting injuries from the scraper when turning the wheel



Optionally, combined machines can be delivered with one or two seed and fertilizer tubes

In the double tube option and with wet weather, it is **VERY IMPORTANT** to clean de fertilizer compartment of the nozzle, in order to avoid the blockage danger.

It is important to clean with plenty of water nozzles, pipes and coulter for preventing rust.

5.9 ARMS ADJUSTMENT

5.9.1 TRI 294/R - Height and depth

We can adjust each arm, working (A, fig. 22) on two bolts.

On wet and soft lands, the mark of the tractor wheel waits on the soil. It is very important to adjust with more pressure in the coulters that coincide with the wheels and to elevate the coulters of the centre. With track breakers arms is not necessary to adjust it.

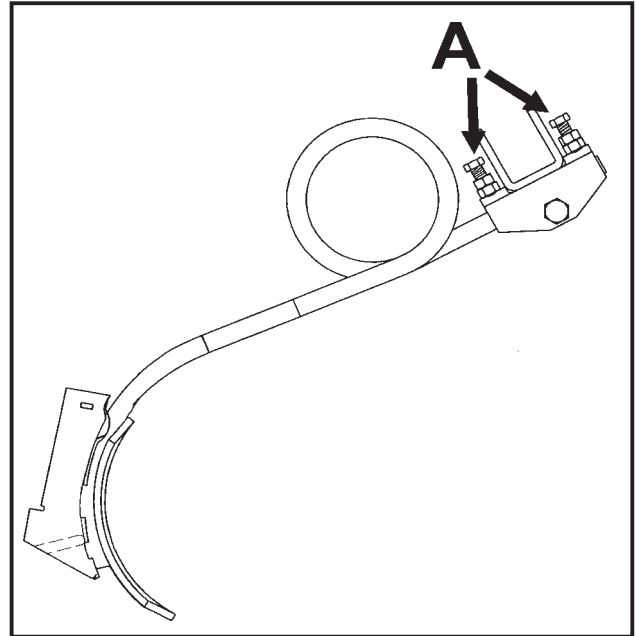

fig. 22

5.9.2 TRI 194/R - Constant adjustment

To adjust the arm fixing to the support by a special bolt SOLÀ (1, fig. 23) fitted with auto-blocking bolt.

Working on this bolt we can control the lateral position. The arms will be always in good position. pre perfectamente ajustados. Para To adjust the coulters pressure, we must work on the coulters strut (2, fig. 23).

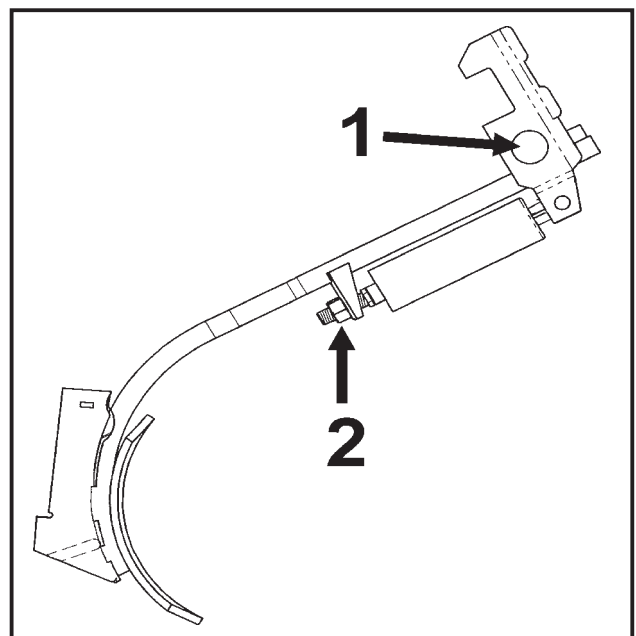

fig. 23

5.10 LEVELING AND DEPTH CONTROL

We can adjust the arms depth by a central bolt (1, fig. 24). Before, we inform you about the way to adjust the arms.

The machine has to work with the hopper in a flat position. The oscillating arrow has to coincide with the mark (2, fig. 24). We can adjust the position with the tractor hydraulic elevator.

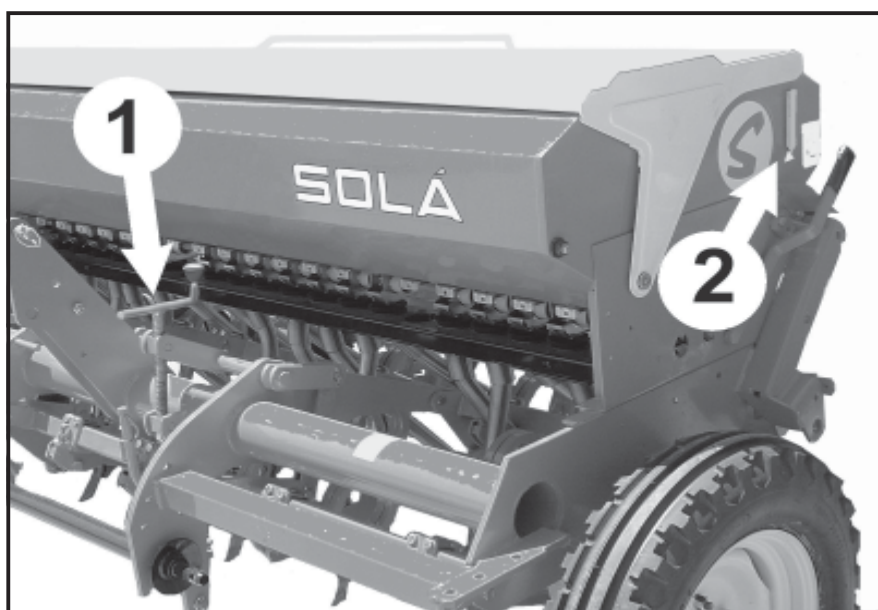

fig. 24

5.11 WHEEL SCRAPERS

We can adjust the scrapers by a bolt placed in the superior part of the arm (does not fitted in type ESP).

Some times, when the machine is lifted to the tractor, the wheels are turning because of its fitting with bearings, and the seed goes on falling.

To avoid this, we can adjust the scraper bolt in such a way that touch lightly the wheel. This small brake is enough to avoid the wheels turning.

BLOCKING: in wet and clayey land it can be interesting to block the scrapers, blocking the spring joint.

We can place a bolt in the borer coincidence of the scrapers and its support.

6. OPTIONAL EQUIPMENT

6.1 TRACK ERASERS

Track erasers are the best and effective option to erase the tractor tracks. We can adjust the four arms in height and length depending of vehicle width.

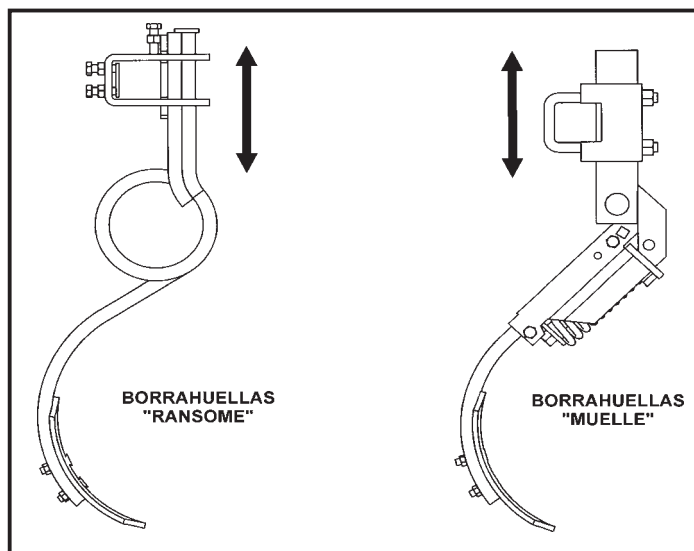

fig. 25

6.2 LEVELER

The leveler adjusts the land roughness.

The regularity in the land makes easy the seed deposition to the correct depth. With two springs (A, fig. 26) we can adjust the pressure.

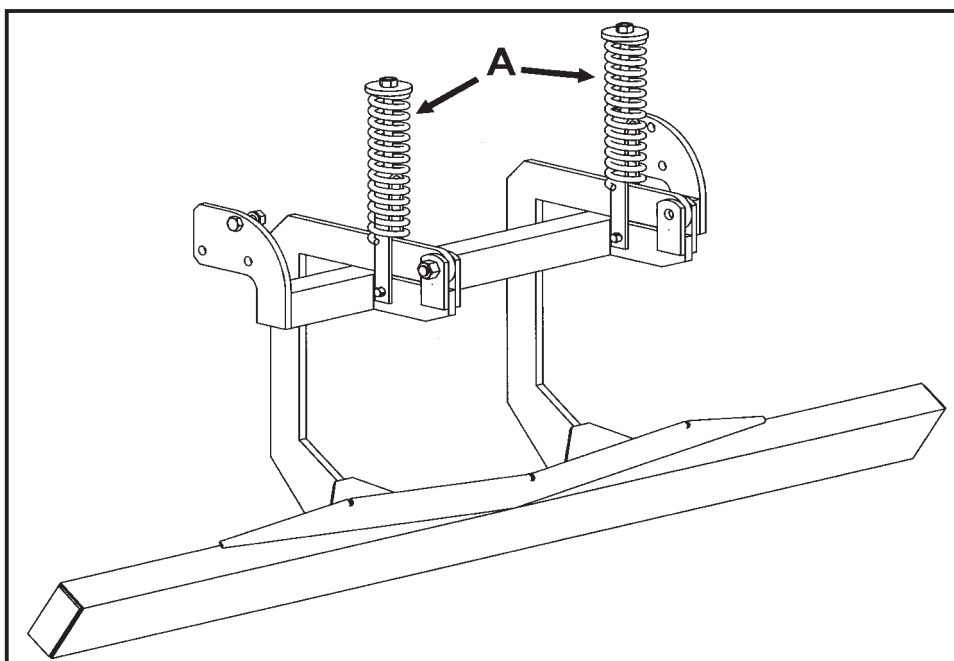

fig. 26

6.3 HARROW WITH FLEXIBLE TINES. TYPE EPI-6 AND EPI-7

The seed drill TRI is supplied with a parallelogramic spring harrow. The springs are double-toothed(3, fig.27) in order to cover the furrow with the taken out soil.

Adjusting the upper bolts of both arms, the working pressure is (1, fig. 27) increased or decreased. Adjusting the lower bolts (2, fig.27) , modifies working depth.

The parallelogramic articulation achieves an excellent adaptation of the double-toothed springs to the terrain unevenness, vertically and horizontally.

Always you must order original SOLA tines, they have had a strict quality control.

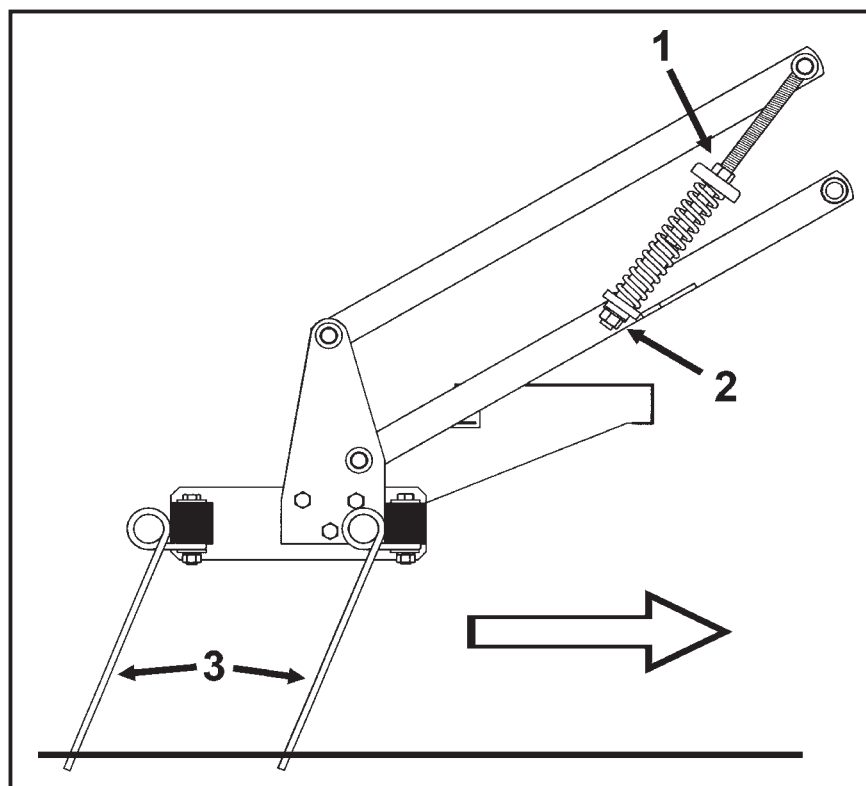

fig. 27



It is forbidden to ride on the harrow when the machine is working.

6.4 SPRING HARROW. «E» TYPE

The seed drill TRI-294/R-ESP can be delivered with flexible tines harrow. Double tines springs (3, fig. 28) help to cover the furrow with the taken out soil.

Adjusting the upper bolts of the arms, the working pressure is (1, fig. 28) increased or decreased. Adjusting the lower bolts (2, fig. 28), we can modify the working depth.

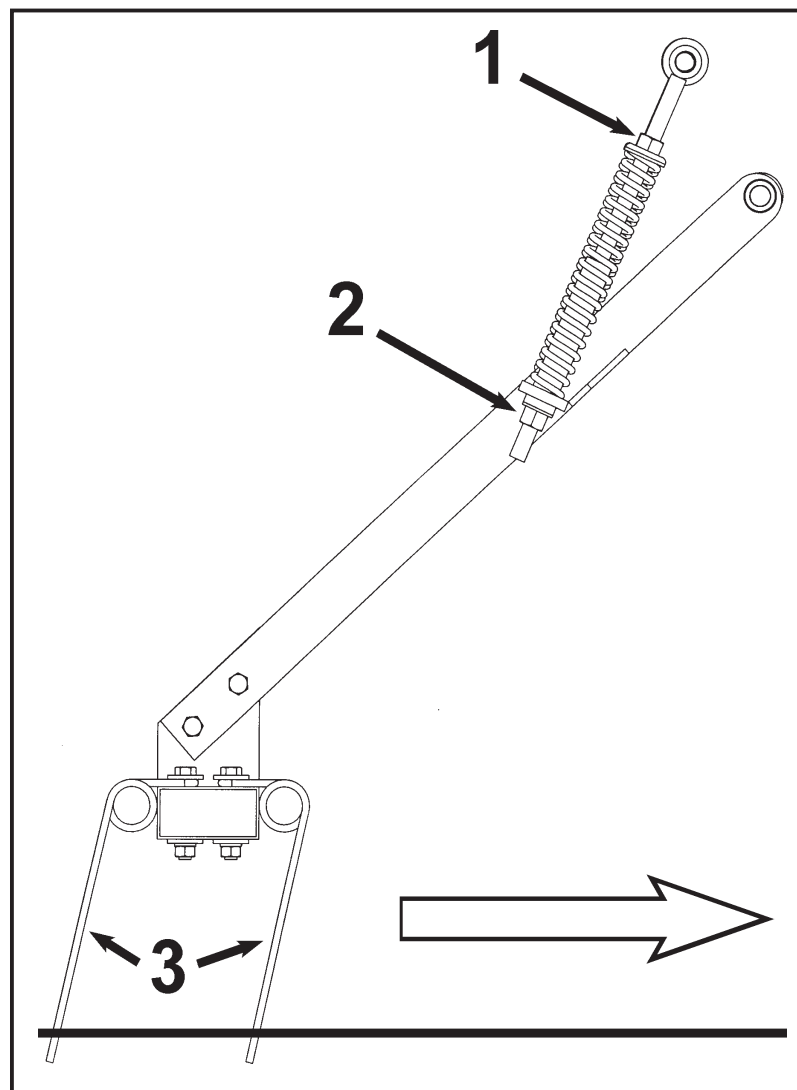

fig. 28



It is forbidden to ride on the harrow while sowing.

6.5 DISC MARKERS

6.5.1 Hydraulic disc markers

Place the markers by three bolts on the platen placed in the machine lateral.

The working cylinder must be connect to a double effect device in order to control the arms position. When one arm is in vertical position, the other is in working position.

The cylinders have a throttle inside in order to slow down the track markers lift.

Verify, before to working, that the track marker goes fine.

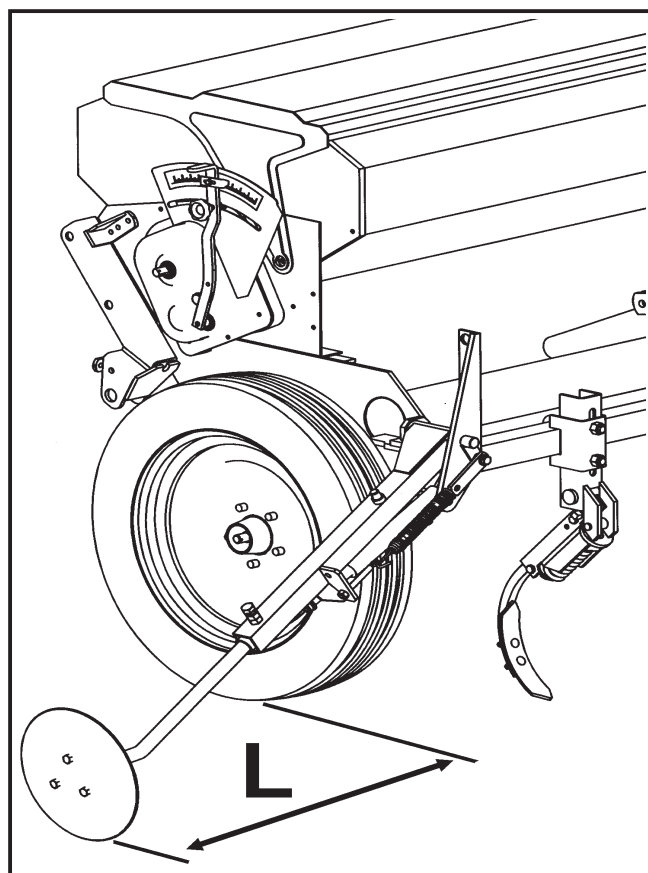

fig. 29

Track markers arms are extensible in order to adjust them and the disc can be adjusted in order to obtain the correct position.

For the hydraulic action, we can obtain a supplementary springs in order to adjust the disc pressure on the land.

To calculate the distance between the disc and the wheel exterior part (L, fig. 29) we can apply the following formula:

$$L = \text{seed drill working width} - \frac{\text{front line tractor width} + \text{machine total width}}{2}$$



Pressure oil can be penetrate in the skin. Danger of serious damages. Keep the tubes, pipes, in good conditions.



Never place in the folding race of the markers

To circulate with the machine by the road, it is very important circulate with the markers in vertical position, fixed with the clamp to avoid their descent during the transport (fig. 30).

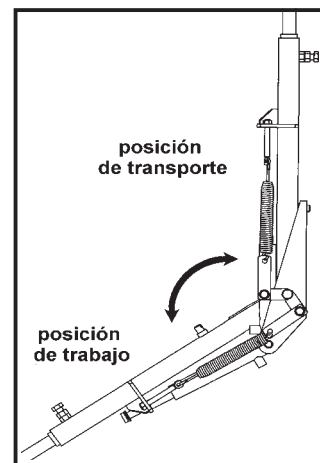

fig. 30



Pay attention with hydraulic tubes.

:

:



It is not convenient to exceed with the spring pressure and verify the disc position to avoid damages.

6.5.2 Mechanical disc markers

Mechanical disk markers are assembled on both sides of the machine. Its operation is by cables (A and B, fig. 31), by a central control (C, fig. 31), fitted to the machine tripod. (D, fig. 31).

Track markers activation is alternative changing the position of the control lever (C, fig. 31).

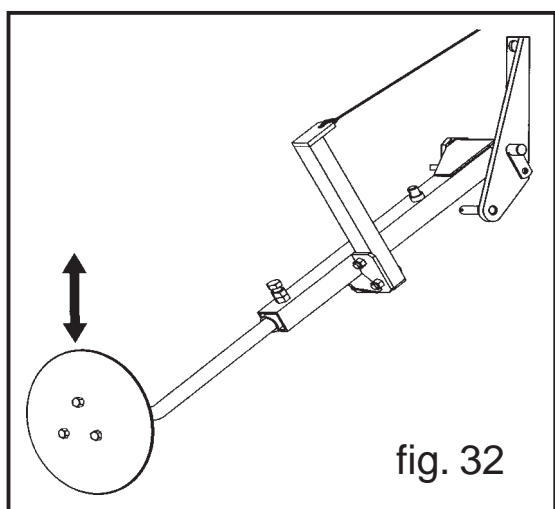

fig. 32

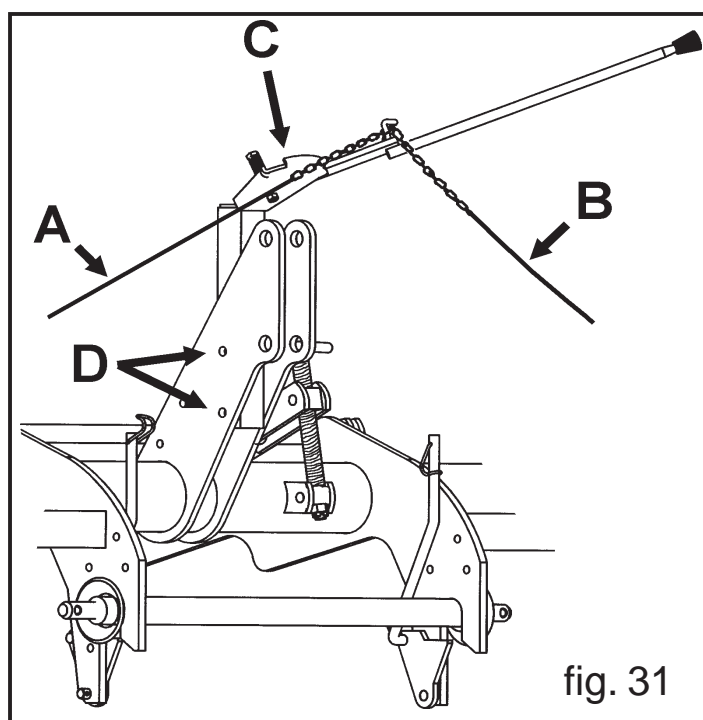

fig. 31

6.6 HECTARE COUNTER

The hectare counter is placed on the right side of the machine under the seed speed variator. It must be fitted in the (A, fig. 33) shaft that juts out the seed speed variator and screwed in the M-8 thread hole.

A special non-trapping screw (B, fig. 33) is supplied together with the hectare counter.

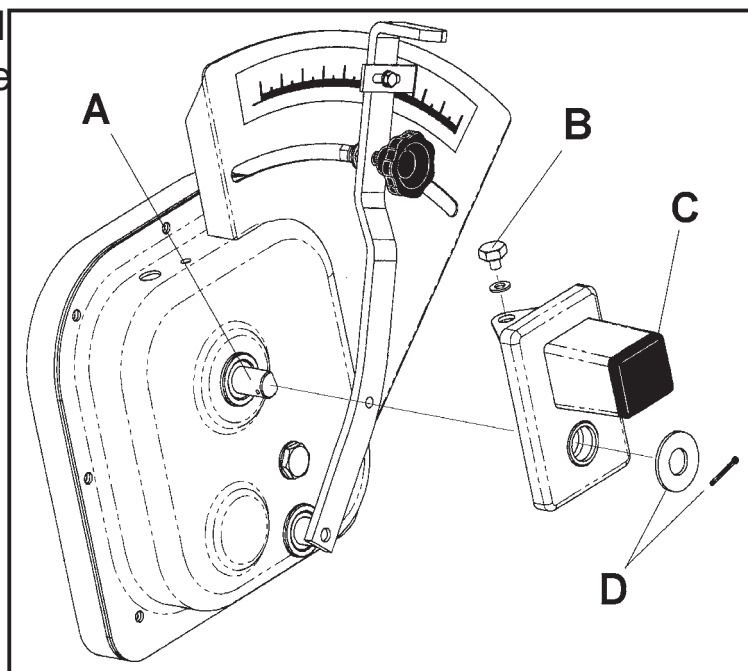

fig. 33

Removing the black lid (C, fig. 33) from the transparent box, the initializing command will be accessible.

Finally, fit a washer and its pin at the end of the variator shaft (D, fig. 33). Make sure that the pin doesn't brush against the hectare counter box.

Hectare counter «SOLÀ 90» has direct scanning (in both hectare and square meters). Transmission gears are specific for each machine, as follows:

| Machine | Motor pinion | Driven pinion |
|---------|--------------|---------------|
| 250 | Z-28 | Z-65 |
| 300 | Z-32 | Z-61 |
| 350 | Z-34 | Z-59 |
| 400 | Z-37 | Z-56 |



If the hectare counter is not supplied with the machine it is very important to verify if the gears are correct.

6.7 CULTIVATOR

The cultivator is an optional equipment for the soil preparation before sowing. It is fitted between the tractor and the seed drill. The joint with the first is an coupling bar (1, fig. 34) and with the second by two coping arms (2, fig. 34) and a strut (3).

fig 34) that links the two coupling points of the tripods of the machine and the cultivator.

The cultivator working must be superficial, excepting for the arms placed on track marks that must be adjusted to erase the track markers. Each arm can be adjusted in horizontal and vertical way.

The cultivator can be adjusted for four different working depth, limiting the coupling arms with a bolt (4, fig. 34).

The cultivator has a lateral movement and the height is independent on the seed drill. It is possible to elevate it while the seed drill rests on the soil.

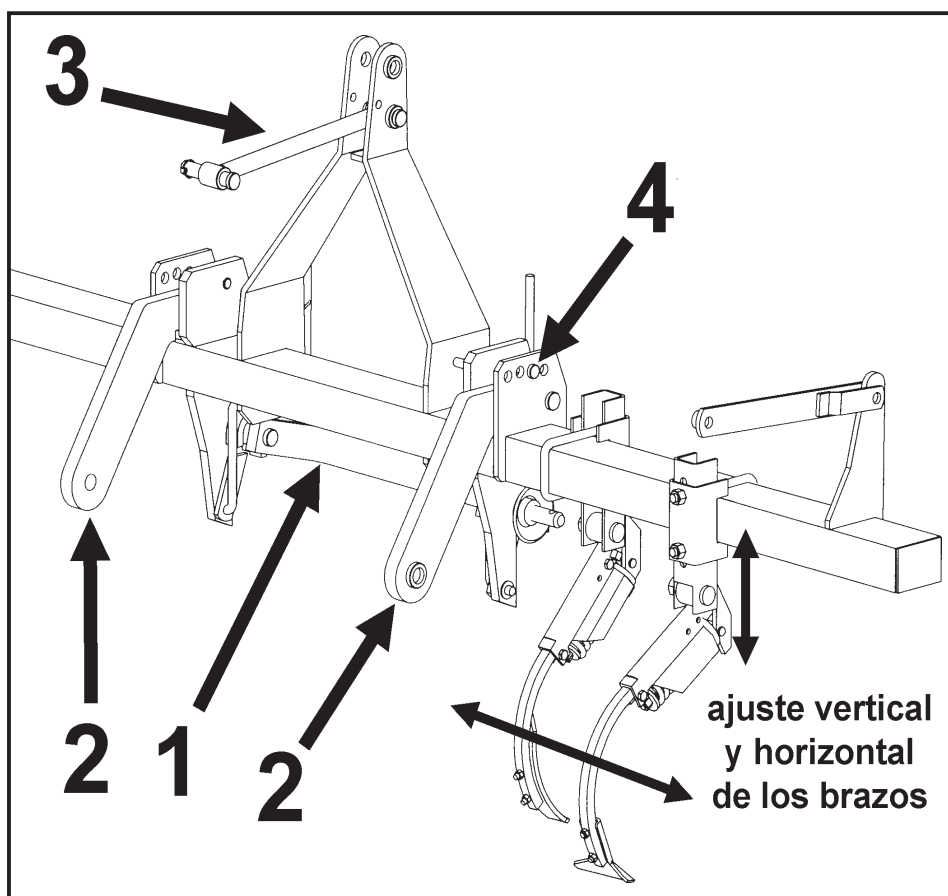

fig. 34

6.8 VARIATOR HYDRAULIC CONTROL

Both variators can be fitted with hydraulic controls for the distance work.

The control is fitted with a simple effect hydraulic cylinder with return spring, that works the variator lever on the positions

«closed» (circuit with pressure) and «sowing» (circuit without pressure). This one is the seed or fertilizer dose that we have selected placing a stop (5, fig.35) in the scale.

The cylinder (1, fig. 35) is fitted in the variator lever (2, fig. 35) by a bolt (3, fig. 35) and in the side of the machine with a support (4, fig. 35). The cylinder goes with a small belt to connect to a tractor pressure exit of 1/2”.

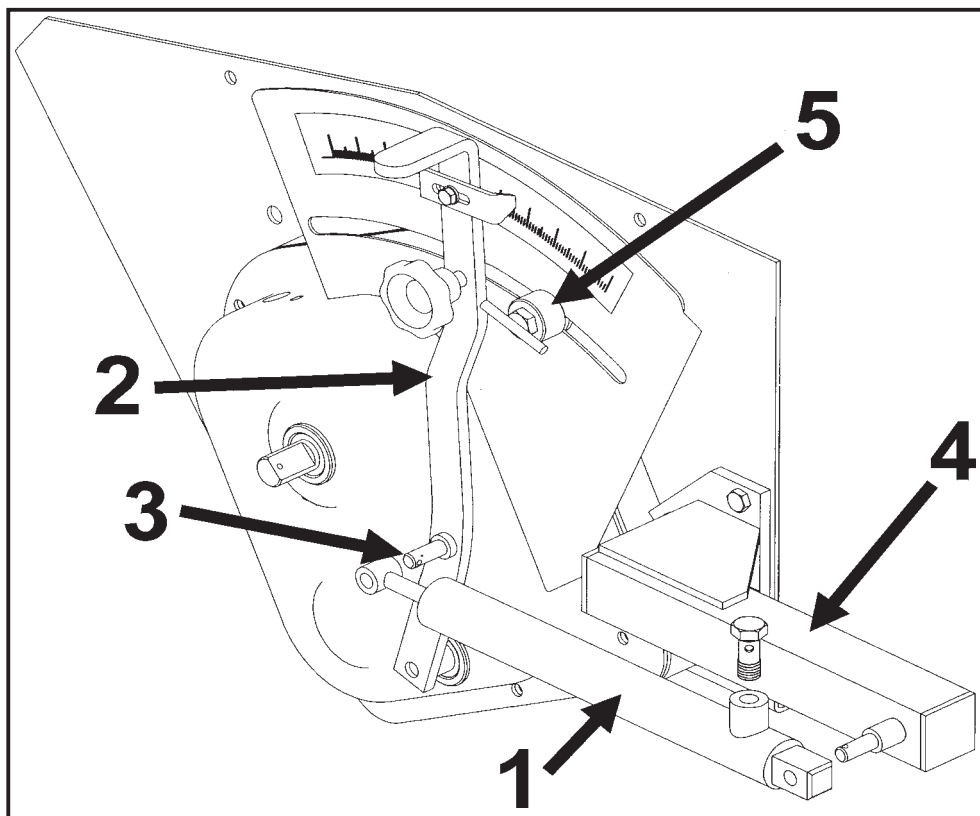

Pressure oil can penetrate in the skin and to cause dangerous damages. Pay attention with tubes and pipes.



7. MAINTENANCE

7.1 GREASING

Grease regularly the following parts:

Wheel axles, removing the pressure tap.

Calcic dense grease (1, fig 36)

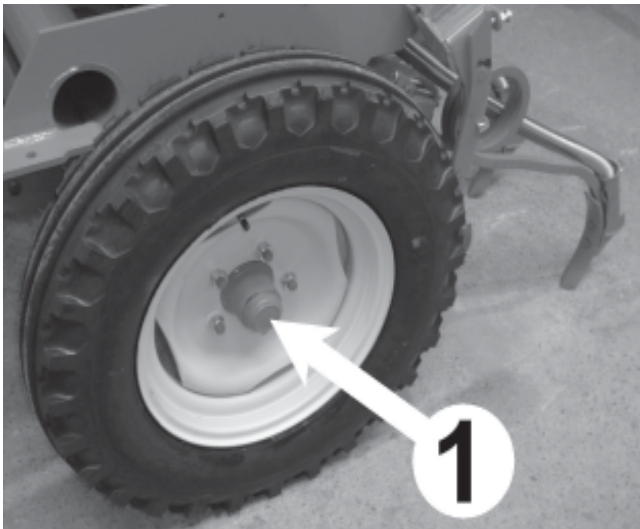

fig. 36

Wide-narrow switching roller.
Calcic dense grease.
(2, fig. 37)

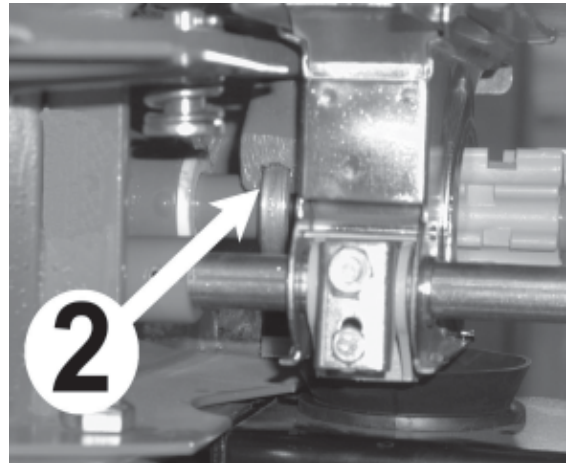

fig. 37

Arms
pressure
central
spindle.
Calcic
dense
grease
(3,
fig. 38)

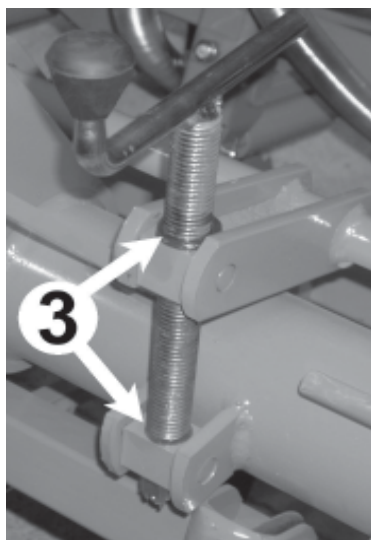
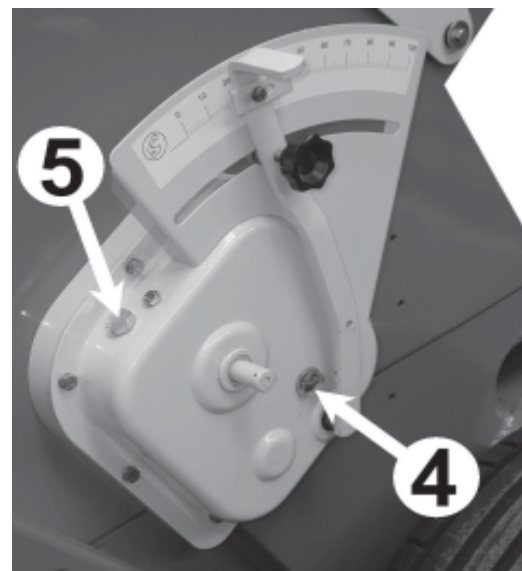

fig. 38

fig. 39



Verify variator oil level
through the spyhole (4,
fig. 39) and if necessary
remove the plug and refill
with SAE 30 oil (5, fig. 39)



Do not grease
the dispensers.

7.2 TYRE PRESSURE

The following data is corresponding with the full-load pressure prescribed by the tyre manufacturer.

| | | |
|----------------|-----|-------------------------|
| Tyre 6.00 -16 | --- | 3,75 kg/cm ² |
| Tyre 10.80 -12 | --- | 3,75 kg/cm ² |

Generally, in poor prepared soils, we recommend to reduce a bit the pressure in order to overcome the terrain irregularities and achieve more sowing regularity.

7.3 NUTS AND BOLTS

After some working hours, all bolts must be inspected and tightened if necessary, specially those tying the coulters.

For these bolts, a special tube key (1, fig. 40), is supplied with the machine.

fig. 40

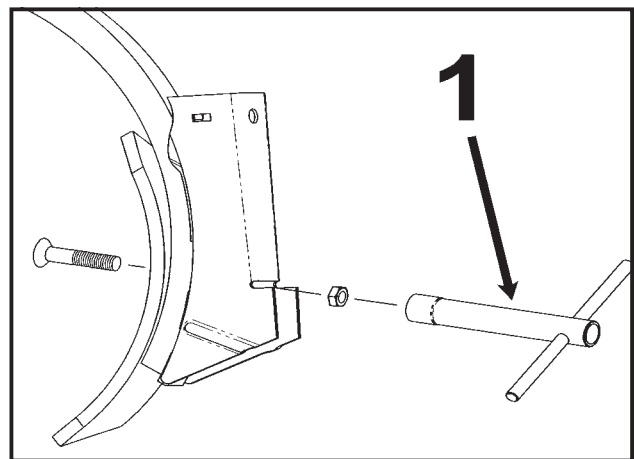

7.4 ANTIOXIDE CONTROL (COMBINED MACHINE)

Once the sowing season is finished, antioxide maintenance must be carried out as follows:

- a) Dismantle the pipes, the nozzles and dispenser stainless-steel covers. Clean them thoroughly.
- b) Wash with water jet the whole machine, specially inside the hopper and the dispensers (with the covers removed). Turn the left wheel so that the fertilizer rollers can be completely washed.
- c) Give a coat of paint to those parts with oxidation signs, specially those made of metal sheet.
- d) Verify the general greasing.

7.5 PROBLEMS SOLUTION

Sometimes and working with the machine, you can have some problems. Find as follows the problems more usual problems.

.

Problems with distribution system:

- Verify there are not strange elements into the distributors.
- Verify the distributors exit trap-doors. Trap-doors must be totally open.
- Verify the trap-doors are in the correct position.
- Verify the distribution rollers.
They can be damaged.
- Avoid to work in very closed circles: it could produce a bad seed distribution.

The dose is not correct (it is inferior).

- Please, follow the booklet instructions to adjust the dose. Pay attention with the pressure wheels, wheel sliding on the land, etc.
- If the driving wheel do not touch the soil, verify the tractor hydraulic arms are well adjusted.
- Verify the connection fastener between the variator and the distributor axle.
- Wheel scrapers can brake the drive wheel.
- Verify the transmission device: bushing tooth, chain and variator pinion.
- After doing all the checking and the problem exists, please ask your SOLÀ dealer. Do not try to repair the variator.

8. DOSAGE TABLES



The quantities you have found in the tables are for guidance only. The flow can vary due to preservation powder, seed size, density and humidity.



To do a precision sowing, please follow the process described in sections 5.4 and 5.5 you can find in this manual.



As a general rule, small grain needs less opening than the big, round grain needs less opening than length and light grain needs more opening than the heavy.

8.1 SEED DOSAGE TABLE (kg/ha)

| Adjust. lever \ arms dis. (cm) | WHEAT | | BARLEY | | TRITICALE | | PEAS | | BEANS | |
|--------------------------------------|-------|------|--------|------|-----------|------|-------|-----|-------|------|
| | 12 | 13,5 | 12 | 13,5 | 12 | 13,5 | 24 | 27 | 12 | 13,5 |
| 14 | | | | | | | | | 81 | 71 |
| 16 | | | | | | | | | 97 | 85 |
| 18 | | | | | | | | | 115 | 101 |
| 20 | 89 | 78 | 69 | 61 | 67 | 59 | 46 | 40 | 136 | 120 |
| 22 | 100 | 88 | 77 | 68 | 74 | 65 | 51 | 45 | 152 | 134 |
| 24 | 111 | 98 | 85 | 75 | 82 | 72 | 55 | 48 | 168 | 148 |
| 26 | 120 | 106 | 95 | 84 | 89 | 78 | 61 | 54 | 192 | 169 |
| 28 | 132 | 116 | 103 | 91 | 98 | 86 | 67 | 59 | 210 | 185 |
| 30 | 140 | 123 | 113 | 99 | 106 | 93 | 74 | 65 | 228 | 201 |
| 32 | 147 | 138 | 120 | 106 | 116 | 102 | 77 | 68 | 248 | 218 |
| 34 | 158 | 143 | 130 | 115 | 127 | 112 | 82 | 72 | 265 | 233 |
| 36 | 168 | 148 | 140 | 123 | 139 | 122 | 88 | 77 | 288 | 253 |
| 38 | 177 | 156 | 148 | 130 | 148 | 130 | 92 | 81 | | |
| 40 | 188 | 165 | 157 | 138 | 157 | 138 | 97 | 85 | | |
| 45 | 210 | 185 | 177 | 156 | 173 | 152 | 101 | 89 | | |
| 50 | 232 | 204 | 195 | 172 | 189 | 166 | 110 | 97 | | |
| 55 | 255 | 225 | 224 | 197 | 208 | 183 | 115 | 101 | | |
| 60 | 277 | 244 | 235 | 207 | 226 | 199 | 124 | 109 | | |
| 65 | 300 | 264 | 255 | 224 | 244 | 215 | 152 | 134 | | |
| 70 | 324 | 285 | 273 | 240 | 263 | 231 | 165 | 145 | | |
| 75 | 347 | 305 | 293 | 258 | 281 | 247 | 176 | 155 | | |
| 80 | 370 | 326 | 310 | 273 | 299 | 263 | | | | |
| 85 | 390 | 343 | 330 | 290 | 316 | 278 | | | | |
| 90 | 411 | 362 | 347 | 305 | 335 | 295 | | | | |
| 95 | 433 | 381 | 366 | 322 | 353 | 311 | | | | |
| 100 | 457 | 402 | 384 | 338 | 373 | 328 | | | | |
| dispenser position | WIDE | | WIDE | | WIDE | | WIDE | | WIDE | |
| Mobile bottom lever position | 3 | | 3 | | 3 | | 4 | | 5 | |
| 1000 grains operative weight | 40 g | | 46 g | | 30 g | | 293 g | | 530 g | |

TRI-194/R AND TRI-294/R Wheels 6.00-16

| RAPE | | SAINFOIN | | VESCE | | RAY-GRAS | | LUCERNE | | SPINACH | |
|--------|------|----------|------|-------|------|----------|------|---------|------|---------|------|
| 24 | 27 | 12 | 13,5 | 12 | 13,5 | 12 | 13,5 | 12 | 13,5 | 12 | 13,5 |
| 4.0 | 3.5 | 24 | 21 | 76 | 67 | | | 13.6 | 12.0 | 5.9 | 5.2 |
| 5.3 | 4.7 | 30 | 26 | 92 | 81 | | | 16.6 | 14.6 | 7.0 | 6.2 |
| 6.0 | 5.3 | 35 | 31 | 111 | 98 | | | 20.1 | 17.7 | 8.8 | 7.7 |
| 7.0 | 6.2 | 40 | 35 | 128 | 113 | | | 22.7 | 20.0 | 10.5 | 9.2 |
| 8.5 | 7.5 | 44 | 39 | 148 | 130 | | | 26.0 | 22.9 | 12.5 | 11.0 |
| 9.7 | 8.5 | 49 | 43 | 163 | 143 | | | 28.1 | 24.7 | 14.0 | 12.3 |
| 10.7 | 9.4 | 55 | 48 | 178 | 157 | 10.1 | 8.9 | 30.7 | 27.0 | 15.7 | 13.8 |
| 12.4 | 10.9 | 61 | 54 | 201 | 177 | 11.3 | 9.9 | 34.9 | 30.7 | 17.4 | 15.3 |
| 14.1 | 12.4 | 68 | 60 | 222 | 195 | 12.5 | 11.0 | 37.5 | 33.0 | 19.1 | 16.8 |
| 15.3 | 13.5 | 77 | 68 | 233 | 205 | 14.0 | 12.3 | 40.9 | 36.0 | 20.9 | 18.4 |
| 16.8 | 14.8 | 84 | 74 | 257 | 226 | 15.1 | 13.3 | 44.3 | 39.0 | 22.5 | 19.8 |
| 18.8 | 16.5 | 94 | 83 | | | 16.6 | 14.6 | 47.7 | 42.0 | 23.9 | 21.0 |
| 20.5 | 18.0 | 98 | 86 | | | 18.0 | 15.8 | 52.3 | 46.0 | 26.1 | 23.0 |
| 22.6 | 19.9 | 105 | 92 | | | 18.9 | 16.6 | 59.1 | 52.0 | 30.7 | 27.0 |
| 24.7 | 21.7 | 117 | 103 | | | 20.1 | 17.7 | 63.6 | 56.0 | 34.8 | 30.6 |
| 27.7 | 24.4 | | | | | 21.8 | 19.2 | 71.6 | 63.0 | 38.6 | 34.0 |
| | | | | | | 23.9 | 21.0 | 75.0 | 66.0 | 46.6 | 41.0 |
| | | | | | | 26.8 | 23.6 | 80.7 | 71.0 | | |
| | | | | | | 31.8 | 28.0 | | | | |
| | | | | | | 36.1 | 31.8 | | | | |
| | | | | | | 45.5 | 40.0 | | | | |
| NARROW | | WIDE | | WIDE | | NARROW | | NARROW | | NARROW | |
| 1 | | 2 | | 3 | | 1 | | 1 | | 1 | |
| -- | | 19 g | | 44 g | | -- | | -- | | 12 g | |

8.2 SEED DOSAGE TABLE (kg/ha)

| Adj. lever | WHEAT | | BARLEY | | TRITICALE | | PEAS | | BEANS | |
|------------------------------------|-------|------|--------|------|-----------|------|-------|-----|-------|------|
| | 12 | 13,5 | 12 | 13,5 | 12 | 13,5 | 24 | 27 | 12 | 13,5 |
| 14 | | | | | | | | | 82 | 72 |
| 16 | | | | | | | | | 98 | 86 |
| 18 | | | | | | | | | 117 | 103 |
| 20 | 90 | 79 | 70 | 62 | 68 | 60 | 46 | 41 | 139 | 122 |
| 22 | 102 | 89 | 79 | 69 | 75 | 66 | 52 | 46 | 155 | 136 |
| 24 | 113 | 100 | 87 | 76 | 83 | 73 | 55 | 49 | 171 | 150 |
| 26 | 122 | 108 | 97 | 85 | 90 | 79 | 62 | 55 | 195 | 172 |
| 28 | 134 | 118 | 105 | 92 | 99 | 87 | 68 | 60 | 214 | 188 |
| 30 | 142 | 125 | 114 | 101 | 107 | 95 | 75 | 66 | 232 | 204 |
| 32 | 150 | 132 | 122 | 108 | 118 | 104 | 79 | 69 | 252 | 222 |
| 34 | 161 | 141 | 132 | 116 | 129 | 114 | 83 | 73 | 269 | 237 |
| 36 | 171 | 150 | 142 | 125 | 141 | 124 | 89 | 78 | 292 | 257 |
| 38 | 180 | 159 | 150 | 132 | 150 | 132 | 94 | 82 | | |
| 40 | 191 | 168 | 159 | 140 | 159 | 140 | 98 | 86 | | |
| 45 | 214 | 188 | 180 | 159 | 176 | 154 | 103 | 91 | | |
| 50 | 236 | 207 | 199 | 175 | 192 | 169 | 112 | 99 | | |
| 55 | 259 | 228 | 228 | 200 | 211 | 186 | 117 | 103 | | |
| 60 | 282 | 248 | 239 | 210 | 230 | 202 | 126 | 111 | | |
| 65 | 305 | 268 | 259 | 228 | 248 | 219 | 155 | 136 | | |
| 70 | 329 | 290 | 277 | 244 | 267 | 235 | 168 | 147 | | |
| 75 | 352 | 310 | 298 | 262 | 285 | 251 | 179 | 158 | | |
| 80 | 377 | 331 | 315 | 277 | 304 | 267 | | | | |
| 85 | 396 | 349 | 335 | 295 | 321 | 283 | | | | |
| 90 | 418 | 368 | 352 | 310 | 341 | 300 | | | | |
| 95 | 440 | 387 | 372 | 327 | 359 | 316 | | | | |
| 100 | 464 | 409 | 390 | 344 | 379 | 333 | | | | |
| dispenser position | WIDE | | | | WIDE | | | | WIDE | |
| Palanca fondo móvil en el nº | 3 | | 3 | | 3 | | 4 | | 5 | |
| Peso operativo de 1000 granos | 40 g | | 46 g | | 30 g | | 293 g | | 530 g | |

TRI-194/R AND TRI-294/R**Wheels 10.80-12**

| RAPE | | SAINFOIN | | VESCE | | RAY-GRAS | | LUCERNE | | SPINACH | |
|--------|------|----------|------|-------|------|----------|------|---------|------|---------|------|
| 24 | 27 | 12 | 13,5 | 12 | 13,5 | 12 | 13,5 | 12 | 13,5 | 12 | 13,5 |
| 4.1 | 3.6 | 25 | 22 | 77 | 68 | | | 13.9 | 12.2 | 6.0 | 5.3 |
| 5.4 | 4.8 | 30 | 26 | 94 | 82 | | | 16.9 | 14.8 | 7.2 | 6.3 |
| 6.1 | 5.4 | 36 | 31 | 113 | 100 | | | 20.4 | 18.0 | 8.9 | 7.8 |
| 7.2 | 6.3 | 40 | 36 | 131 | 115 | | | 23.1 | 20.3 | 10.6 | 9.4 |
| 8.7 | 7.6 | 45 | 40 | 150 | 132 | | | 26.5 | 23.3 | 12.7 | 11.2 |
| 9.8 | 8.6 | 50 | 44 | 165 | 145 | | | 28.5 | 25.1 | 14.2 | 12.5 |
| 10.9 | 9.6 | 55 | 49 | 181 | 160 | 10.3 | 9.0 | 31.2 | 27.4 | 15.9 | 14.0 |
| 12.6 | 11.1 | 62 | 55 | 204 | 180 | 11.4 | 10.1 | 35.5 | 31.2 | 17.7 | 15.6 |
| 14.3 | 12.6 | 69 | 61 | 225 | 198 | 12.7 | 11.2 | 38.1 | 33.5 | 19.4 | 17.1 |
| 15.6 | 13.7 | 79 | 69 | 237 | 208 | 14.2 | 12.5 | 41.6 | 36.6 | 21.3 | 18.7 |
| 17.1 | 15.0 | 86 | 75 | 261 | 230 | 15.4 | 13.5 | 45.0 | 39.6 | 22.9 | 20.1 |
| 19.1 | 16.8 | 96 | 84 | | | 16.9 | 14.8 | 48.5 | 42.7 | 24.3 | 21.3 |
| 20.8 | 18.3 | 99 | 87 | | | 18.2 | 16.1 | 53.1 | 46.8 | 26.6 | 23.4 |
| 23.0 | 20.2 | 106 | 94 | | | 19.2 | 16.9 | 60.1 | 52.9 | 31.2 | 27.4 |
| 25.1 | 22.1 | 119 | 105 | | | 20.4 | 18.0 | 64.7 | 56.9 | 35.3 | 31.1 |
| 28.2 | 24.8 | | | | | 22.2 | 19.5 | 72.8 | 64.0 | 39.3 | 34.6 |
| | | | | | | 24.3 | 21.3 | 76.2 | 67.1 | 47.4 | 41.7 |
| | | | | | | 27.3 | 24.0 | 82.0 | 72.2 | | |
| | | | | | | 32.3 | 28.5 | | | | |
| | | | | | | 36.7 | 32.3 | | | | |
| | | | | | | 46.2 | 40.7 | | | | |
| NARROW | | WIDE | | WIDE | | NARROW | | NARROW | | NARROW | |
| 1 | | 2 | | 3 | | 1 | | 1 | | 1 | |
| -- | | 19 g | | 44 g | | -- | | -- | | 12 g | |

8.3 SEED DOSAGE TABLE (kg/ha)

| | WHEAT | BARLEY | TRITICALE | PEAS | BEANS |
|------------------------------------|-------|--------|-----------|-------|-------|
| arms dis. (cm) Adj. lever | 16 cm | 16 cm | 16 cm | 32 cm | 16 cm |
| 14 | | | | | 61,3 |
| 16 | | | | | 73,4 |
| 18 | | | | | 87,2 |
| 20 | 67,4 | 52,7 | 51,0 | 36,4 | 103,6 |
| 22 | 76,0 | 58,7 | 56,1 | 40,9 | 115,7 |
| 24 | 84,6 | 64,8 | 62,2 | 43,6 | 127,8 |
| 26 | 91,5 | 72,5 | 67,4 | 49,1 | 146,0 |
| 28 | 100,2 | 78,6 | 74,3 | 53,6 | 159,8 |
| 30 | 106,2 | 85,5 | 80,3 | 59,1 | 173,6 |
| 32 | 119,2 | 91,5 | 88,1 | 61,8 | 188,3 |
| 34 | 120,0 | 98,5 | 96,7 | 65,5 | 201,2 |
| 36 | 127,8 | 106,2 | 105,4 | 70,0 | 218,5 |
| 38 | 134,7 | 112,3 | 112,3 | 73,6 | |
| 40 | 142,5 | 119,2 | 119,2 | 77,3 | |
| 45 | 159,8 | 134,7 | 131,3 | 80,9 | |
| 50 | 176,2 | 148,5 | 143,3 | 88,2 | |
| 55 | 193,5 | 170,1 | 158,0 | 91,8 | |
| 60 | 210,7 | 178,8 | 171,9 | 99,1 | |
| 65 | 228,0 | 193,5 | 185,7 | 121,8 | |
| 70 | 246,1 | 207,3 | 199,5 | 131,8 | |
| 75 | 263,4 | 222,8 | 213,3 | 140,9 | |
| 80 | 281,5 | 235,8 | 227,1 | | |
| 85 | 296,2 | 250,5 | 240,1 | | |
| 90 | 312,6 | 263,4 | 254,8 | | |
| 95 | 329,0 | 278,1 | 268,6 | | |
| 100 | 347,2 | 291,9 | 283,3 | | |
| dispensers position | WIDE | WIDE | WIDE | WIDE | WIDE |
| mobile bottom lever position | 3 | 3 | 3 | 4 | 5 |
| 1000 grains operative weight | 40 g | 46 g | 30 g | 293 g | 530 g |

TRI-294/R-ESP**Wheels 6.00-16**

| | RAPE | VESCE | RAY-GRAS | LUCE R | SPINACH |
|------------------------------|--------|-------|----------|--------|---------|
| arms adj. Adj. lever (cm) | 32 cm | 16 cm | 16 cm | 16 cm | 16 cm |
| 14 | 3,2 | 57,9 | | 10,4 | 4,5 |
| 16 | 4,3 | 70,0 | | 12,6 | 5,4 |
| 18 | 4,8 | 84,6 | | 15,3 | 6,7 |
| 20 | 5,6 | 97,6 | | 17,3 | 7,9 |
| 22 | 6,8 | 112,3 | | 19,8 | 9,5 |
| 24 | 7,7 | 123,5 | | 21,3 | 10,6 |
| 26 | 8,5 | 135,6 | 7,7 | 23,3 | 11,9 |
| 28 | 9,9 | 152,9 | 8,6 | 26,5 | 13,2 |
| 30 | 11,3 | 168,4 | 9,5 | 28,5 | 14,5 |
| 32 | 12,3 | 177,0 | 10,6 | 31,1 | 15,9 |
| 34 | 13,5 | 195,2 | 11,5 | 33,7 | 17,1 |
| 36 | 15,0 | | 12,6 | 36,3 | 18,1 |
| 38 | 16,4 | | 13,7 | 39,7 | 19,9 |
| 40 | 18,1 | | 14,3 | 44,9 | 23,3 |
| 45 | 19,7 | | 15,3 | 48,4 | 26,4 |
| 50 | 22,2 | | 16,6 | 54,4 | 29,4 |
| 55 | | | 18,1 | 57,0 | 35,4 |
| 60 | | | 20,4 | 61,3 | |
| 65 | | | 24,2 | | |
| 70 | | | 27,5 | | |
| 75 | | | 34,6 | | |
| 80 | | | | | |
| 85 | | | | | |
| 90 | | | | | |
| 95 | | | | | |
| 100 | | | | | |
| dispensers position | NARROW | WIDE | WIDE | WIDE | NARROW |
| Mobile bottom position | 1 | 3 | 1 | 1 | 1 |
| 1000 grains operative weight | | 44 g | | | 12 g |

8.3 DOSAGE TABLE. FERTILIZER

Fertilizer dosage (kg/ha)

| sector N° | TRI-194/R-294/R wheels 6.00-16 | | TRI-194/R-294/R wheels 10.80-12 | | 294/R-ESP |
|-----------|-----------------------------------|-------|------------------------------------|-------|-----------|
| | 13,50 cm | 12 cm | 13,50 cm | 12 cm | 16 cm |
| 0 | 0 | 0 | 0 | 0 | 0 |
| 2 | 31 | 35 | 32 | 36 | 27 |
| 5 | 80 | 91 | 82 | 93 | 69 |
| 7 | 120 | 136 | 123 | 140 | 104 |
| 10 | 172 | 195 | 177 | 201 | 149 |
| 12 | 222 | 252 | 228 | 259 | 192 |
| 15 | 275 | 313 | 283 | 322 | 238 |
| 17 | 329 | 374 | 338 | 384 | 284 |
| 20 | 386 | 439 | 397 | 451 | 333 |
| 22 | 439 | 499 | 451 | 513 | 379 |
| 25 | 498 | 566 | 512 | 582 | 430 |
| 27 | 551 | 626 | 566 | 643 | 476 |
| 30 | 614 | 698 | 631 | 717 | 530 |
| 32 | 658 | 748 | 676 | 768 | 568 |
| 35 | 721 | 819 | 741 | 842 | 623 |
| 37 | 763 | 867 | 784 | 891 | 659 |
| 40 | 825 | 938 | 848 | 964 | 713 |
| 42 | 858 | 975 | 882 | 1002 | 741 |
| 45 | 918 | 1043 | 943 | 1072 | 793 |
| 47 | 947 | 1076 | 973 | 1106 | 714 |
| 50 | 987 | 1122 | 1014 | 1152 | 852 |

The combined machine only admits granulated fertilizers.



We suggest to use high concentration mixture fertilizer. Otherwise, the fertilizer hopper capacity would not be synchronized with that of the seed hopper.

9. SPARE PARTS

9.1 INTRODUCTION

The RIGHT, LEFT, FRONT and BACK denominations are referring to the machine working direction (fig. 41).

In the drawings, mirror parts are not repeated. Read the code in the codelist.

Do not forget to indicate the serial number and machine type in your spare parts order. Both informations are in the IDENTIFICATION PLATE. Do n

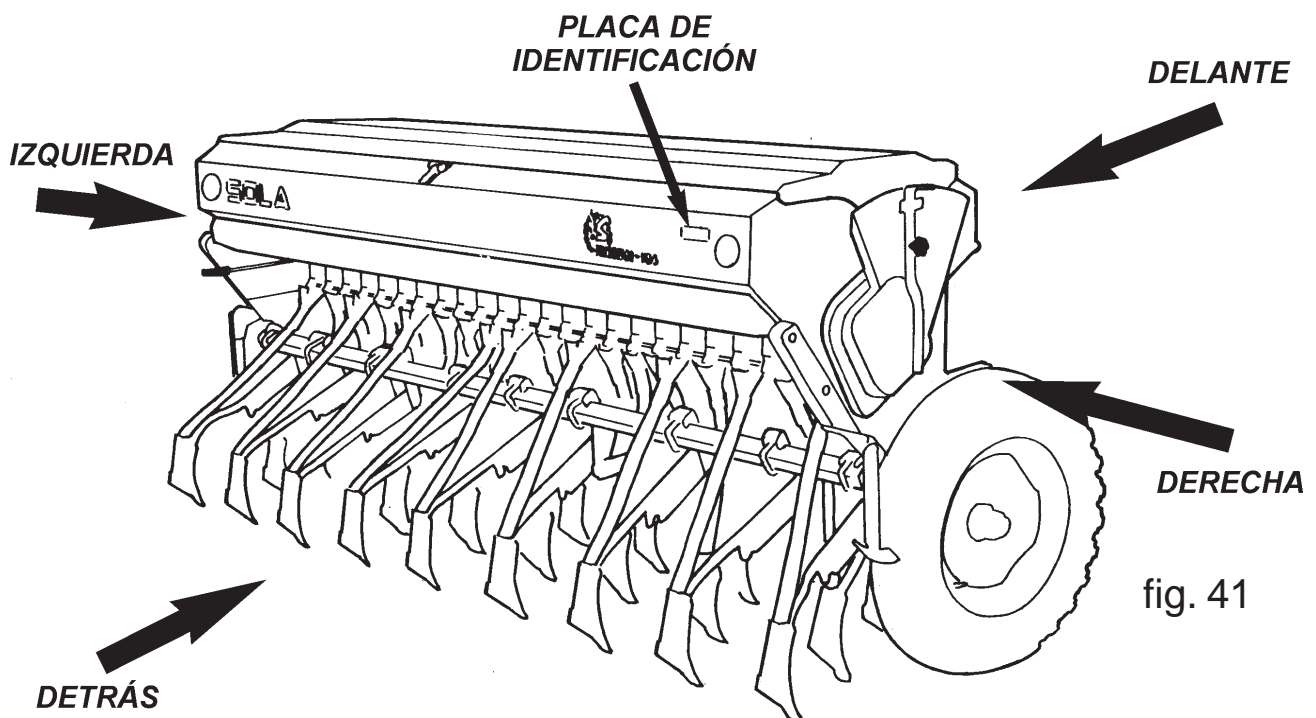

fig. 41



Do not forget that you could take injuries with sharp edges while replacing components or assembling optional equipment.



Avoid to work under the machine.
If you must do it, please secure it.

9.2 CHASSIS

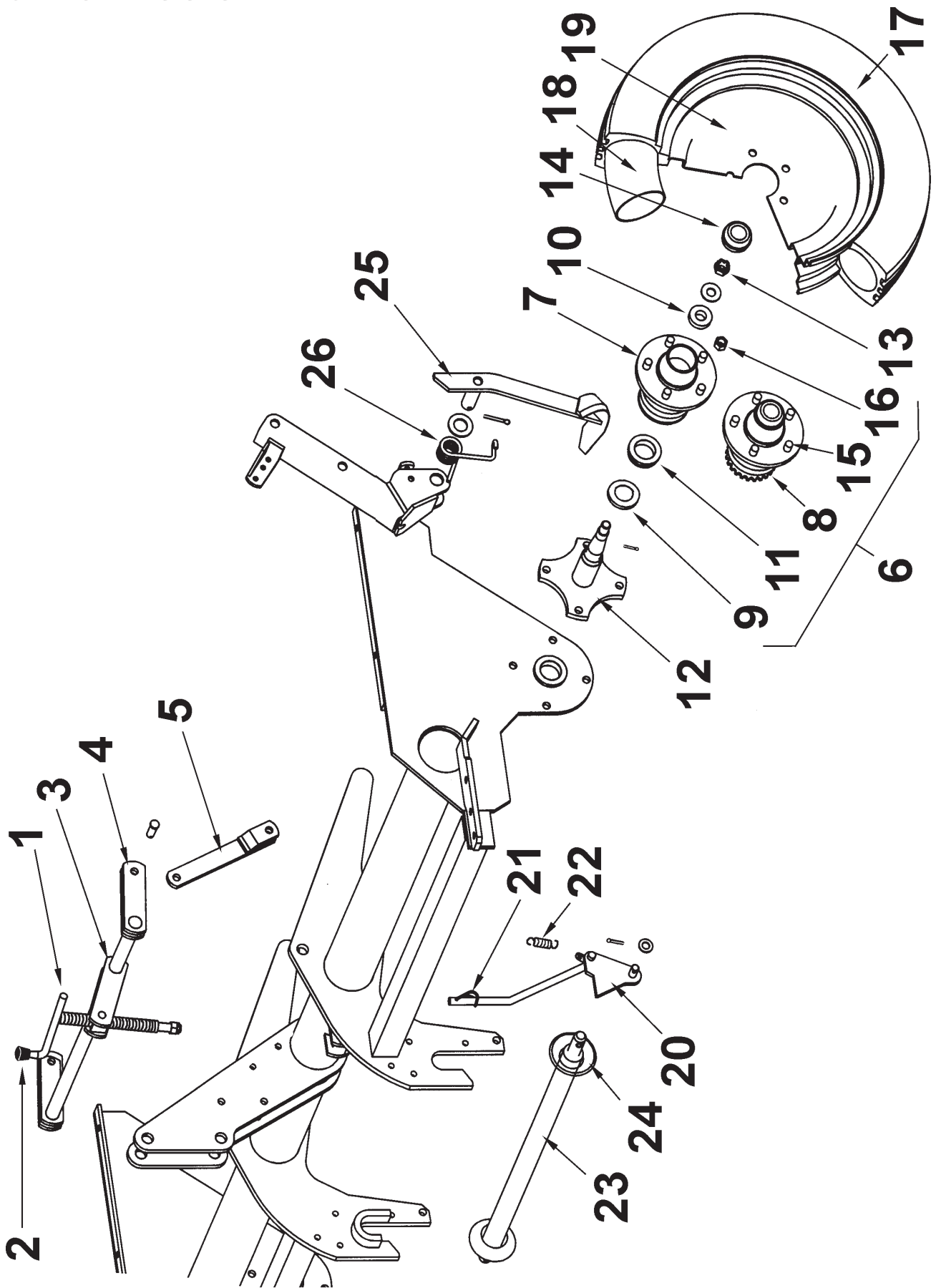

| Figure | Code | |
|--------|---------------|--|
| 1 | PS-0104 | |
| 2 | PL-010200 | |
| 3 | PS-2607 | |
| 4 | EE-040305 | |
| 5 | PS-2606 | |
| 6 | MO-040112 | |
| 6 | MO-040111 | |
| 6 | RE-040300 | |
| 6 | MO-040110 | |
| 6 | MO-040105 | |
| 6 | RE-040301 | |
| 7 | ME-040211 | |
| 7 | ME-040212 | |
| 8 | ME-040209 | |
| 8 | ME-040210 | |
| 9 | FE-601009 | |
| 9 | FE-601001 | |
| 10 | FE-600021 | |
| 10 | FE-600020 | |
| 10 | FE-600007 | |
| 11 | FE-600023 | |
| 11 | FE-600022 | |
| 11 | FE-600006 | |
| 12 | PS-2668 | |
| 12 | PS-2669 | |
| 12 | PS-2670 | |
| 13 | 935 20/150 | |
| 13 | 935 27/150 | |
| 14 | EE-040231 | |
| 14 | EE-040234 | |
| 15 | FE-614000 | |
| 16 | 917 16/150 BI | |
| 17 | PL-040300 | |
| 17 | PL-040301 | |
| 18 | PL-040302 | |
| 18 | PL-040303 | |
| 19 | CO-040303 | |
| 19 | CO-040302 | |
| 20 | PS-2602/D | |
| 20 | PS-2602/I | |
| 21 | ML-010100 | |
| 22 | ML-010101 | |
| 23 | PS-0108 | |
| 23 | PS-010102 | |
| 24 | EE-010226 | |
| 25 | PS-2604/D | |
| 25 | PS-2604/I | |
| 25 | PS-2605/D | |
| 25 | PS-2605/I | |
| 26 | ML-010300/D | |
| 26 | ML-010300/I | |

9.3 COULTER WORKING TRAIN

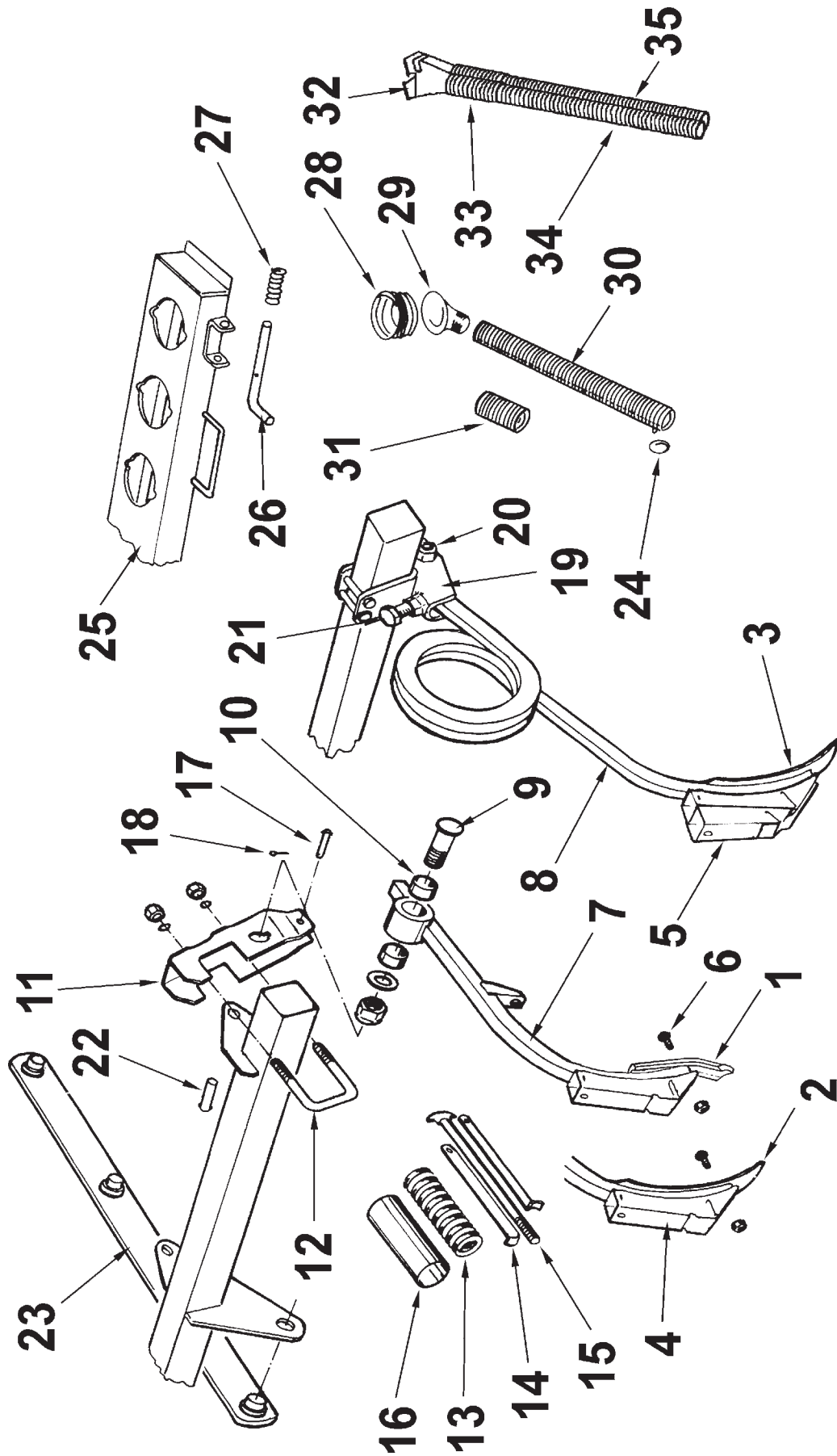

| Figure | Code | |
|--------|-----------------|--|
| 1 | FO-050300 | |
| 2 | FO-050301 | |
| 3 | FO-060300 | |
| 4 | MB-233 | |
| 5 | MB-164 | |
| 6 | 608/934 9X40 | |
| 7 | PS-2611 | |
| 7 | PS-2611/D | |
| 7 | PS-2611/I | |
| 8 | PS-2612/D | |
| 8 | PS-2612/I | |
| 8 | PS-2662/D | |
| 8 | PS-2662/I | |
| 9 | RE-050300 | |
| 10 | PL-050302 | |
| 11 | CO-050302 | |
| 12 | EE-050314 | |
| 13 | ML-050300 | |
| 14 | EE-050301 | |
| 15 | FO-050303 | |
| 16 | EE-050310 | |
| 17 | BU-050302 | |
| 18 | 94 3,5X20 BI | |
| 19 | MS-60 | |
| 20 | 933 16X45 8.8 B | |
| 21 | 933 12X50 8.8 B | |
| 22 | BU-050303 | |
| 23 | PS-2614 | |
| 24 | ML-050103 | |
| 25 | PS-1505/6/7/8 | |
| 26 | BU-050300 | |
| 27 | ML-050202 | |
| 28 | PL-050300 | |
| 29 | PL-050301 | |
| 30 | ML-050302 | |
| 30 | ML-050306 | |
| 30 | ML-050303 | |
| 30 | ML-050304 | |
| 30 | ML-050319 | |
| 30 | ML-050305 | |
| 31 | VA-1604 | |
| 31 | VA-1606 | |
| 32 | EE-050313 | |
| 32 | MB-114 | |
| 33 | VA-1613 | |
| 34 | ML-050313 | |
| 34 | ML-050110 | |
| 34 | ML-050323 | |
| 35 | ML-050311 | |
| 35 | ML-050107 | |
| 35 | ML-050324 | |

9.4 SEED VARIATOR

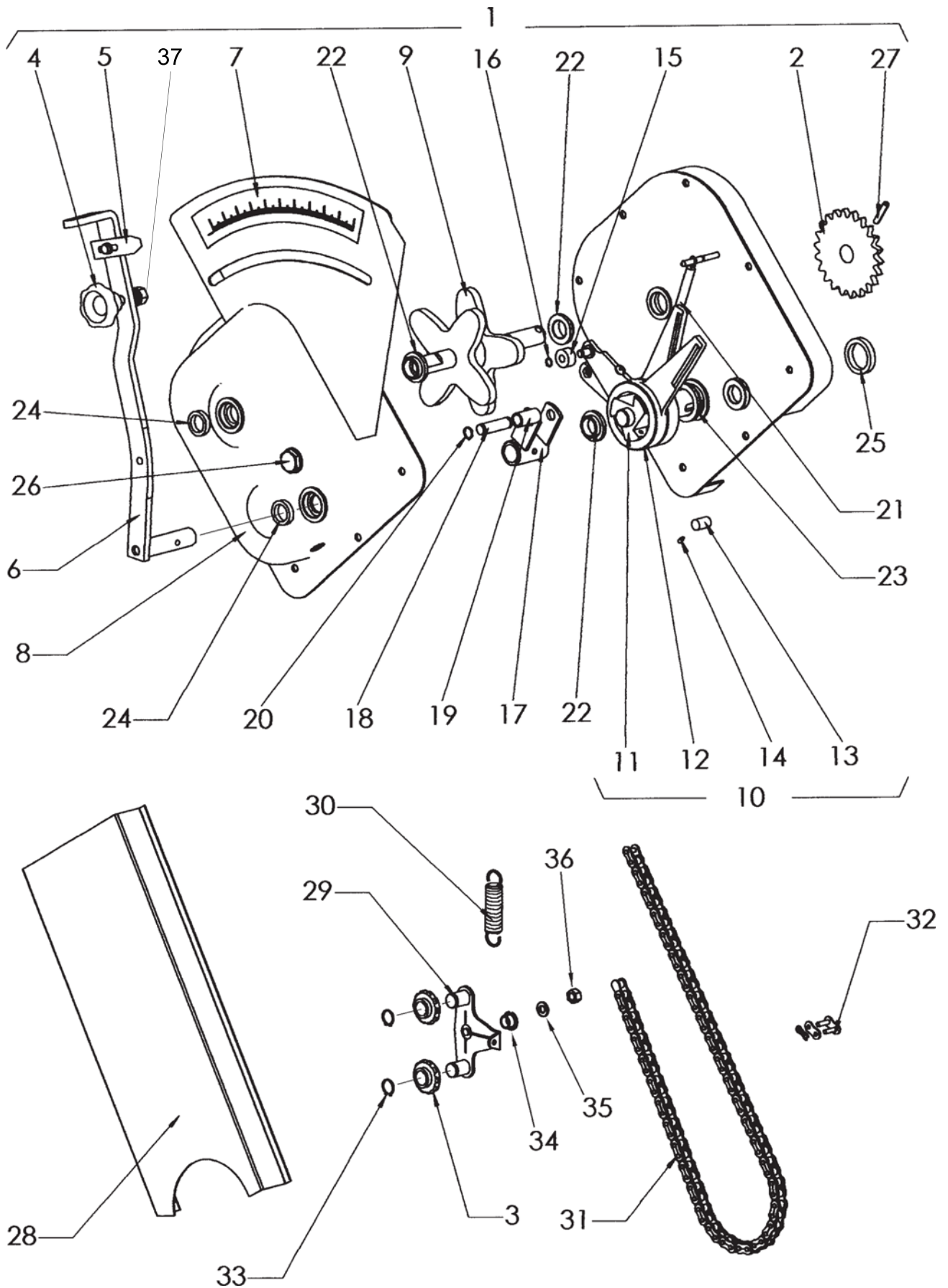

| Figure | Code | |
|--------|---------------|--|
| 1 | MO-0601 | |
| 2 | ME-040100 | |
| 3 | PL-040100 | |
| 4 | MV-09 | |
| 5 | PX-040204 | |
| 6 | PS-0610 | |
| 7 | AD-040200 | |
| 8 | PS-0618 | |
| 9 | TA-0618 | |
| 10 | MO-0605 | |
| 11 | RE-040201 | |
| 12 | ME-040226/D | |
| 12 | ME-040226/I | |
| 13 | RODILLO 12X18 | |
| 14 | RE-040202 | |
| 15 | PL-040200 | |
| 16 | 471 8 | |
| 17 | PS-0611 | |
| 18 | BU-040200 | |
| 19 | PL-040206 | |
| 20 | 471 12 | |
| 21 | ML-040101 | |
| 22 | PL-040207 | |
| 23 | PL-040208 | |
| 24 | FE-601004 | |
| 25 | FE-601005 | |
| 26 | HI-707005 | |
| 27 | 1481 6X40 BI | |
| 28 | PS-2641 | |
| 29 | CO-040300 | |
| 30 | ML-010101 | |
| 31 | FE-605008 | |
| 32 | FE-605025 | |
| 33 | 471 16 | |
| 34 | FE-600008 | |
| 35 | 125 8 BI | |
| 36 | 985 8 | |
| 37 | 985 10 I | |

9.5 FERTILIZER VARIATOR

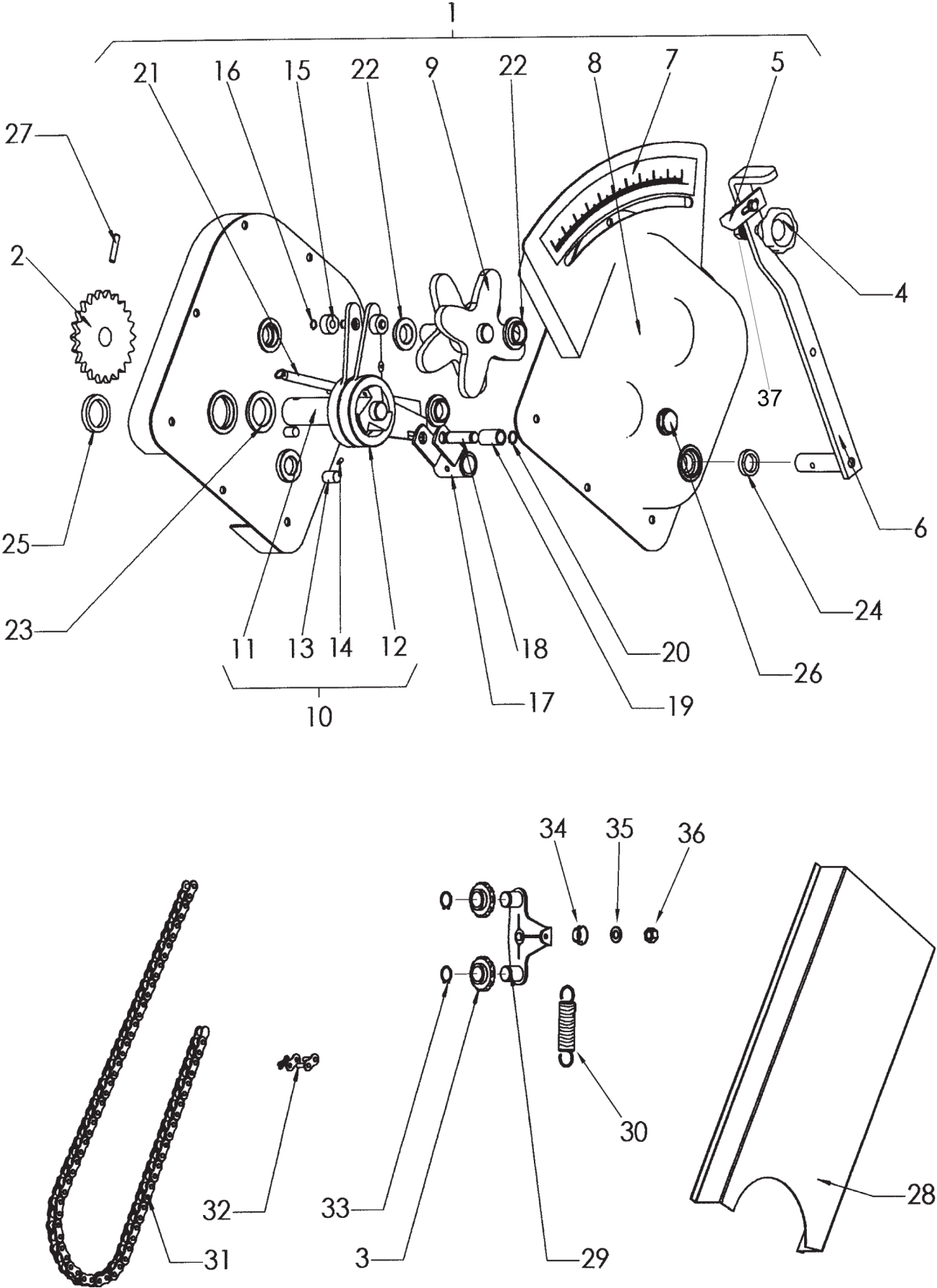

| Figure | Code | |
|--------|---------------|--|
| 1 | MO-0602 | |
| 2 | ME-040101 | |
| 3 | PL-040100 | |
| 4 | MV-09 | |
| 5 | PX-040204 | |
| 6 | PS-0619 | |
| 7 | AD-040201 | |
| 8 | PS-0627 | |
| 9 | RE-040200 | |
| 10 | MO-0606 | |
| 11 | RE-040203 | |
| 12 | ME-040232/D | |
| 12 | ME-040232/I | |
| 13 | RODILLO 12X18 | |
| 14 | RE-040202 | |
| 15 | PL-040200 | |
| 16 | 471 8 | |
| 17 | PS-0620 | |
| 18 | BU-040200 | |
| 19 | PL-040206 | |
| 20 | 471 12 | |
| 21 | ML-040101 | |
| 22 | PL-040207 | |
| 23 | PL-040208 | |
| 24 | FE-601004 | |
| 25 | FE-601005 | |
| 26 | HI-707005 | |
| 27 | 1481 6X30 BI | |
| 28 | PS-2642 | |
| 29 | CO-040300 | |
| 30 | ML-010101 | |
| 31 | FE-605009 | |
| 32 | FE-605025 | |
| 33 | 471 16 | |
| 34 | FE-600008 | |
| 35 | 125 8 BI | |
| 36 | 985 8 | |
| 37 | 985 10 I | |

9.6 SEED/FERTILIZER HOPPER

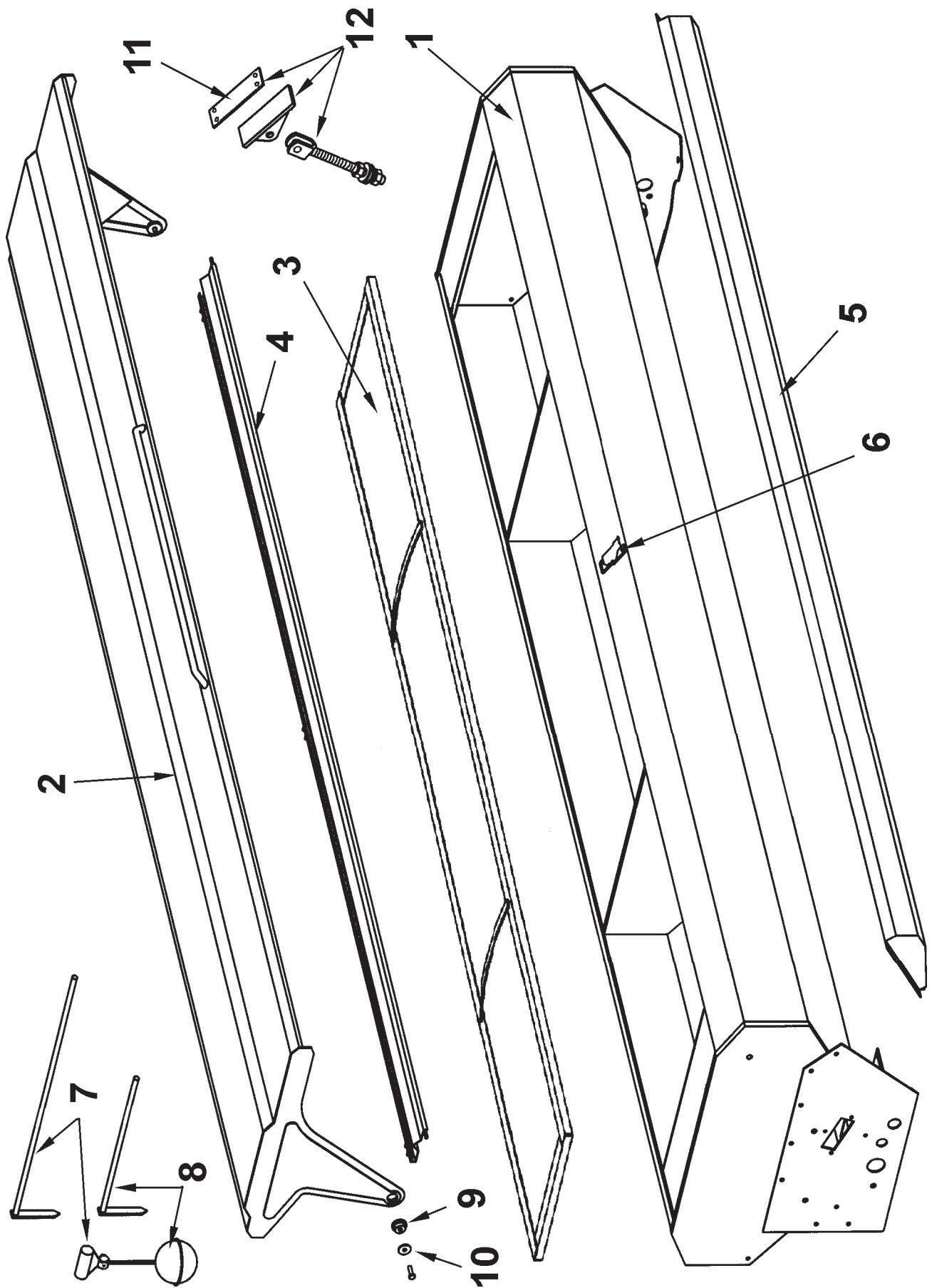

| Figure | Code | |
|--------|-----------|--|
| 1 | PS-0404 | |
| 1 | PS-0405 | |
| 1 | PS-0406 | |
| 1 | PS-0407 | |
| 1 | PS-0501 | |
| 1 | PS-0502 | |
| 1 | PS-0503 | |
| 1 | PS-0511 | |
| 1 | PS-2671 | |
| 1 | PS-2672 | |
| 1 | PS-2648 | |
| 1 | PS-2673 | |
| 1 | PS-2674 | |
| 1 | PS-2675 | |
| 1 | PS-2652 | |
| 1 | PS-2676 | |
| 2 | PS-1301 | |
| 2 | PS-1302 | |
| 2 | PS-1303 | |
| 2 | PS-1304 | |
| 3 | PS-1401 | |
| 3 | PS-1402 | |
| 3 | PS-1403 | |
| 3 | PS-1404 | |
| 4 | PS-1309 | |
| 4 | PS-1310 | |
| 4 | PS-1311 | |
| 4 | PS-1312 | |
| 4 | PS-1305 | |
| 4 | PS-1306 | |
| 4 | PS-1307 | |
| 4 | PS-1308 | |
| 5 | MB-60 | |
| 5 | MB-61 | |
| 5 | MB-62 | |
| 5 | MB-63 | |
| 6 | MO-1638 | |
| 7 | RE-020200 | |
| 8 | RE-020202 | |
| 9 | BU-020700 | |
| 10 | EE-030200 | |
| 11 | PL-020201 | |
| 12 | RE-020201 | |

9.7 SEED/FERTILIZER GC HOPPER

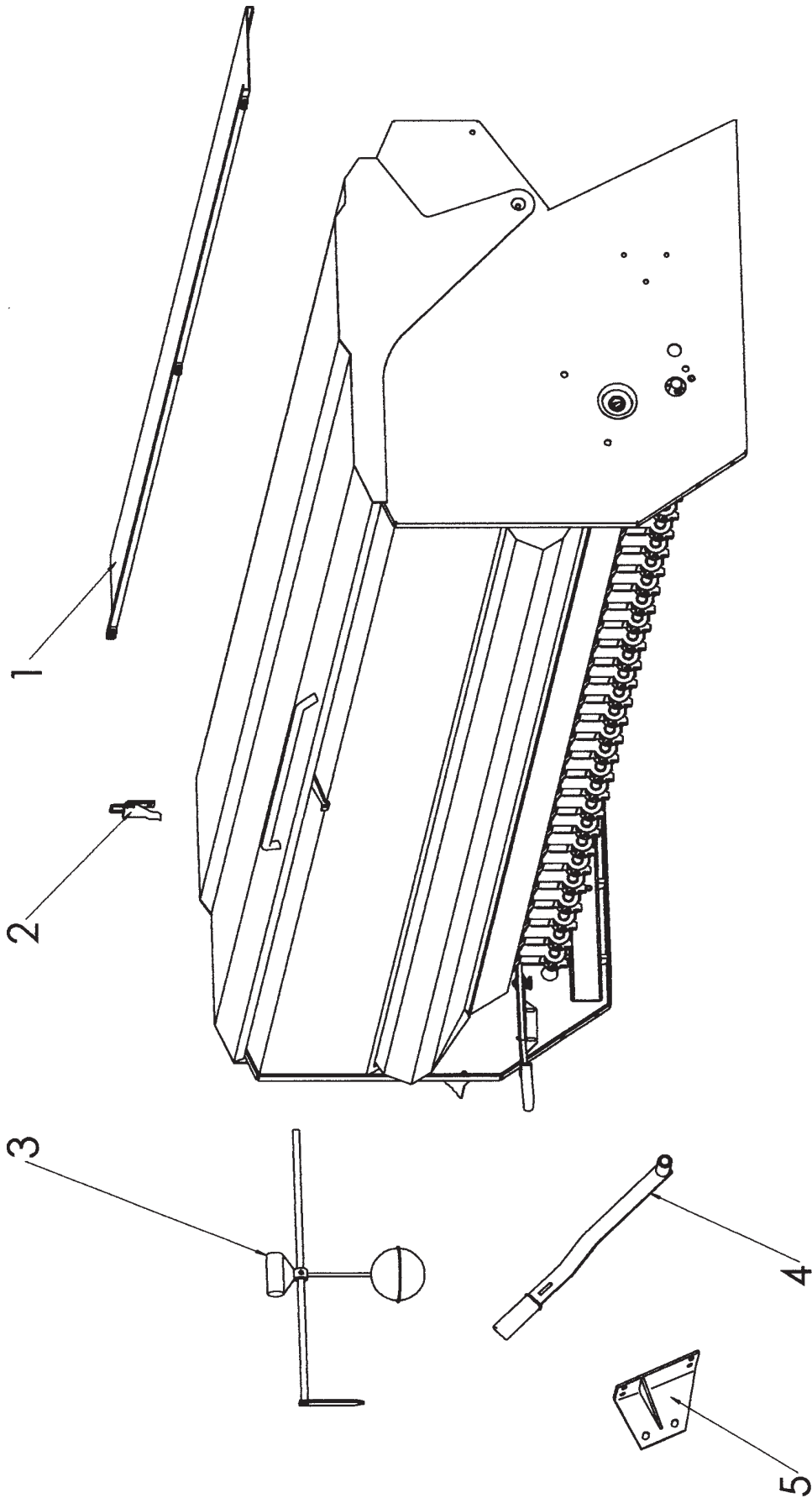

| Figure | Code | |
|--------|-------------|--|
| 1 | PS-030808 | |
| 1 | PS-030809 | |
| 1 | PS-030810 | |
| 2 | MO-1638 | |
| 3 | RE-021000 | |
| 4 | PS-020912 | |
| 5 | PS-021000/D | |
| 5 | PS-021000/I | |

9.8 SEED / FERTILIZER HOPPER

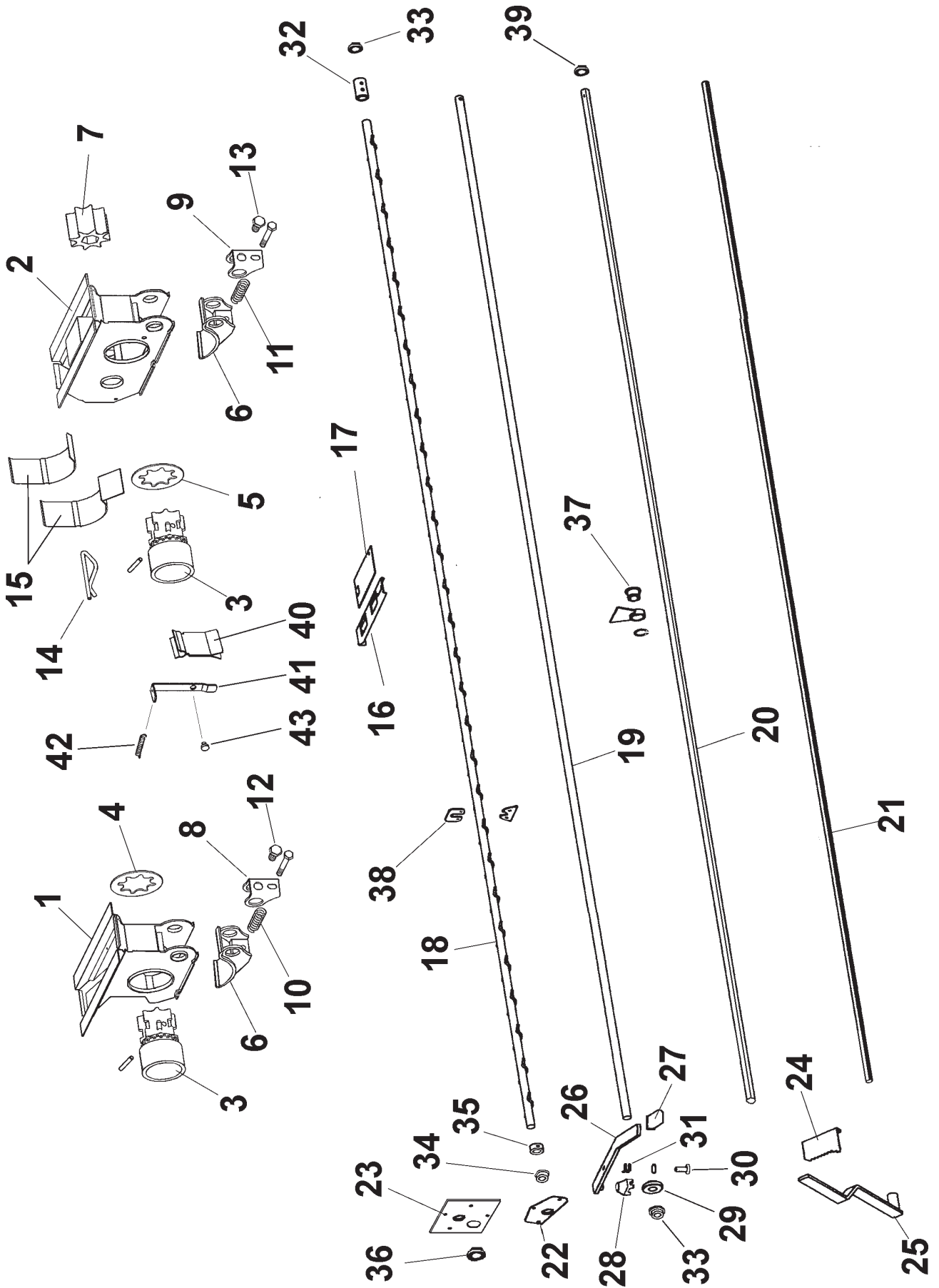

| Figure | Code | |
|--------|------------------|--|
| 1 | MD-11 | |
| 2 | MD-12 | |
| 3 | PL-040201 | |
| 4 | EE-040201 | |
| 5 | EE-040202 | |
| 6 | PL-040205 | |
| 7 | PL-040202 | |
| 8 | EE-040232 | |
| 9 | EE-040232/P | |
| 10 | ML-020200 | |
| 11 | ML-020201 | |
| 12 | 933 8X20B PUNTA | |
| 13 | 933 8x20I PUNTA | |
| 14 | ML-040203 | |
| 15 | EE-040227 | |
| 15 | EE-040226 | |
| 16 | EE-040228 | |
| 16 | EE-040229 | |
| 17 | EE-040230 | |
| 18 | TA-0402/16/17/18 | |
| 19 | PM-0408/09/10/11 | |
| 20 | TA-0506/07/08/12 | |
| 21 | PM-0402/12/13/14 | |
| 22 | EE-020215 | |
| 23 | PX-020218 | |
| 24 | EE-040219 | |
| 25 | PS-0410 | |
| 26 | PS-0408 | |
| 27 | PL-040203 | |
| 28 | ME-040223 | |
| 29 | ME-040214 | |
| 30 | BU-040208 | |
| 31 | ML-020202 | |
| 32 | ME-040227 | |
| 33 | PL-020204 | |
| 34 | PL-020205 | |
| 35 | ME-020202 | |
| 36 | PL-040208 | |
| 37 | PL-020203 | |
| 38 | EE-040215 | |
| 39 | PL-020206 | |
| 40 | EE-040303 | |
| 41 | EE-050201 | |
| 42 | ML-020100 | |
| 43 | EE-040100 | |

9.9 DISC MARKERS

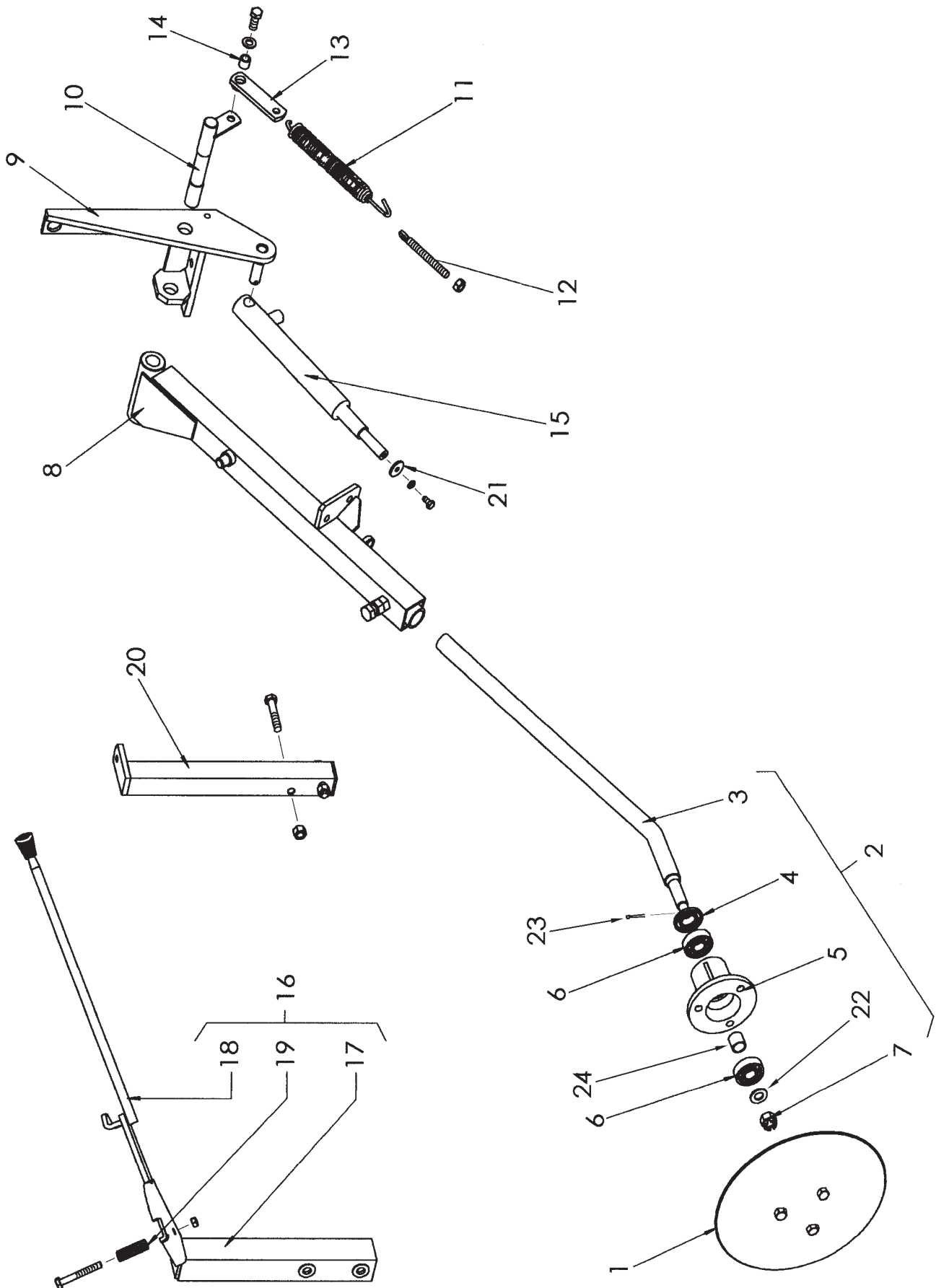

| Figure | Code | |
|--------|--------------|--|
| 1 | EE-100217 | |
| 2 | RE-100300 | |
| 3 | PR-100201 | |
| 4 | FE-601000 | |
| 5 | ME-100214 | |
| 6 | FE-600005 | |
| 7 | 935 16 BI | |
| 8 | PS-1803/D | |
| 8 | PS-1815/D | |
| 8 | PS-1803/I | |
| 8 | PS-1815/I | |
| 9 | PS-101303/D | |
| 9 | PS-101303/I | |
| 10 | PS-101304 | |
| 11 | ML-050201 | |
| 12 | EE-100219 | |
| 13 | PS-1805 | |
| 14 | ME-100200 | |
| 15 | CO-100200 | |
| 16 | MO-100305 | |
| 17 | PS-100301 | |
| 18 | PS-1810 | |
| 19 | ML-100700 | |
| 20 | PS-1812/D | |
| 20 | PS-1812/I | |
| 21 | EE-030200 | |
| 22 | 125 16 BI | |
| 23 | 94 3,5X28 BI | |
| 24 | CT-100800 | |

9.10 HARROW WITH FLEXIBLE TINES EPI-6

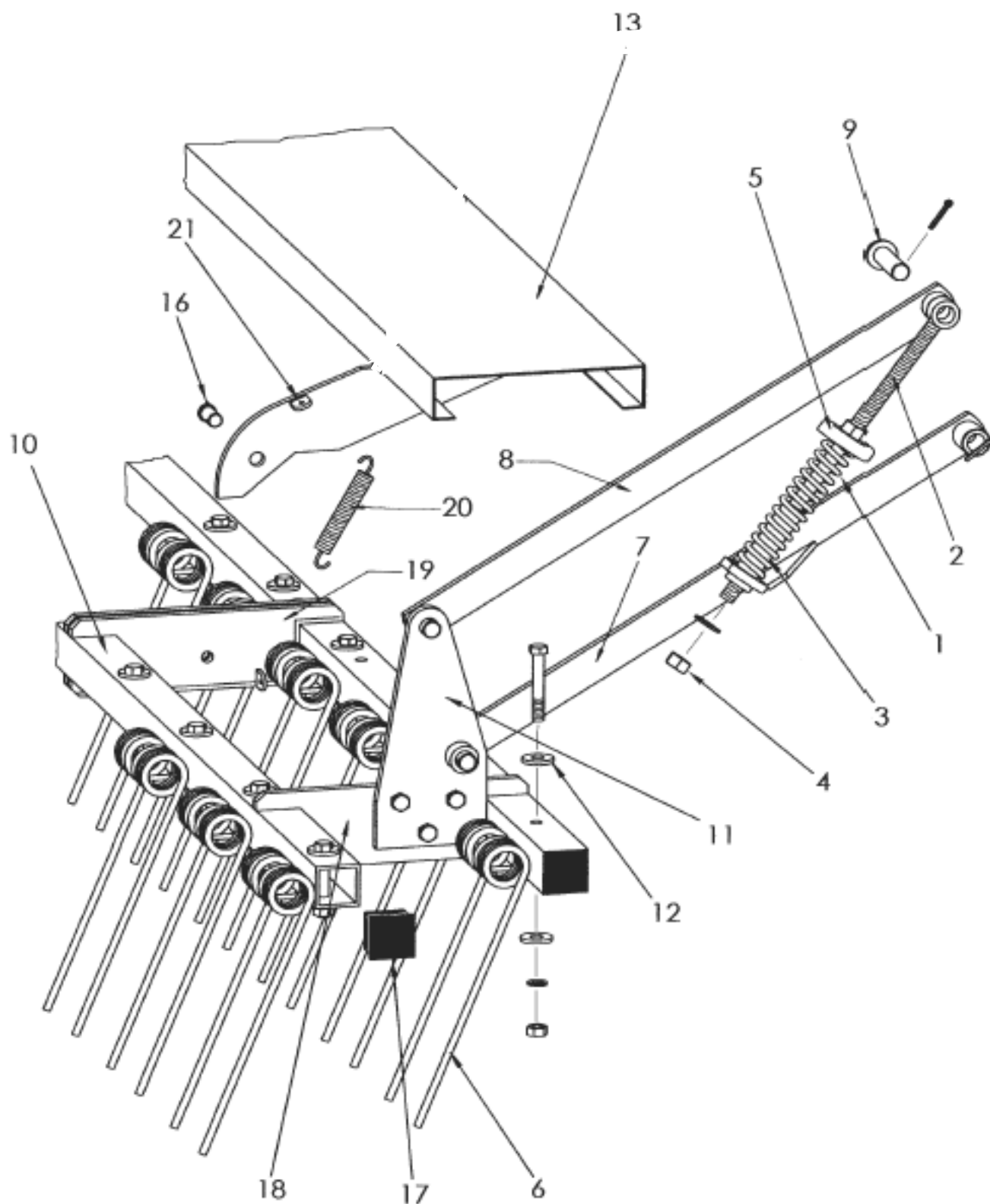

| Figure | Code | |
|--------|---------------|--|
| 1 | ML-080104 | |
| 2 | PS-1710 | |
| 3 | PS-1735 | |
| 4 | 985 16 | |
| 5 | EE-080306 | |
| 6 | ML-080103 | |
| 7 | PS-1741/D | |
| 7 | PS-1741/I | |
| 8 | PS-1734 | |
| 9 | BU-080202 | |
| 10 | PS-1736/37/38 | |
| 11 | PS-1736/D | |
| 11 | PS-1736/I | |
| 12 | ME-080202 | |
| 13 | PS-1740 | |
| 16 | BU-080206 | |
| 17 | CN-817001 | |
| 18 | PX-080207 | |
| 19 | PX-080201 | |
| 20 | ML-080101 | |
| 21 | EE-080206 | |

9.11 ARTICULATED HARROW 4 METRES EPI-7

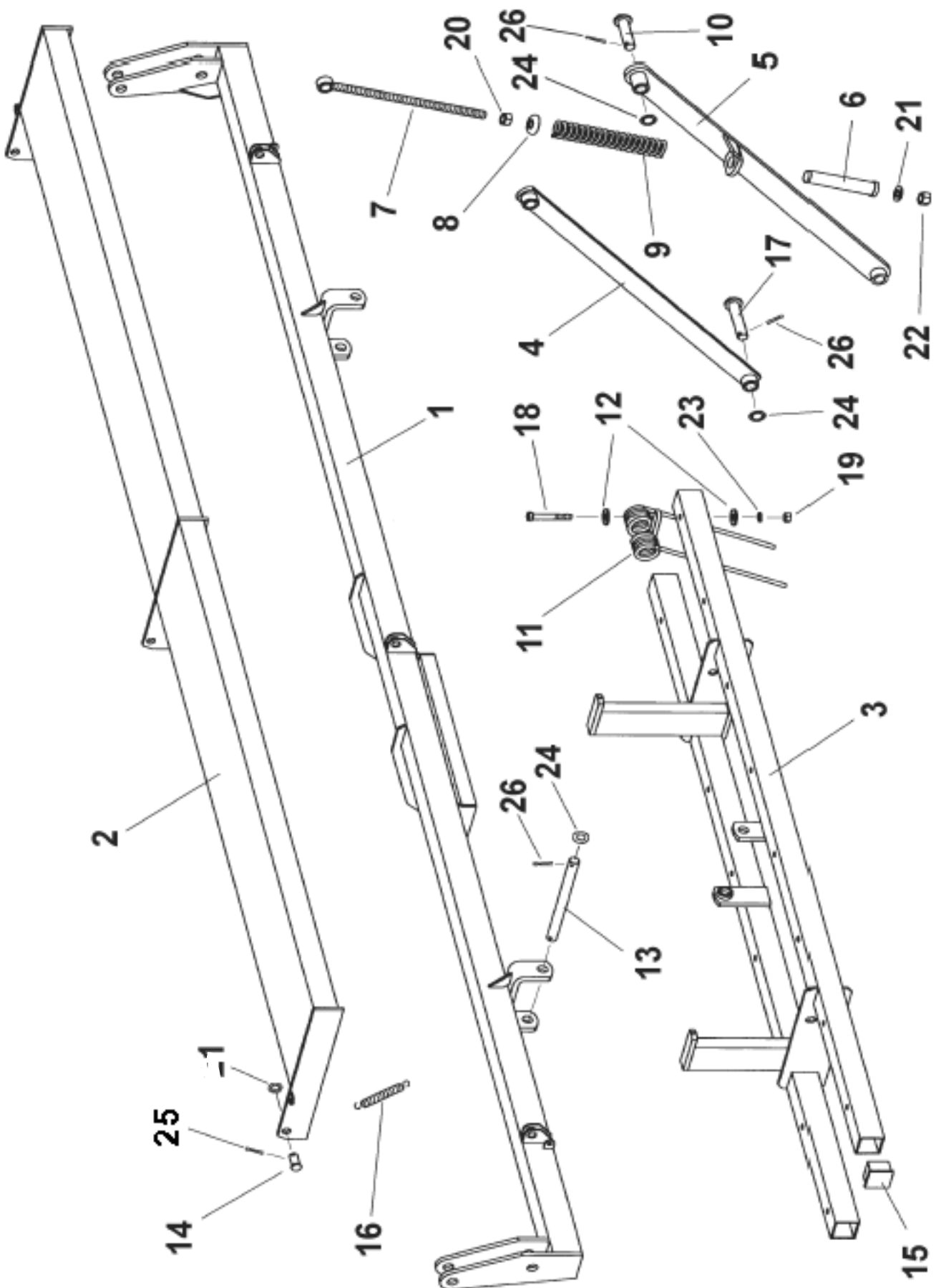

| Figure | Code | |
|--------|----------------|--|
| 1 | PS-080311 | |
| 2 | PS-080312 | |
| 3 | PS-080310 | |
| 4 | PS-080307 | |
| 5 | PS-080308/D | |
| 5 | PS-080308/I | |
| 6 | PS-1735 | |
| 7 | PS-080306 | |
| 8 | EE-080306 | |
| 9 | ML-080104 | |
| 10 | BU-080202 | |
| 11 | ML-080103 | |
| 12 | ME-080202 | |
| 13 | BU-080302 | |
| 14 | BU-080206 | |
| 15 | CN-817001 | |
| 16 | ML-080101 | |
| 17 | BU-080205 | |
| 18 | 931 12X80 8.8B | |
| 19 | 934 12 BI | |
| 20 | 934 16 BI | |
| 21 | 125 16 BI | |
| 22 | 985 16 | |
| 23 | 7980 12 BI | |
| 24 | 125 20 BI | |
| 25 | 94 5X25 BI | |
| 26 | 94 5X32 BI | |

9.12 HARROW TYPE «E»

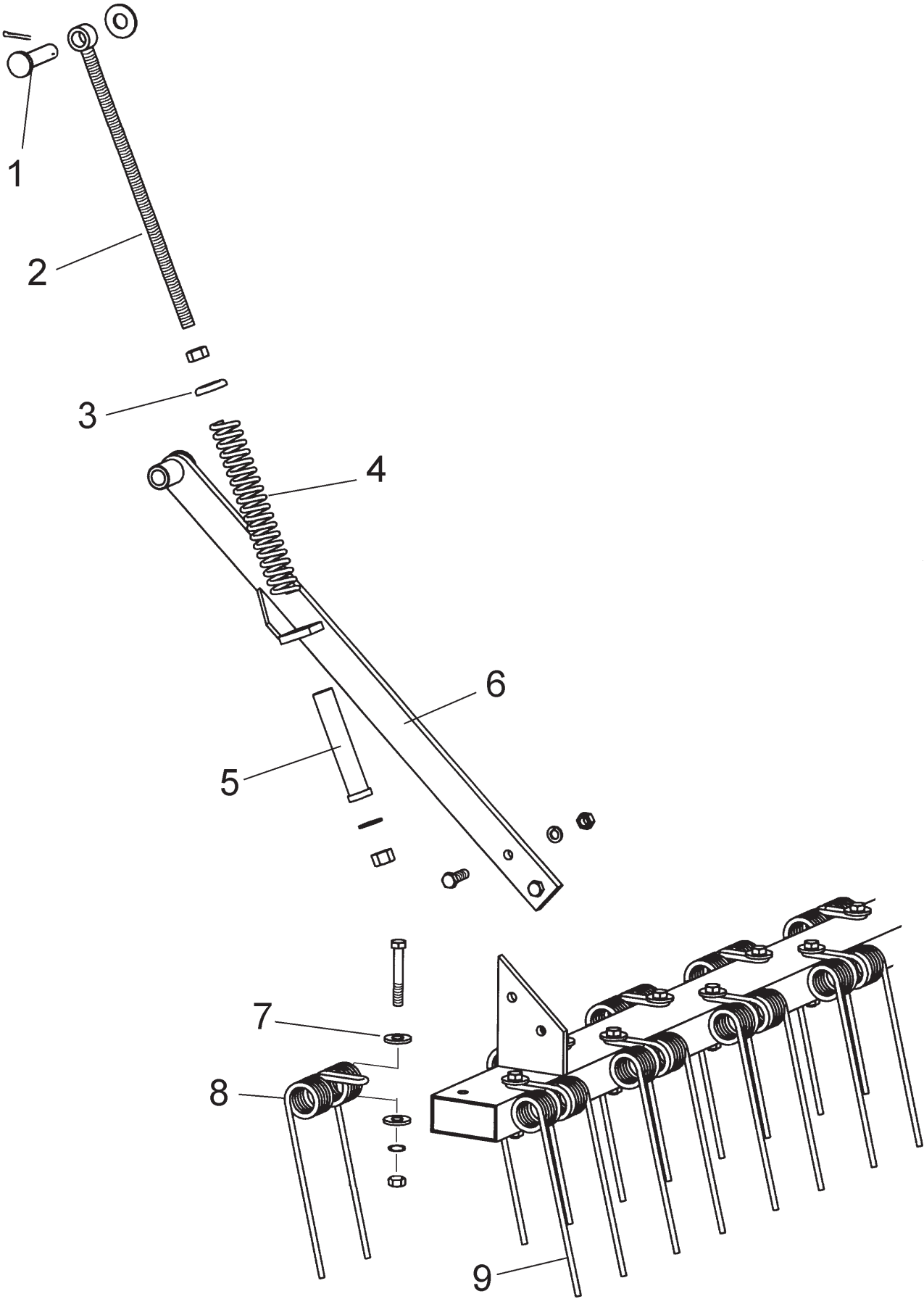

| Figure | Code | |
|--------|-----------|--|
| 1 | BU-080202 | |
| 2 | PS-1710 | |
| 3 | EE-080306 | |
| 4 | ML-080104 | |
| 5 | PS-1735 | |
| 6 | PS-2610/D | |
| 6 | PS-2610/I | |
| 7 | ME-080202 | |
| 8 | ML-080000 | |
| 9 | ML-080001 | |

9.13 WHEEL BREAKERS «RANSOME»

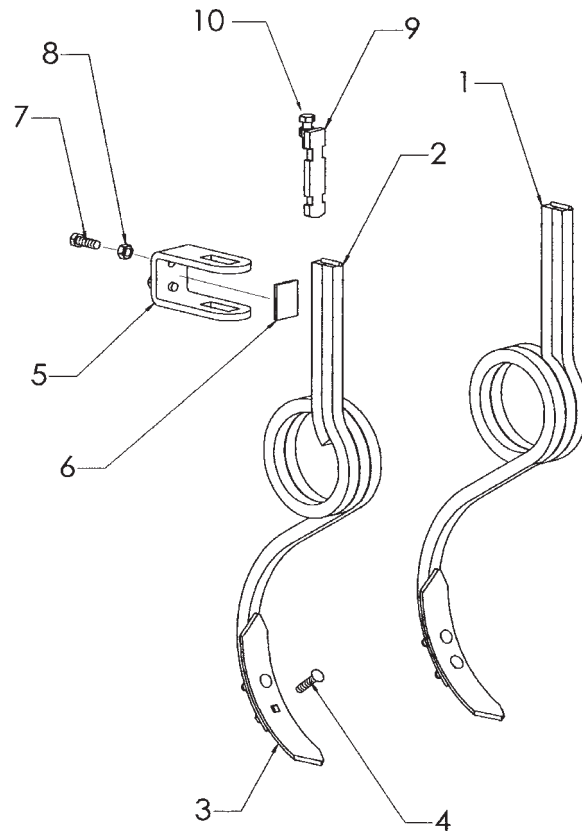

9.14 WHEEL BREAKERS «SPRING»

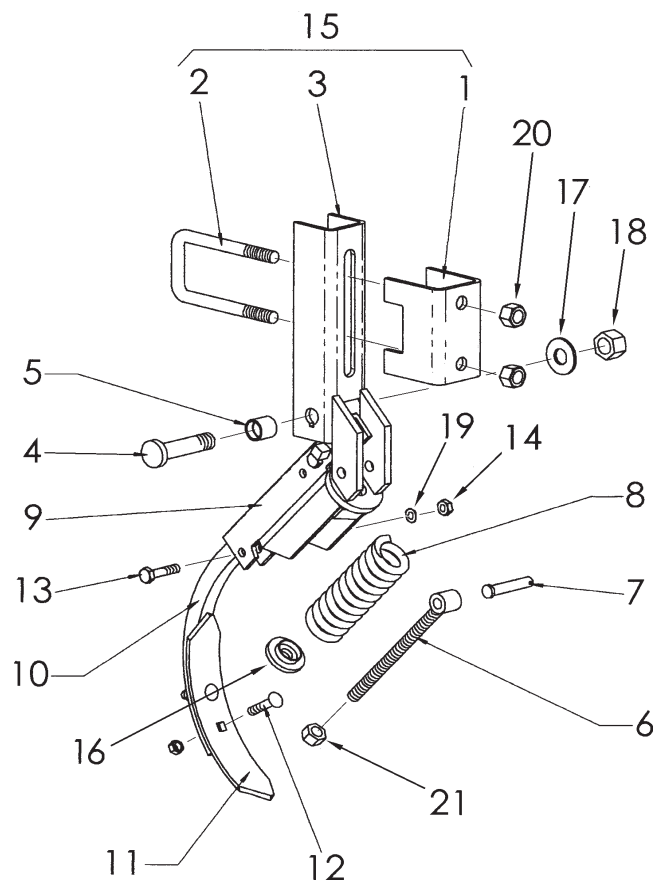

| Figure | Code | |
|--------|-----------------|--|
| 1 | PS-1105/D | |
| 2 | PS-1105/I | |
| 3 | FO-060300 | |
| 4 | 608/934 9X40 | |
| 5 | EE-060307 | |
| 6 | PX-060200 | |
| 7 | 933 12X35 8.8 B | |
| 8 | 934 12 BI | |
| 9 | CO-060200 | |
| 10 | 933 12X40 8.8 B | |

| Figure | Code | |
|--------|-----------------|--|
| 1 | PX-060201 | |
| 2 | EE-060228 | |
| 3 | PS-1113 | |
| 4 | EE-050312 | |
| 5 | PL-050302 | |
| 6 | FO-060202 | |
| 7 | BU-060300 | |
| 8 | ML-060300 | |
| 9 | PS-1120 | |
| 10 | FO-060302 | |
| 11 | FO-060300 | |
| 12 | 608/934 9X40 | |
| 13 | 931 10X45 8.8 B | |
| 14 | 934 10 | |
| 15 | MO-0719 | |
| 16 | PS-1115 | |
| 17 | 125 20 BI | |
| 18 | 985 20/150 | |
| 19 | 127 10 | |
| 20 | 985 16 | |
| 21 | 980 14 BI | |

9.15 CULTIVATOR

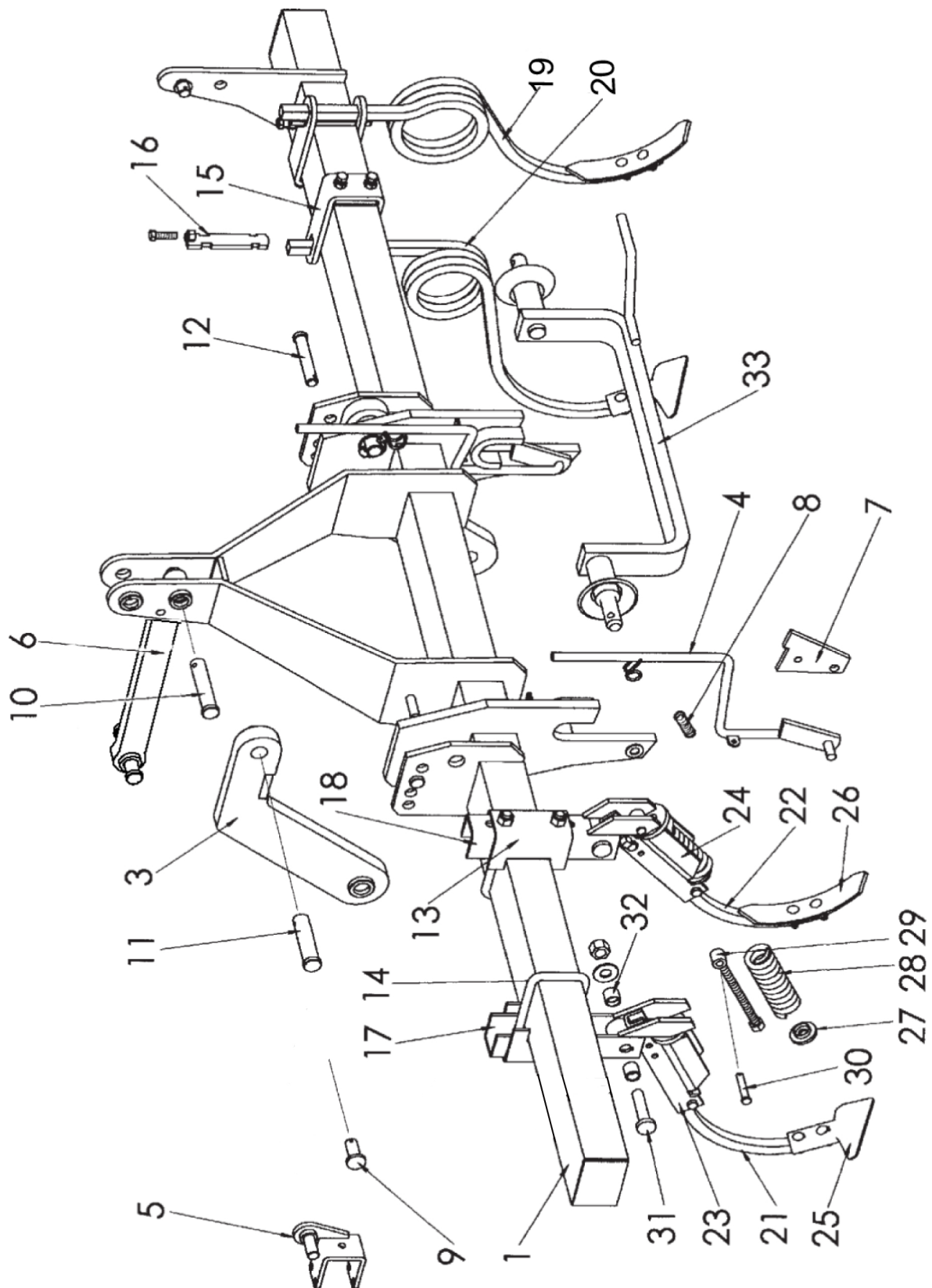

| Figure | Code | |
|--------|---------------|--|
| 1 | PS-0705/6/7/8 | |
| 3 | PS-0702/D | |
| 3 | PS-0702/I | |
| 4 | TA-060201/D | |
| 4 | TA-060201/I | |
| 6 | PS-060205 | |
| 7 | TA-0721 | |
| 8 | ML-010101 | |
| 10 | BU-060203 | |
| 11 | BU-060202 | |
| 12 | BU-060201 | |
| 13 | PX-060202 | |
| 14 | EE-060230 | |
| 15 | EE-060227 | |
| 16 | CO-060201 | |
| 17 | PS-1117 | |
| 18 | PS-1113 | |
| 19 | VA-060200/D | |
| 19 | VA-060200/I | |
| 20 | VA-060201/D | |
| 20 | VA-060201/I | |
| 21 | FO-060303 | |
| 22 | FO-060302 | |
| 23 | PS-1121 | |
| 24 | PS-1120 | |
| 25 | FO-060301 | |
| 26 | FO-060300 | |
| 27 | PS-1115 | |
| 28 | ML-060300 | |
| 29 | FO-060202 | |
| 30 | BU-060300 | |
| 31 | EE-050312 | |
| 32 | PL-050302 | |
| 33 | PS-0109 | |

9.16 LEVELER

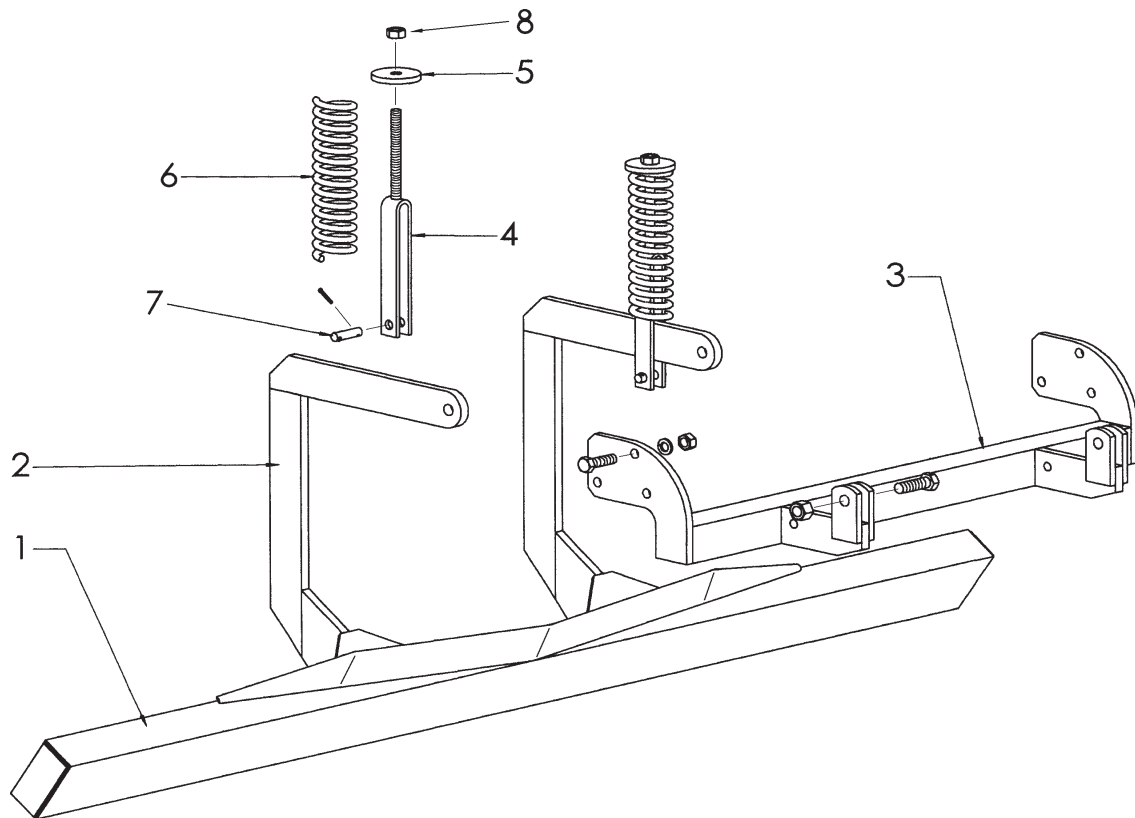

9.17 HECTARE COUNTER

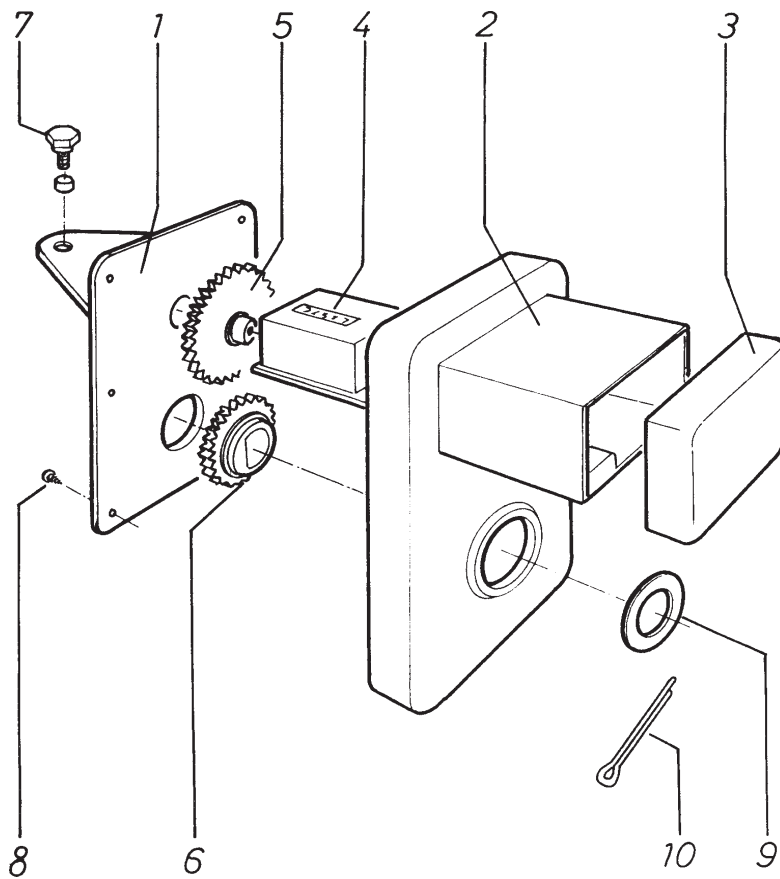

| Figure | Code | |
|--------|---------------|--|
| 1 | PS-2624/L | |
| 1 | PS-2624/C | |
| 2 | PS-2623 | |
| 3 | PS-2665/L | |
| 3 | PS-2665/C | |
| 4 | MB-13 | |
| 5 | EE-060303 | |
| 6 | ML-080100 | |
| 7 | BU-080702 | |
| 8 | 934 12/150 BI | |

| Figure | Code | |
|--------|---------------|--|
| 1 | PL-100200 | |
| 2 | TA-100102 | |
| 3 | PL-100201 | |
| 4 | MV-100200 | |
| 5 | PL-100300 | |
| 5 | PL-100301 | |
| 5 | PL-100101 | |
| 5 | PL-100303 | |
| 6 | PL-100304 | |
| 6 | PL-100305 | |
| 6 | PL-100105 | |
| 6 | PL-100307 | |
| 7 | ME-100211 | |
| 8 | 7971 7X3/8 BI | |
| 9 | 125 20 BI | |
| 10 | 94 3,5X28 BI | |

9.18 AUTOMATIC COUPLING

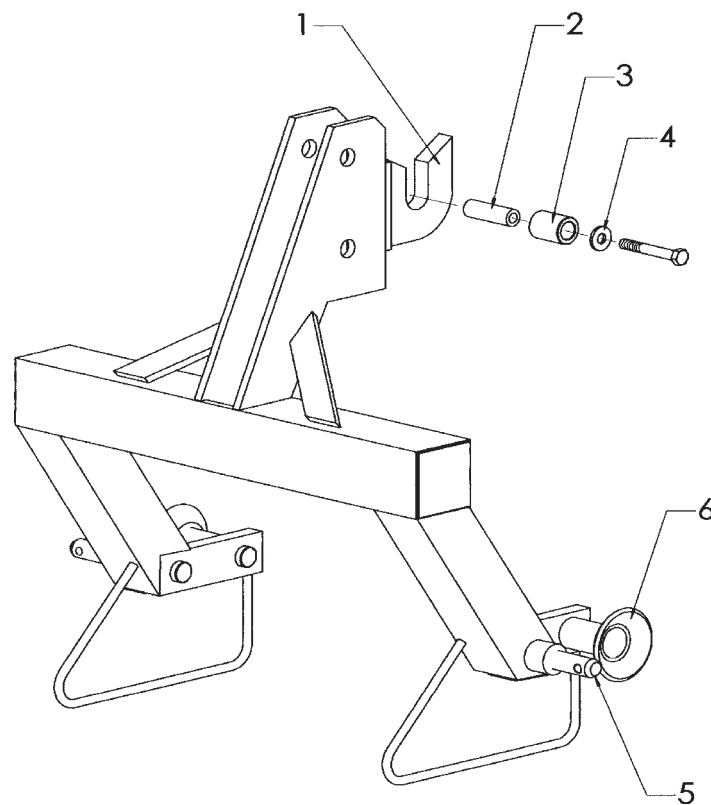

9.19 AUTOMATIC COUPLING. FLOATING CULTIVATOR

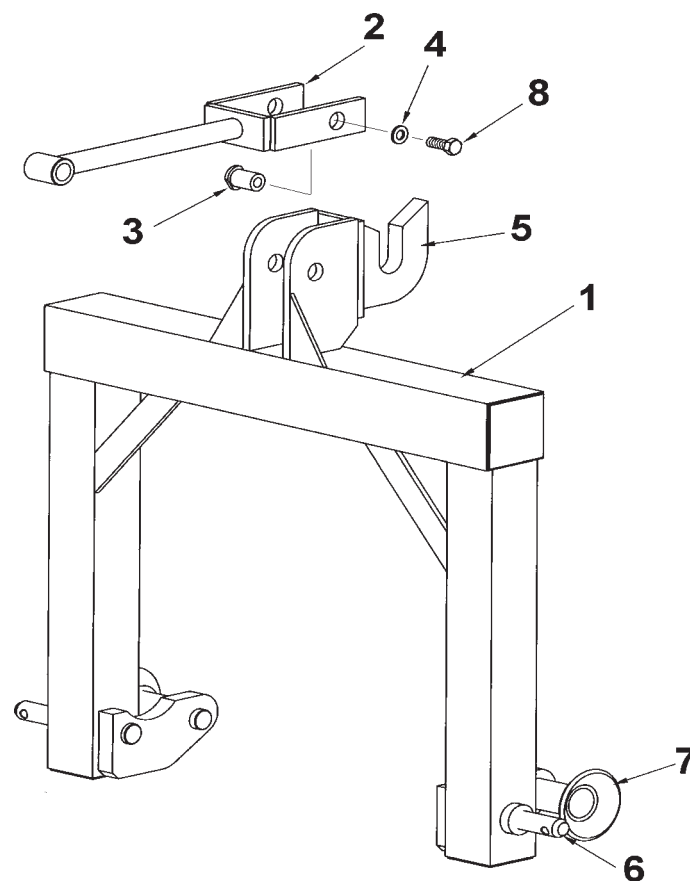

| Figure | Code | |
|--------|-----------|--|
| 1 | OX-100203 | |
| 2 | ME-100206 | |
| 2 | ME-100207 | |
| 3 | ME-060207 | |
| 4 | ME-080202 | |
| 5 | BU-010100 | |
| 6 | EE-010226 | |

| Figure | Code | |
|--------|----------------|--|
| 1 | PS-100202 | |
| 2 | PS-100201 | |
| 3 | ME-060209 | |
| 4 | ME-080202 | |
| 5 | OX-100203 | |
| 6 | BU-010100 | |
| 7 | EE-010226 | |
| 8 | 933 14X14 8.8B | |

9.20 FINISHINGS

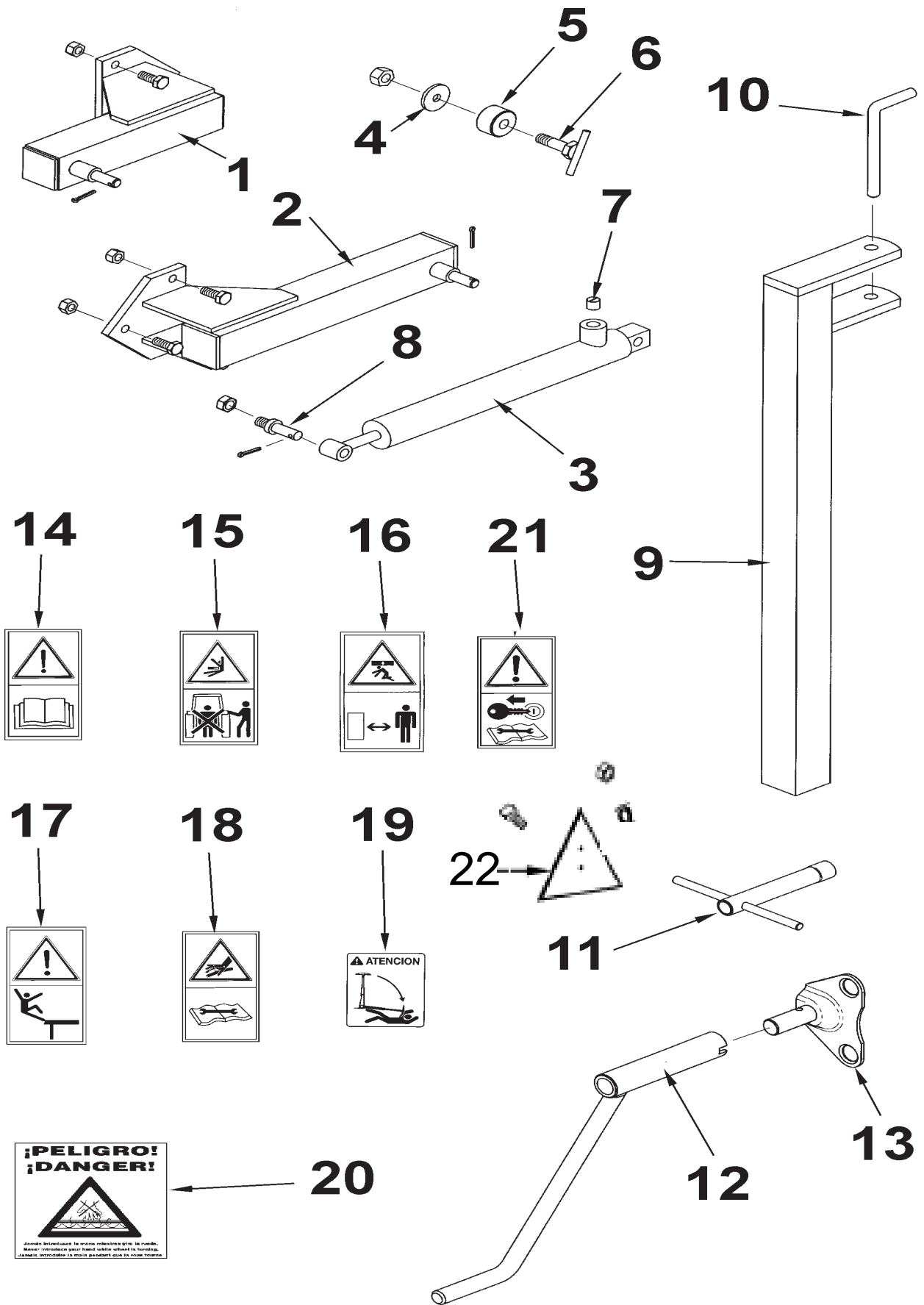

| Figure | Code | |
|--------|-----------|--|
| 1 | PS-0609 | |
| 2 | PS-0608 | |
| 3 | CO-100201 | |
| 4 | EE-030202 | |
| 5 | ME-100202 | |
| 6 | PS-0607 | |
| 7 | ME-100210 | |
| 8 | BU-100204 | |
| 9 | PS-2631 | |
| 9 | PS-1601 | |
| 10 | BU-070100 | |
| 11 | ML-12 | |
| 12 | CO-070300 | |
| 13 | MO-1637 | |
| 14 | AD-070206 | |
| 15 | AD-070214 | |
| 16 | AD-070207 | |
| 17 | AD-070215 | |
| 18 | AD-070222 | |
| 19 | AD-100200 | |
| 20 | AD-030200 | |
| 21. | AD-070227 | |
| 22 | CN-818019 | |

