



AURA-3215

Pressurized hopper



STARTING MANUAL

MAINTENANCE AND DOSAGE

WWW.SOLAGRUPO.COM

SOLÀ seed drills, planters and fertilizer spreaders are manufactured in a highly specialized environment and our factory has a vast network of satisfied customers.

SOLÀ machines use highly advanced technology and are guaranteed to work without malfunctions in a large variety of conditions. The **SOLÀ** machines are provided with easy-to-use and efficient devices and perform excellently with only minimum operator maintenance.

This manual will help you use your **SOLÀ** product with the maximum efficiency.



Certified quality system

1st Edition – March 2017

Ref.: CN-811105/GB

Created by: M.A. SOLÀ

It is forbidden to copy any part of this manual.

Specifications are subject to change or modification without notice.

The pictures included do not necessary show the standard version.

SUBJECT INDEX

1- INTRODUCTION.....	5
2- SAFETY INSTRUCTIONS.....	6
2.1 SAFETY SYMBOLS.....	6
2.2 GENERAL SAFETY DISPOSITIONS.....	6
2.3 USE DEPENDING ON DESIGN.....	7
2.4 LOADING AND UNLOADING INSTRUCTIONS.....	7
3. GENERAL DESCRIPTION.....	8
3.1 GENERAL OVERVIEW.....	8
3.2 TECHNICAL FEATURES.....	9
3.3 IDENTIFICATION OF THE MACHINE.....	9
4. COMMISSIONING.....	10
4.1 ASSEMBLY OF THE MACHINE TO THE TRACTOR.....	10
4.2 TRACTOR'S REQUIREMENTS.....	10
5. DOSAGE.....	11
5.1 DISPENSER TYPES.....	11
5.1.1 ROLLER DISPENSER.....	11
5.1.2 ENDLESS DISPENSER.....	12
5.1.3 TRANSFILLING DISPENSER.....	13
5.2 CALIBRATION TEST.....	13
5.3 DOSAGE GRAPHS.....	14
5.3.1 ROLLER DISPENSER.....	15
5.3.1.1 ROLLER DISPENSER WITH A SINGLE OUTLET.....	15
5.3.1.2 ROLLER DISPENSER WITH TWO OUTLETS.....	16
5.3.2 ENDLESS DISPENSER.....	17
5.3.2.1 ENDLESS DISPENSER WITH A SINGLE OUTLET.....	17
5.3.2.2 TWO ENDLESS DISPENSERS WITH TWO OUTLETS.....	17
6. USAGE ADVICE.....	18
6.1 AURA-3215 WITH PERFORMER.....	18
6.2 AURA-3215 WITH ISOBUS.....	18
7. MAINTENANCE.....	19
7.1 CHECK-UP FREQUENCY.....	19

1- INTRODUCTION

It is essential to read and follow the instructions and recommendations in this manual before operating **the pressurized hopper AURA-3215**. Careful reading enables maximum operator efficiency, prevents accidents and damage, and increases the performance's capacity and life expectancy.

Please ensure that this manual has been read by any person involved in performing **operational tasks**, (including preparation, dealing with mechanical problems and supervising the machine), **maintenance** (inspection and technical assistance) and **transport**.

For your safety, please follow these technical safety instructions as **SOLÀ** will not be responsible for damages caused by not observing the information provided.

In the first chapters you will find the Technical Characteristics and Safety Instructions. Basic concepts that are required to operate the machine are explained in the Starting, Adjusting and Maintenance sections.

The last part of this manual consists of Dosage Graphs.



MAQUINARIA AGRÍCOLA SOLÀ RESERVES THE RIGHT TO MODIFY ILLUSTRATIONS, TECHNICAL DATA AND TECHNICAL SPECIFICATIONS AT ITS DISCRETION.

2- SAFETY INSTRUCTIONS

2.1 SAFETY SYMBOLS

In this operating manual you will find three different symbols relating to safety:



TO WORK MORE EASILY WITH THE MACHINE.



TO PREVENT DAMAGE TO THE MACHINE AND OPTIONAL EQUIPMENT.



TO PREVENT PHYSICAL INJURY.

On the machine you will find the following warning pictograms:



Read the instructions carefully and observe the safety advice given in the operating manual.



During the coupling maneuver, stay away from the front part of the tractor. Check nobody stands in the operational area of the telescopic folding parts.
Risk of serious physical injury.



While maintaining or repairing the planter, stop the tractor's engine and prevent it from starting. The ignition key must be removed.



Risk of being crushed when working under the machine, please secure the machine to prevent this risk.
Risk of serious physical injuries.



It is forbidden to ride on the machine during operation. **Risk of serious physical injuries caused by falling.**



Danger of infection from escaping hydraulic fluid at high pressure! This can inflict serious injuries with potentially fatal consequences if it passes through the skin and into the body. **Keep the hose lines in good condition. Risk of serious physical injuries.**



Do not exceed maximum load.



Coupling point for loading and unloading the machine by crane. See section 2.3 LOADING AND UNLOADING INSTRUCTIONS.

2.2 GENERAL SAFETY REGULATIONS



- Before starting the machine, please check the machine is in good condition for work and is safe for road use.



- Check that visibility is clear around the machine and there is no person in the working area.



- In thoroughfare, please observe traffic signs and regulations.



- It is forbidden to ride on the machine or climb into the machine when it is running.



- Before using the machine, the user must be familiar with all operating elements.



- Please be extremely careful when coupling and uncoupling the machine to the tractor.



- Never leave the tractor's driver's seat while the machine is in operation.



- Do not deposit external elements inside the hopper.



- When maintaining the hydraulic system of the planter, make sure that it is depressurized and the tractor's engine is off.



- Please regularly check the condition of the tubes and hosepipes in the hydraulic system. These parts age naturally and their life should not surpass 6 YEARS. Please replace when necessary.



- During transit with the raised machine, block the lowering switch. Before leaving the tractor, lower the machine onto the ground and remove the tractor's starting key.



- Always use enough supporting elements when maintaining the machine in a raised position to prevent the machine from lowering or falling.



- Before starting to work a field, evaluate the risks coming from the terrain: pronounced slopes, possible contact with high-voltage overhead lines due to an uneven ground or due to the position of the movable or folding parts of the planter.



- Mount the group hydraulic multiplier only when the tractor's engine is off.

According with the working conditions defined by the final user and the options incorporated, the machines could not meet the requirements established by the law to transport them on public roads. The compliance of the law is strictly responsibility of the final user of the machine.

Maquinaria Agrícola Solá denies any responsibility derived of non-compliance of the regulations on the countries where their products are destined to.

2.4 LOADING AND UNLOADING INSTRUCTIONS



THESE OPERATIONS SHOULD BE PERFORMED ONLY BY QUALIFIED AND EXPERIENCED PERSONNEL.



WHEN THE MACHINE IS DELIVERED, IT SHOULD BE IMMEDIATELY CHECKED TO DETECT POSSIBLE DAMAGES DURING TRANSPORTATION OR MISSING PIECES. ONLY THE IMMEDIATE REPORTING OF THIS TO THE DELIVERER WILL RESULT IN COMPENSATION.



LOADING AND UNLOADING THE MACHINE MUST BE PERFORMED, IF POSSIBLE, USING A BRIDGE CRANE.

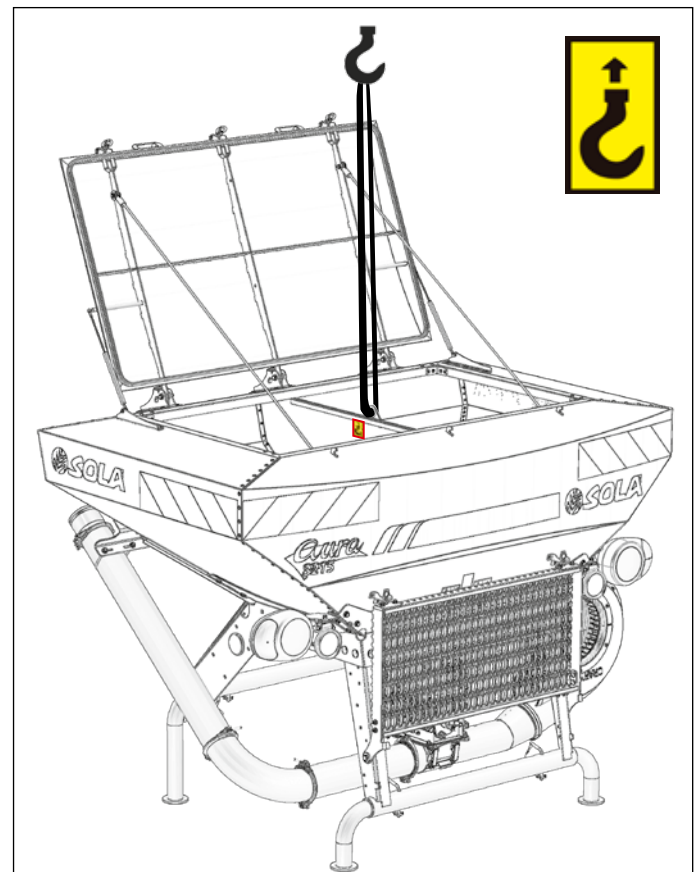

2.3 USE ACCORDING TO DESIGN

The **AURA-3215** front hopper has been specifically designed to be used as **FRONT DOSING HOPPER** for seeds or fertiliser.

The machine has been designed to work using an agricultural tractor with front lifting unity and three-point universal linkage.

If the machine is used in circumstances other than those specified above, the manufacturer will not be held responsible for any damage caused to persons or to the machine.

The user must observe all regulations concerning safety, traffic and hygiene.

If the machine is modified by the user, the manufacturer's warranty is cancelled. SOLÁ will not be held responsible for any damage caused to persons or to the machine.

The use of products with a high moisture content should be avoided since they can cause blockages.

3- GENERAL DESCRIPTION

3.1 GENERAL OVERVIEW

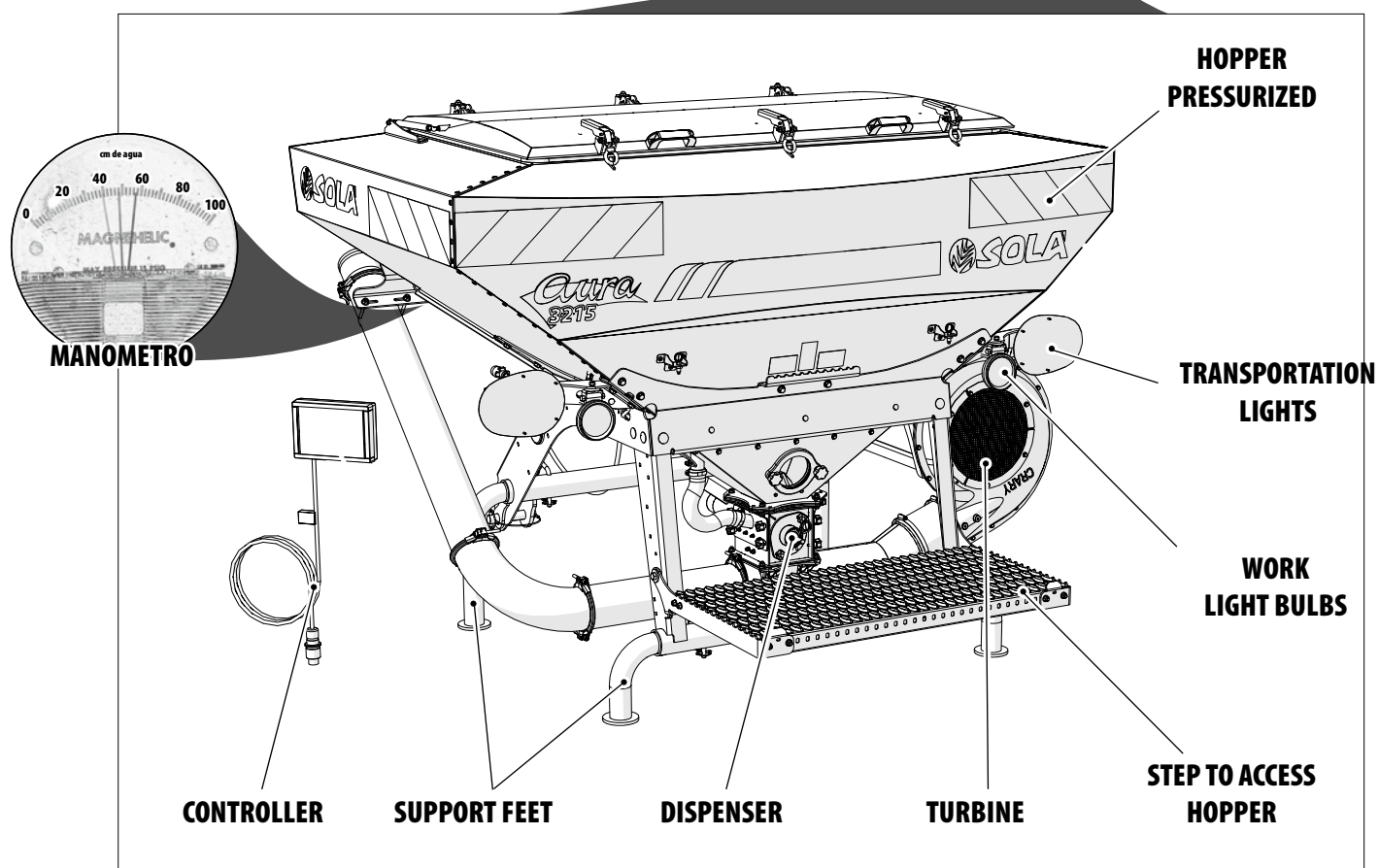
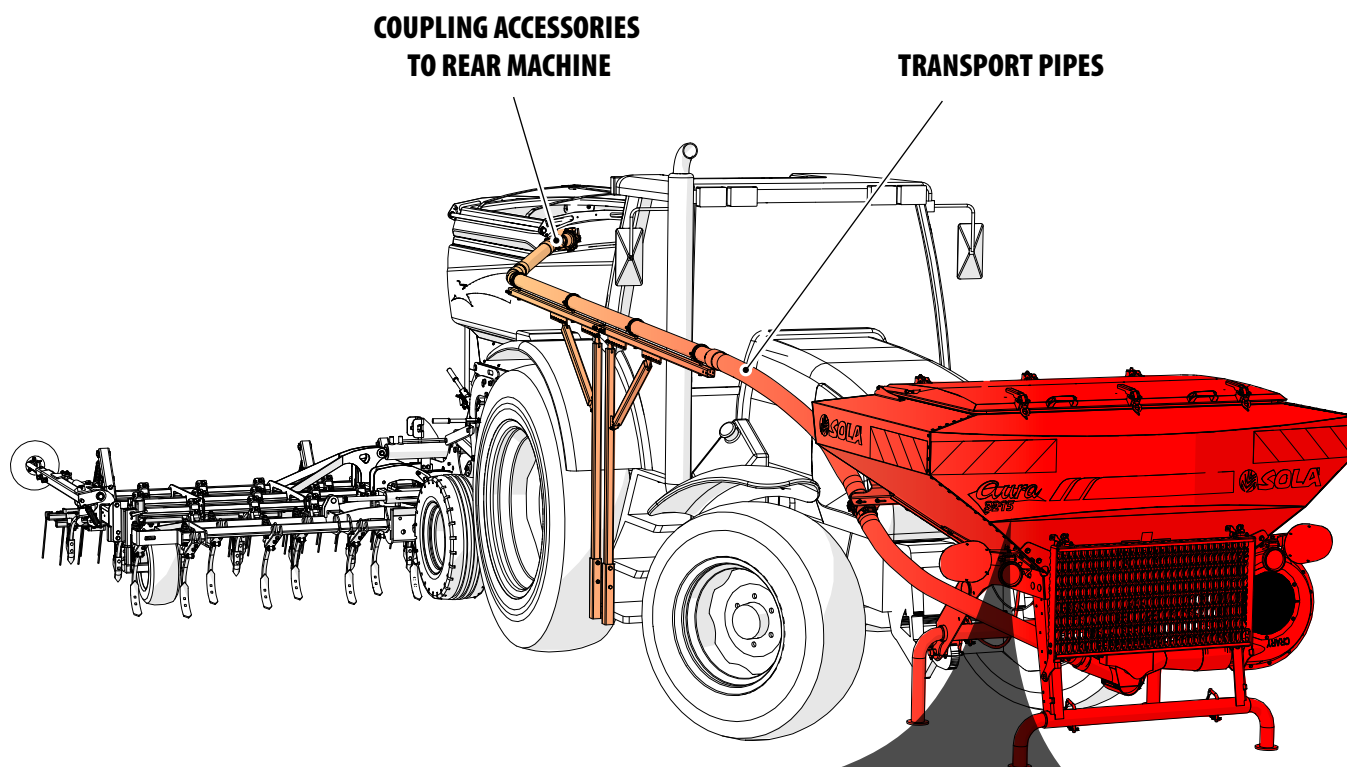

3.2 TECHNICAL FEATURES

FEATURES	MODEL 1.350	MODEL 2.000
Hopper capacity (L)	1.350	2.000
Empty weight (Tare Kg)	320	
Maximum Authorized Mass (M.M.A. Kg)	2.100	
Width (m)	2,10	2,30
Length (m)	1,36	1,73
Height (m)	1,82	1,90
Dimensions of the filler opening (m)	1,47 x 0,82	1,47 x 0,82
Category of the hitch	Cat. II	Cat. III

3.3 IDENTIFICATION OF THE MACHINE

All machines have an IDENTIFICATION PLATE at the three-points, which specifies:

- 1-** Manufacturer's name and address.
- 2-** Model number of the machine.
- 3-** Machine type.
- 4-** Serial number.
- 5-** CE Certificate and year manufactured (to last digits).

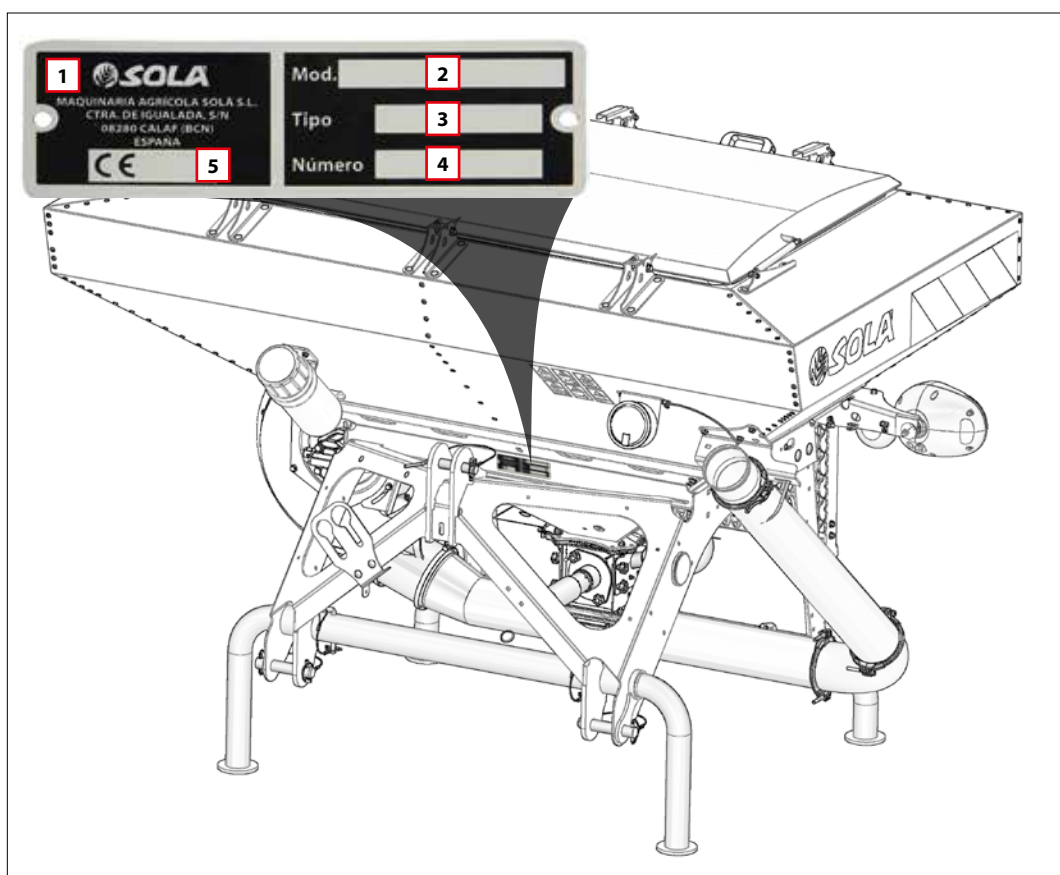

STARTING

4- STARTING

4.1 COUPLING THE MACHINE TO THE TRACTOR

The front hopper AURA-3215 is equipped with a three-point linkage of category 2.

To couple the hopper to the tractor, follow these steps:

- 1- Fix the three-point linkage to the tractor using 3 bolts.
- 2- Connect the hydraulic plugs to the turbine or if not feasible, connect the hydraulic multiplier group to the front power take-off.
- 3- Connect the 7 pin pineapple to the front electrical outlet of the tractor.
- 4- Installing the controller (as applicable):

A- ISOBUS:

- 1- Install and connect the cables from the front hopper up to the rear ISOBUS take. Turn the tractor's console on and download the program.

B- PERFORMER 530:

- 1- Install and connect the cables from the front hopper up to the controller in the tractor's cabin.
- 2- Install the switch in the rear duckfoot and connect to the controller.
- 3- Connect the 12 VCC take from the controller to the cabin's take.
- 4- Connect the cable of the speed sign from the tractor's cabin take or if applicable from the external radar.
- 5- Turn the controller on.

C- NON-APPLICABLE: for transfilling models.



IF THE CONTROLLER DOES NOT TURN-ON, CHECK THE CONNECTIONS.

- 5- Link the rear duckfoot with the specific accessories for the front hopper AURA-3215.
- 6- Install and connect the TRANSPORT TUBES from the front hopper up to the specific accessories of the rear duckfoot.
- 7- Lift up the front hopper and put the support feet in a working position.

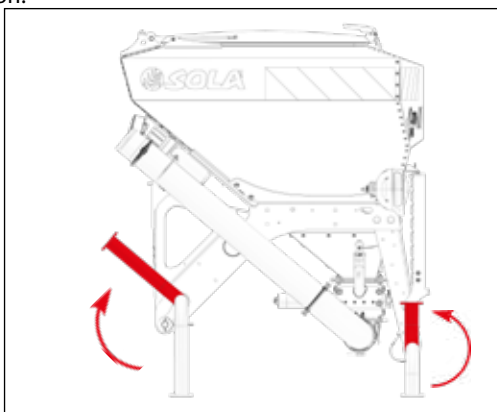

IF YOU DON'T FOLD THE SUPPORT FEET DURING TRANSPORTATION OR WORK OF THE FRONT HOPPER, IT MAY SUFFER DAMAGES.



DURING THE TRANSPORT OF THE MACHINE CLOSE THE CHOPPER TO PREVENT IT FROM COMPACTING THE MATERIAL IN THE METERING BOX.

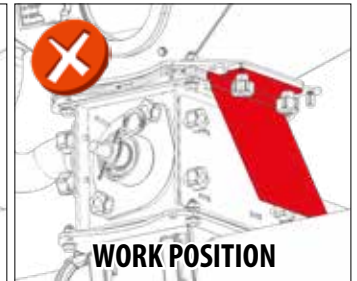
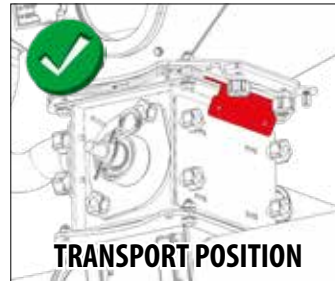

PREVIOUS VERIFICATION:

- 1- In working conditions (with the rear machine connected to the tractor and also to the front hopper and the hopper's top closed), make sure that the turbine spins and the pressure indicated by the pressure gauge is at least 40 cm of water.
- 2- Verify that the dispenser's engine spins constantly. Perform a TEST (refer to the controller's manual).

4.2 TRACTOR'S REQUIREMENTS

MACHINE COMPONENT	REQUIREMENTS TRACTOR
TURBINE	Hydraulic connection with 1/2" outlet and free 3/4" return or 540 rpm front power take-off
TRANSPORTATION LIGHTS AND WORK LIGHT BULBS	Front plug for 7 pin pineapple
Dispensers	A. ISOBUS Connection or 12 vcc connection to cabin (for dispensing) B. Front 12 vcc intake
THREE-POINT	FRONT THREE-POINT LINKAGE

Frame and scheme of the 7 pin connector:

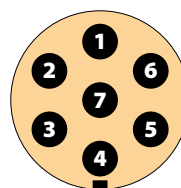

Pin Number	FUNCTION	Intensity (A)
1	Left intermittent	2
2	Short lights	6
3	Mass	-
4	Right intermittent	2
5	Position lights	1
6	Long lights	8
7	Work headlights	2,5

5- DOSAGE

5.1 DISPENSER TYPES

The machine may be configured with 3 types of dispensers:

- 1- ROLLING dispenser (for dosage or transfilling)
- 2- ENDLESS dispenser (only for dosage)
- 3- TRANSFILLING dispenser (only for transfilling)

In this subject, you will find symbols to distinguish the configurations required to dose or transfill a product to the rear duckfeet:



DOSAGE



TRANSVASE

5.1.1 ROLLING DISPENSER

Depending on the type of connection accessories installed in the rear duckfeet, this dispenser will be able to DOSE or TRANSFILL seeds or fertilizer.

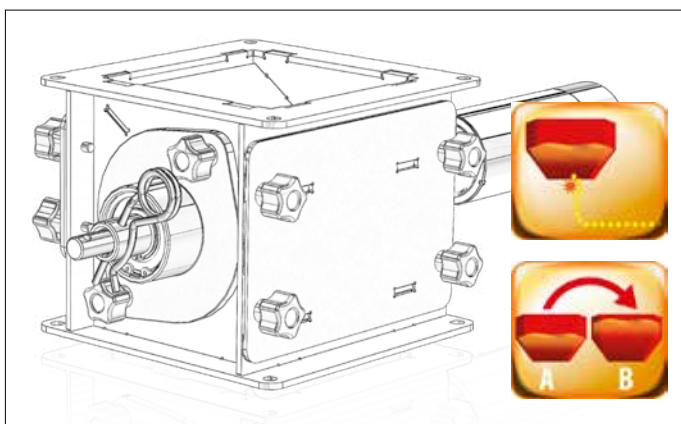

- The following configurations exist:
- A rolling dispenser with an outlet.
 - A rolling dispenser with two outlets.



IMPORTANT: DEPENDING ON THE WORK AND INSTALLATION CONDITIONS, THE DISPENSER SYSTEM IS CAPABLE OF WORKING UP TO 180 Kg/Ha WITH AN OUTLET OF Ø80, AND UP TO 250Kg/Ha WITH AN OUTLET OF Ø120 (WORK WIDTH CONSIDERED IS OF 6 METERS).



TO PERFORM SEED TRANSFILLING WITH THIS ROLLING DISPENSER, YOU MUST CONFIGURE IT WITH 7 SECTORS, IN WHICH CASE IT SHALL BE ABLE TO ACHIEVE VALUES CLOSE TO 42 Kg/min DEPENDING ON WORK AND INSTALLATION CONDITIONS.

This dispenser has a roller that may be configured in sectors. 1 to 7 sectors may be set-up.

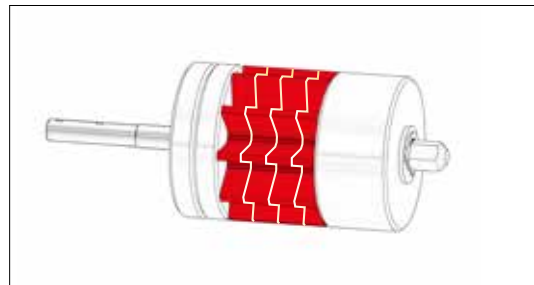

This dispenser should be configured and adapted to the desired dose, to achieve that follow the following steps:

- 1- See the dosage graphs to determine the number of rolling sectors required for the desired dose (refer to 5.3 DOSAGE GRAPHS).
- 2- Pull out latch "R".
- 3- Take the two screws out.

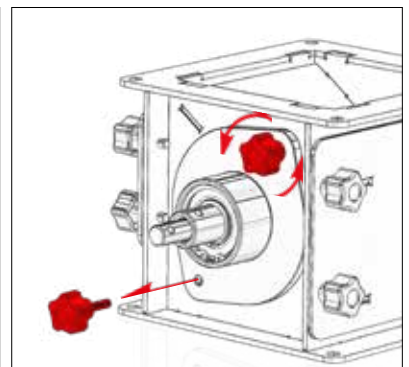
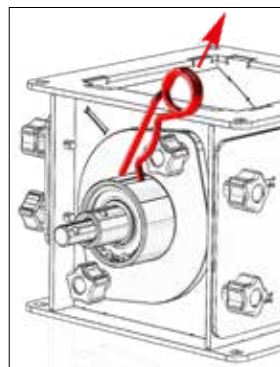

4- Pull out the side support and extract the roller.

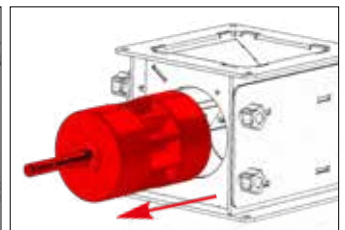
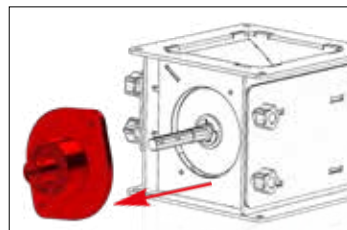

DOSAGE

5- Configure the number of sectors required depending on the desired dose, to modify the configuration of the sectors, the seeger ring must be pulled-out, set-up the sectors as per the dosage graph images and put the seeger ring back in place.

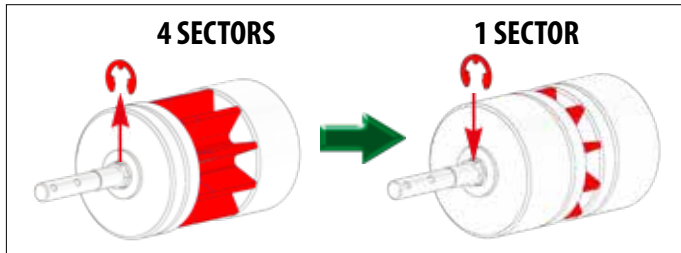

6- Reassemble the roller, side support and set in place with the two screws.



MAKE SURE THE SEEGER RINGS ARE WELL PLACED IN THEIR HOUSING, SO THAT THESE CAN BE TURNED AROUND.



WHEN EXTRACTING THE ROLLER, MAKE SURE NOT TO LOSE THE O-RINGS OF THE AXLE (SMALL) AND SIDE SUPPORT (BIG), PUT THE RINGS BACK TOGETHER CORRECTLY WHEN ASSEMBLING THE ROLLER.

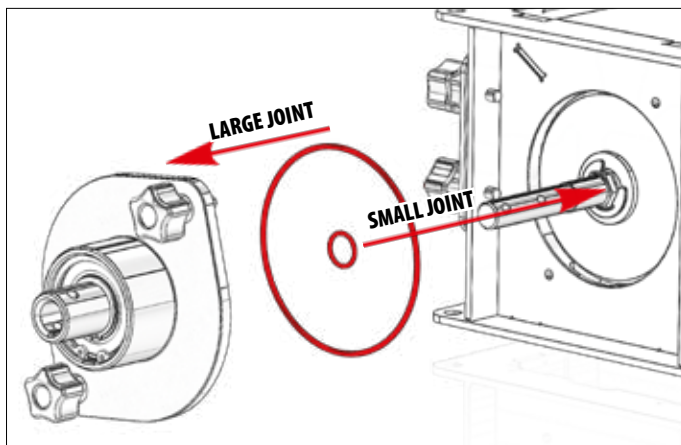

DON'T FORGET THE LATCH "R" OR THE DISPENSER WON'T WORK.

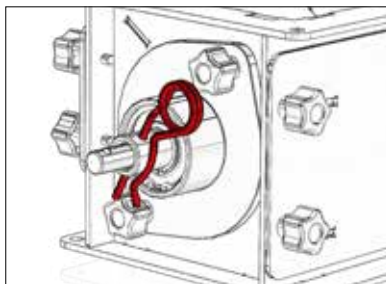

5.1.2 ENDLESS DISPENSER

This dispenser only works for DOSAGE of micro-granulated fertilizers in low doses.

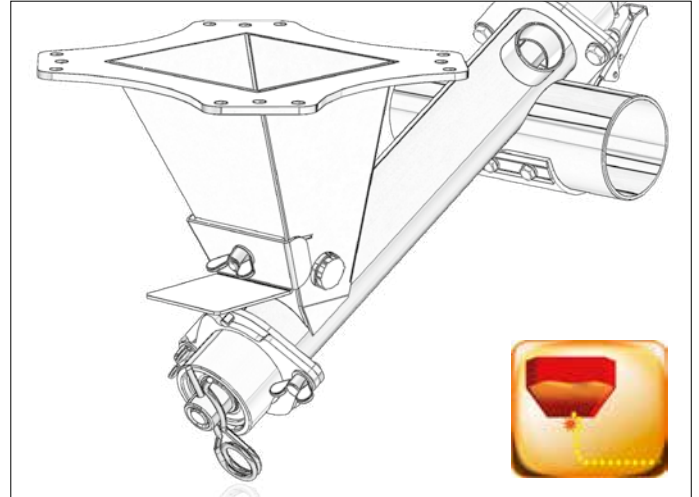

You may switch the endless of this dispenser to adapt it to the desired dose, and in order to do that follow the following steps:

- 1- See the following dosage graphs to determine the correct endless for the desired dose (refer to 5.3 DOSAGE GRAPHS).
- 2- Pull out latch "R".
- 3- Loosen the two locking handles.

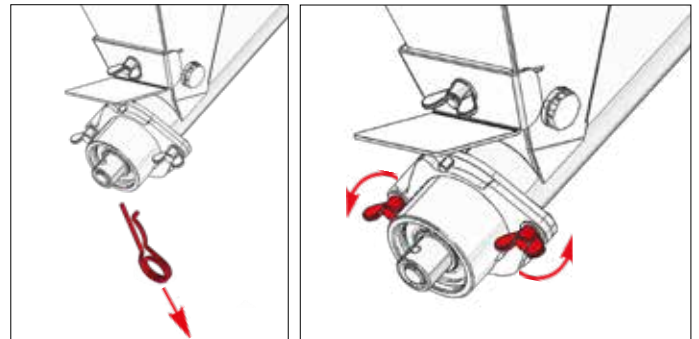

4- Pull out the lower support and extract the endless.

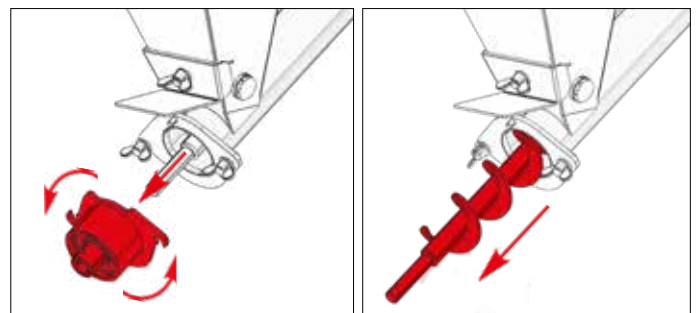

5- Mount the corresponding endless depending on the previously selected graph.



WHEN EXTRACTING THE ENDLESS, BE CAREFUL NOT TO LOSE THE O-RINGS OF THE AXLE. MOUNT THE O-RING CORRECTLY AFTER ASSEMBLING THE ENDLESS.

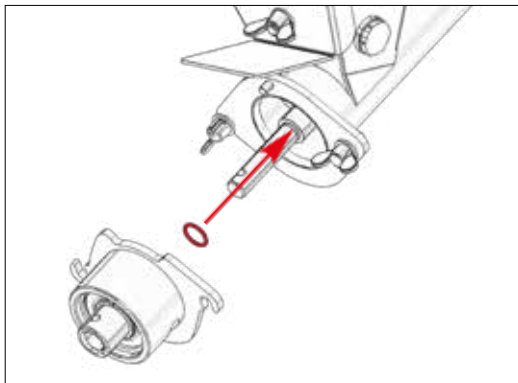

DON'T FORGET THE LATCH "R" OR THE DISPENSER WON'T WORK.

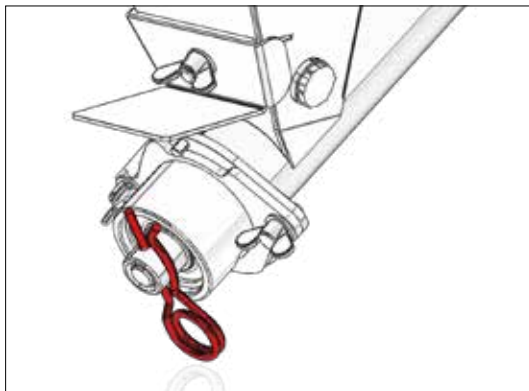

5.1.3 TRANSFILLING DISPENSER

This dispenser only works as TRANSFILLING of seed or fertilizer in low doses (20 Kg/min).

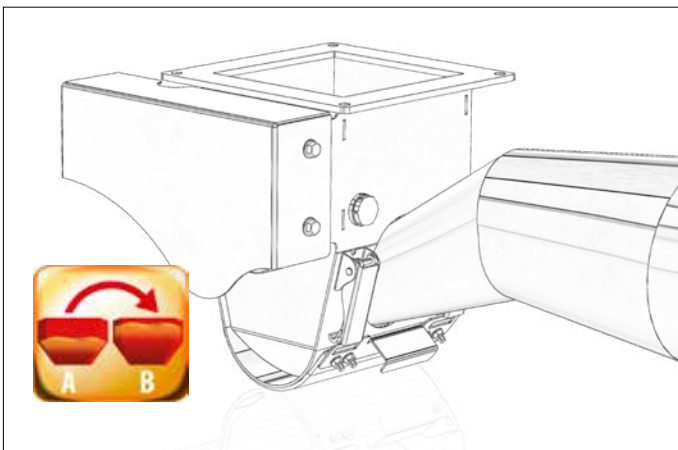

5.2 CALIBRATION TEST

Before working with the machine, a flow test must be performed in order to determine the dose to be distributed. For that, you must:

- 1- Assembly the distributor's roller or change the endless, in function of the chosen dosage graph.
- 2- Place the chopper in working position.

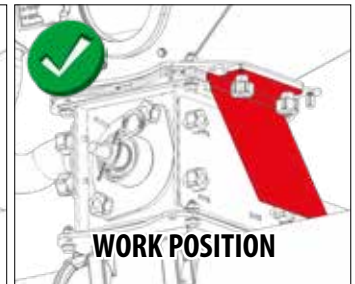
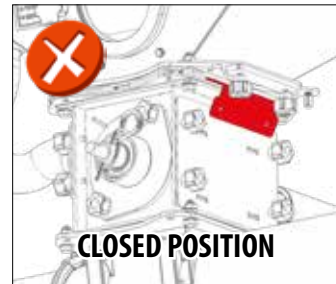

- 3- Open the calibration cap acting over the 2 closures.
- 4- Put the supplied sack or any other container below the calibration output.

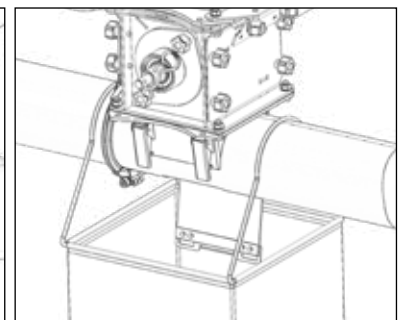
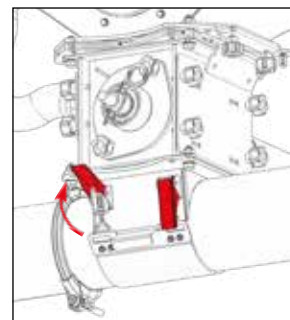

- 5- Act over the PERFORMER or ISOBUS controller of the machine to perform the test, see specific PERFORMER or ISOBUS manual.
- 6- Weigh the material in the sack or container and verify that it's the desired dose, if not increase or decrease the dose through the controller or by changing the number of sectors of the roller or endless (depending on the model).



WHENEVER THE DISTRIBUTOR'S CONFIGURATION IS MODIFIED OR PRODUCTS ARE SWITCHED, YOU MUST PERFORM A CALIBRATION TEST.



THE CONTROLLER'S SCREEN HAS A BAR THAT INDICATES THE ENGINE'S LOADING RANGE. IT MUST WORK WITHIN 60% TO 80% OF ITS CAPACITY.



WHEN FINISHING THE CALIBRATION TESTS, CLOSE THE CALIBRATION CAP AGAIN.

DOSAGE

5.3 DOSAGE GRAPHS

The dose per hectare that may be supplied by the dispenser depends on the number of sectors and type of endless. To find the dosage values you must:

- 1- Recalculate the value of the Kg/Ha in order to enter the graphs (value <X>), by using the following formula

$$X = K \times \frac{6}{A_{\text{LIGHT BULBS}}}$$

WHERE:

K = Kg/ha desired to dose.

A_{LIGHT BULBS} = Work width in meters.

X = Recalculated value in Kg/ha to enter the graphs.

- 2- With the recalculated value of the dose in Kg/Ha and the working speed in Km/h, enter it in the graphs where the intersection point is between the MAXIMUM and MINIMUM dosage curves.

EXAMPLE: For a rear machine with work width of **4,5 meters**, a desired dosage of **120 Kg/Ha** and a work speed of **8 Km/h**.

Step 1- Recalculate the dose <X>:

$$X = 120 \times \frac{6}{4,5} = 160 \text{ Kg/Ha}$$

Step 2- With the value of **160 Kg/Ha** and a work speed of **8 Km/h** enter the graphs:

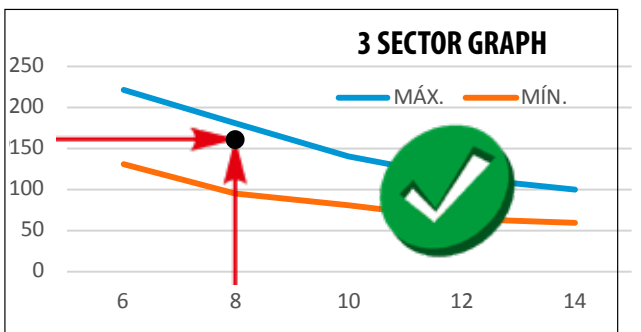
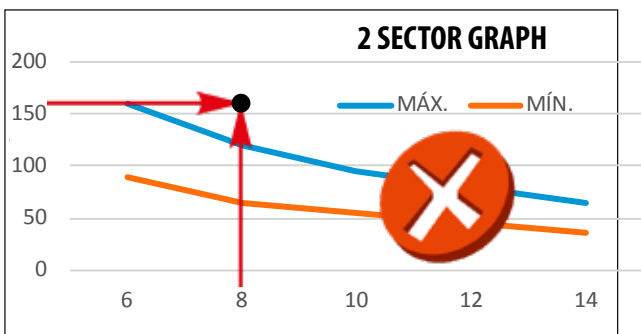

THE AMOUNTS INDICATED WITHIN THE GRAPHS MUST BE CONSIDERED AS ORIENTATION ESTIMATIONS AS THE PROVIDED FLOW MAY VARY DUE TO THE PRESENCE OF DUST, SIZE OF THE PRODUCT TO BE USED, DENSITY, HUMIDITY, ETC.



BEFORE STARTING TO WORK, PERFORM A TEST TO CALIBRATE IT. IN ORDER TO DO THAT, REFER TO THE CONTROLLER'S MANUAL FOR PERFORMER 530 OR IS-BUS (DEPENDING ON THE MODEL).



THE CONTROLLER'S SCREEN HAS A BAR THAT INDICATES THE ENGINE'S LOADING RANGE. IT MUST WORK WITHIN 60% TO 80% OF ITS CAPACITY.



THE DOSAGE GRAPHS ARE FOR MACHINES WITH A WORKING WIDTH OF 6 METERS FOR MACHINE MODELS WITH ROLLER DISTRIBUTORS AND ENDLESS.



DOSAGE GRAPHS CONSIDER A PRODUCT WITH DENSITY **1,056 Kg/L** FOR **FERTILIZER** WITH DISTRIBUTOR TO ROLLER TO BE APPLIED IN REAR MACHINE WITH DISTRIBUTOR HEAD **WITHOUT SEED LOAD**.



DOSAGE GRAPHS CONSIDER A PRODUCT WITH DENSITY **0,956 Kg/L** FOR **MICRO-GRANULATED FERTILIZER** WITH DISTRIBUTOR TO ENDLESS TO BE APPLIED IN REAR MACHINE WITH DISTRIBUTOR HEAD **WITHOUT SEED LOAD**.

5.3.1 ROLLER DISPENSER WITH A SINGLE OUTLET

5.3.1.1 ROLLER DISPENSER WITH A SINGLE OUTLET

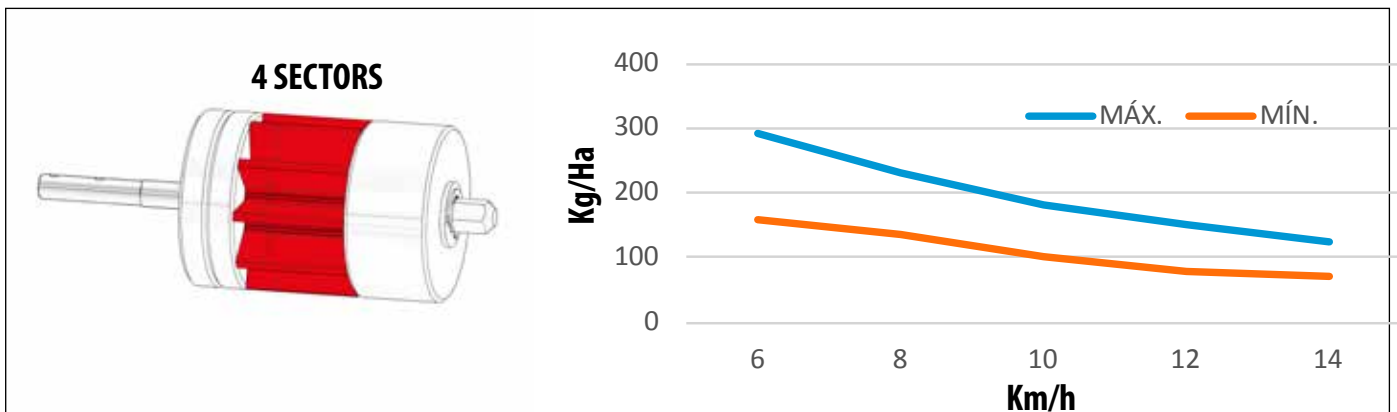
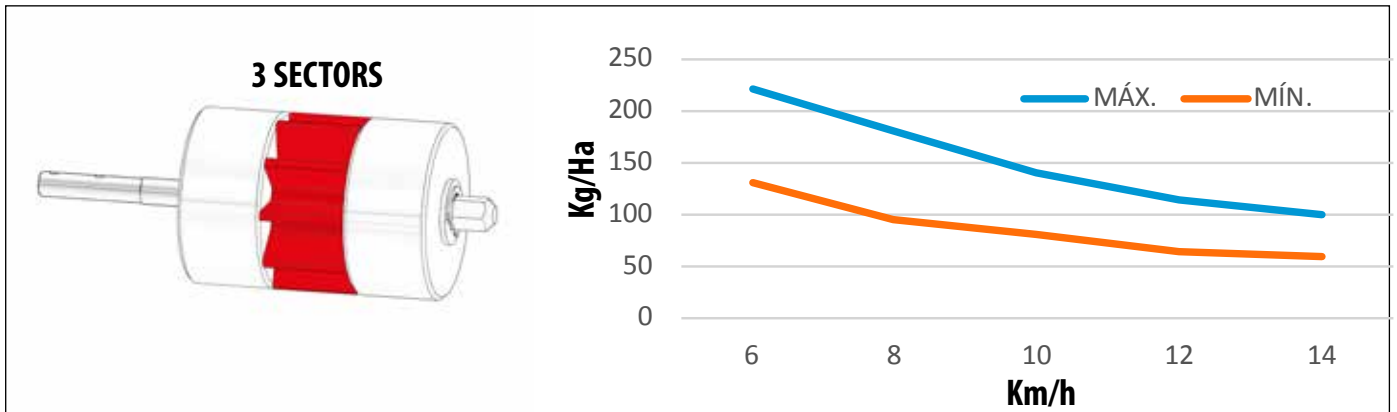
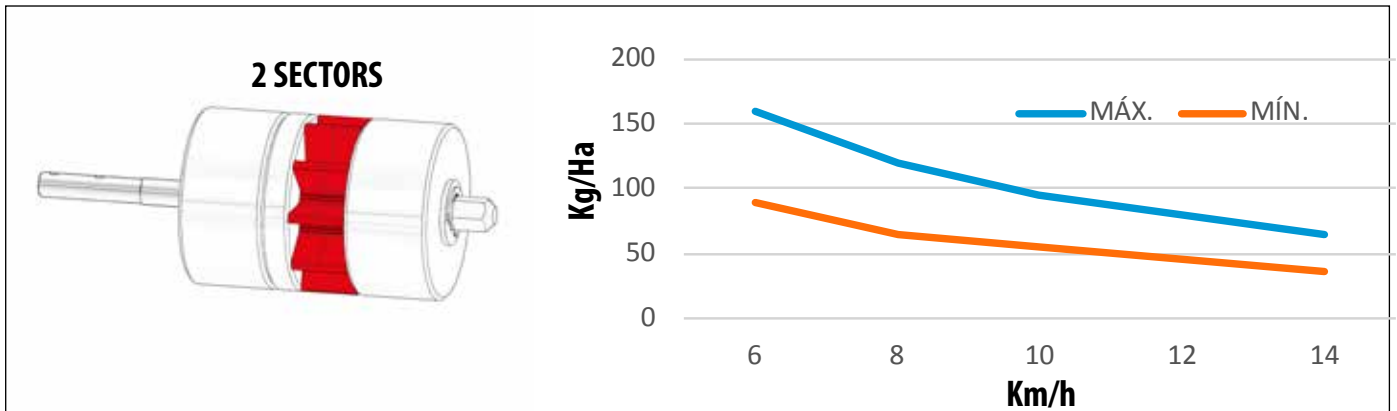
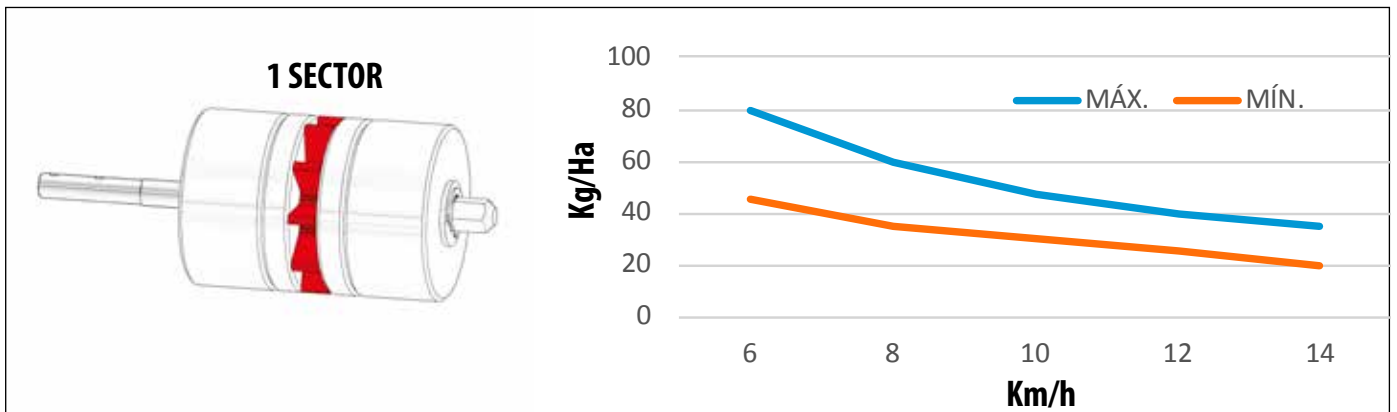

5.3.1.2 A ROLLER DISPENSER WITH TWO OUTLETS

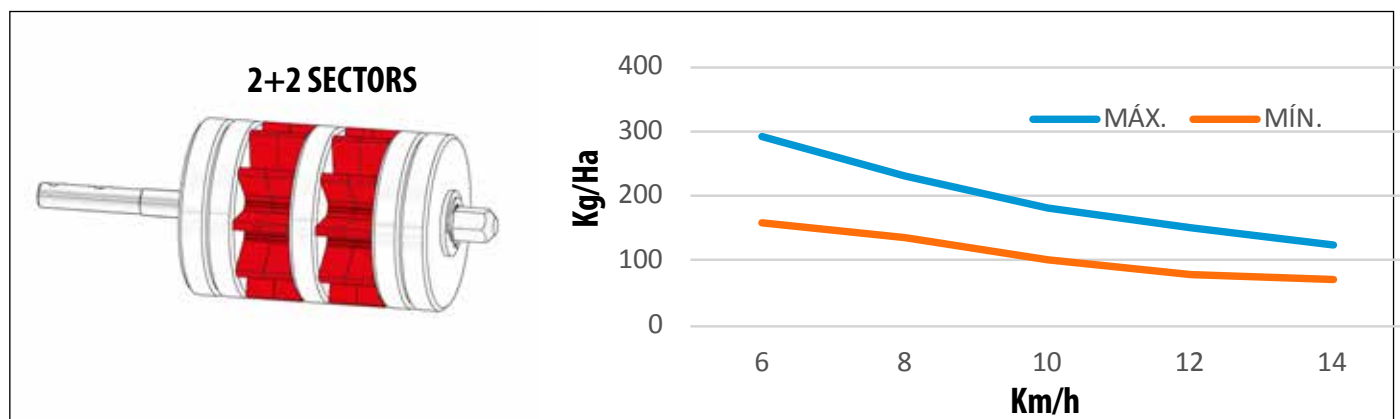
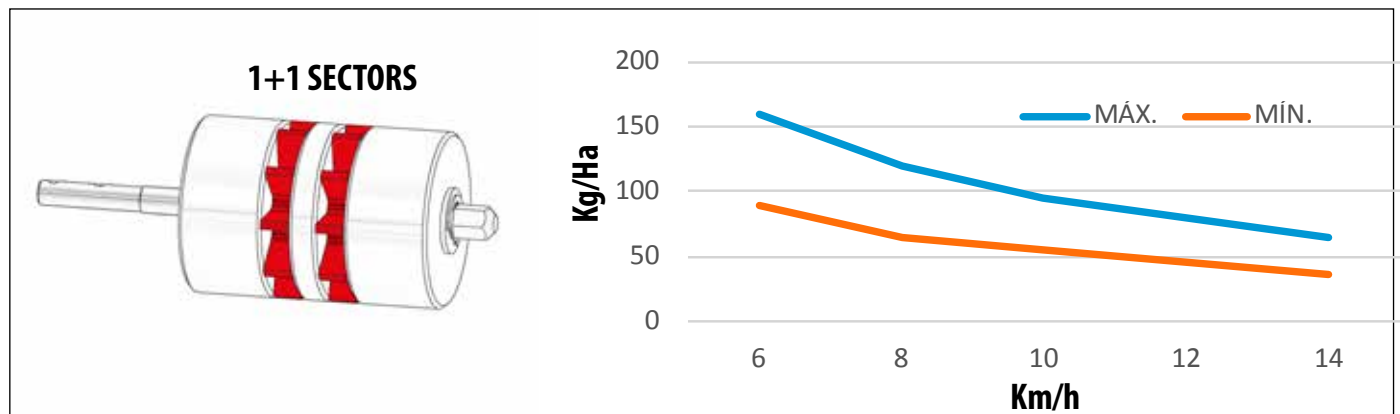

5.3.2 ENDLESS DISPENSER

5.3.2.1 AN ENDLESS DISPENSER WITH A SINGLE OUTLET

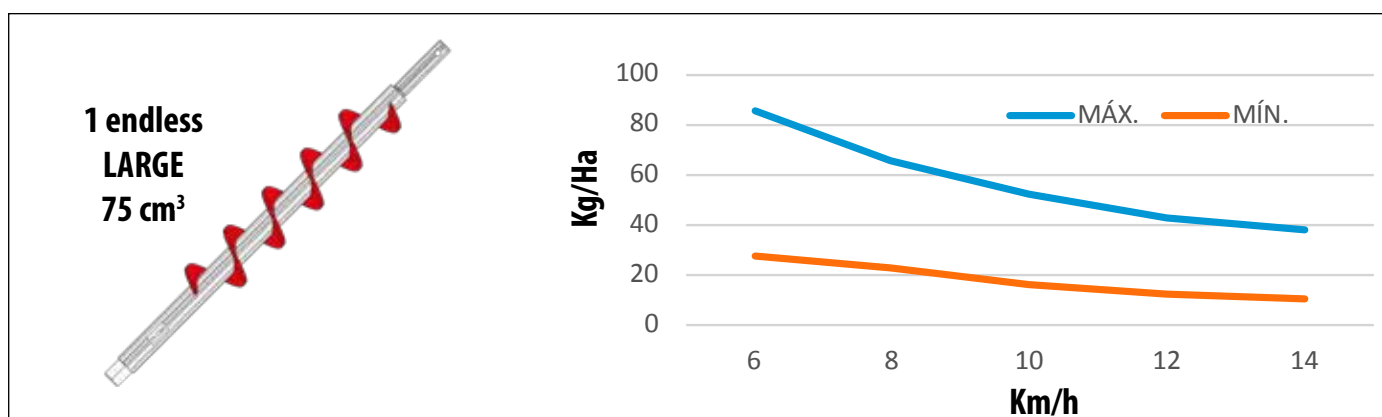
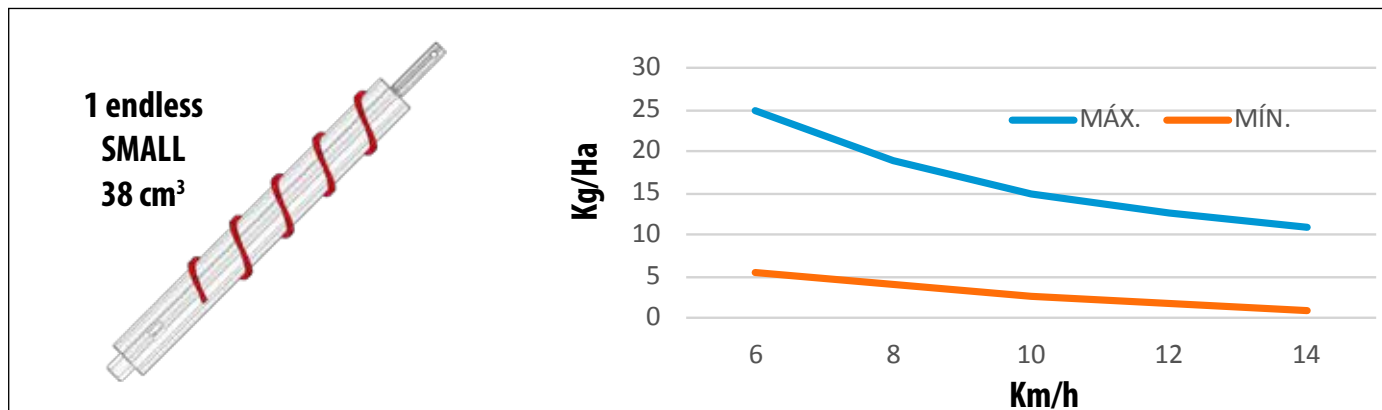

5.3.2.2 TWO ENDLESS DISPENSERS WITH TWO OUTLETS

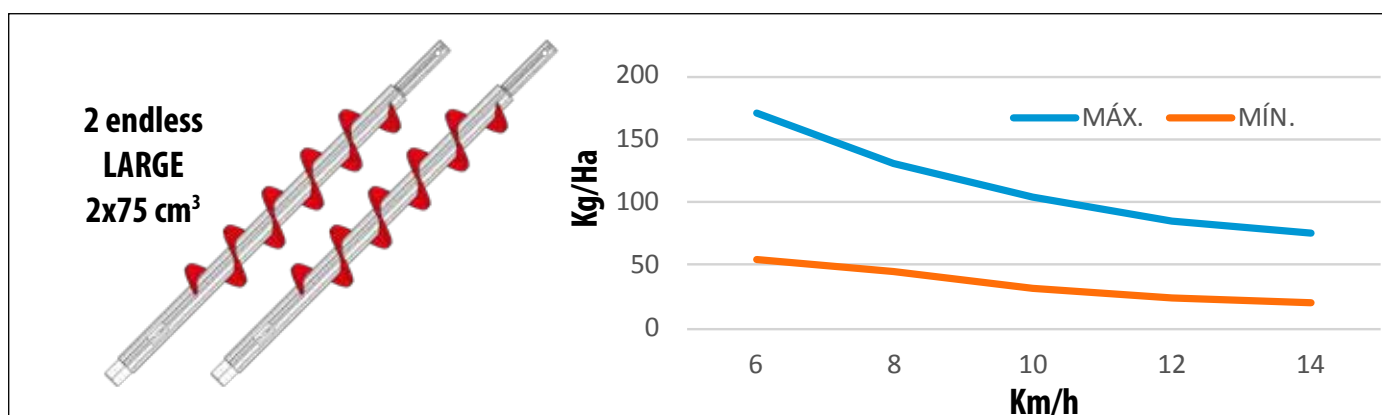
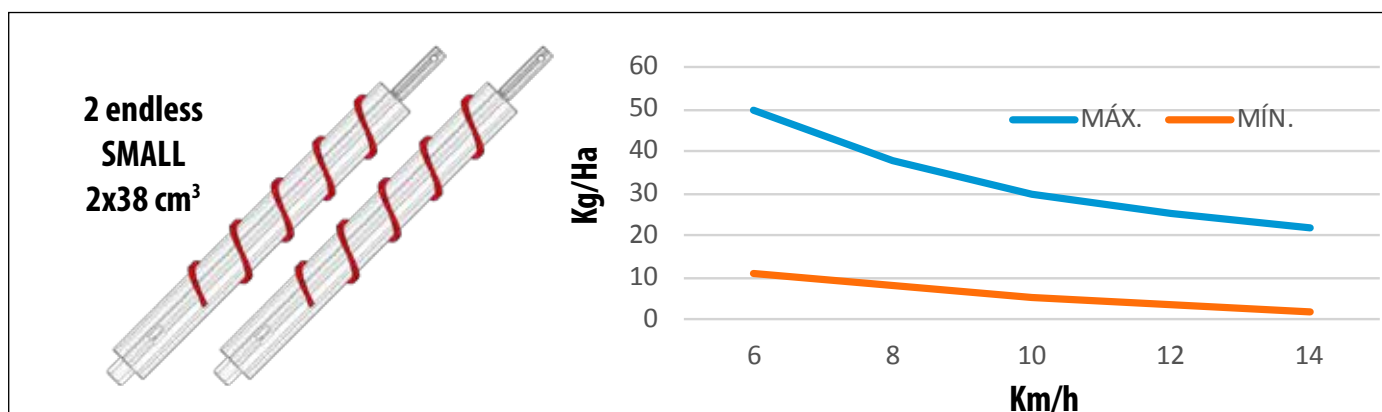

6-TIPS FOR USE

6.1 AURA-3215 WITHOUT ISOBUS

1- Forward speed:

To obtain a uniform work, keep the forward speed without sudden stops, since variations in forward speed modify the amount of product applied on the ground.

To put attention when starting and stopping the tractor:

- When **STARTING**, the air circuit is empty and the machine will not work until it has run some metres.
- When **STOPPING**, It is recommended to cut the dosing a few meters before stop.

2- Check product's flow:

Perform a previous calibration test in the warehouse in order to know exactly the amount of product going to be spread. Dosage is going to be very different when using different kinds of product, as it depends on factors such as density, moisture content, etc..

3- Distance between tramlines:

Keeping the distance between tramlines is essential to get optimal distribution.

6.2 AURA-3215 CON ISOBUS

1- Advancing speed:

Activate mode <PRESTART>. In this mode, dosage errors during start-up and shut-down of the tractor will be minimized. For that see specific manual for the MULTIPERFORMER ISOBUS.

7- MAINTENANCE



IN CASE OF MALFUNCTION, STOP THE PLANTER IMMEDIATELY AND REMOVE THE IGNITION KEY. LEAVE THE TRACTOR AND VISUALLY INSPECT AND EVALUATE THE EXTENT OF THE PROBLEM. PERFORM THE REQUIRED OPERATIONS ON THE PLANTER BEFORE RESTARTING IT.



MAINTENANCE OPERATIONS MUST BE PERFORMED IN PROPERLY EQUIPPED GARAGES BY QUALIFIED PERSONNEL.



NO REPAIRS SHOULD BE PERFORMED WITHOUT THE NECESSARY SKILLS AND KNOWLEDGE. IT IS ESSENTIAL THAT THE INSTRUCTIONS DETAILED IN THIS MANUAL ARE STRICTLY FOLLOWED. IF THESE INSTRUCTIONS ARE MISSING, PLEASE CONTACT THE PLANTER'S PROVIDER OR QUALIFIED PERSONNEL.



IN ORDER TO PERFORM MAINTENANCE OR REPAIR OPERATIONS TO THE PLANTER, IT IS ESSENTIAL TO USE PROPER **PERSONAL PROTECTIVE EQUIPMENT (PPE)**: SAFETY BOOTS AND GLOVES, HEARING PROTECTION, DUST MASK AND PROTECTIVE GLASSES).



IT IS RECOMMENDED TO AVOID WEARING LOOSE CLOTHING SINCE IT MAY BECOME TANGLED WITH THE PLANTER'S MOVING PARTS.

Before performing any task on the machine, it is essential to take into account the following factors:

- Maintaining or repairing the planter should be performed on a flat and compact ground. Before starting any of these tasks, the tractor's engine must be turned off and the ignition key removed.
- The chosen device to raise the planter needs to be appropriate for the operations to be performed. Please ensure that all safety regulations are observed.
- Always use appropriate protective equipment for any task to be performed.
- In case compressed air is used to clean the planter, you are required to wear protective glasses and mask.
- If any operation needs to be performed on a part of the machine which is at more than 1,5 metres height from the ground, check if it is possible to reach this part using the planter's access points. If not possible, use either a ladder or a platform which is in accordance with the current safety regulations.
- Prolonged and/or repetitive skin contact with fuel and lubricants is harmful. In case these products come accidentally into contact with the eyes or other sensitive parts, wash well the affected parts with clean water. In case of ingestion, contact the medical services immediately.

7.1 CHECKING FREQUENCY

The periodicity of the check-ups indicated below is solely for orientation purposes. It may suffer variations depending on the type of service, use of the machine and conditions of use.

- BEFORE STARTING THE SOWING SEASON:

Check the general operation of the planter. Perform this check without any products inside the hopper.

Check that the plastic components of the planter are in good condition. The wear of this material due to natural ageing or to the presence of rodents causes damages to these components.

Check that the mechanical components are in good condition and not rusty.

Clean the parts of the machine which are permanently in contact with seeds or fertilizers, such as hopper and metering unit.

Check that the signal lamps work properly.

Check that the unions and the ducts of the hydraulic system do not show oil leaks.

- DAILY:

Empty and clean with air pressure both the hopper and the dispenser of residual products that may remain after finishing the work shift.

Check that the metering unit and the air circuit do not contain any residue (such as seed or fertilizer residue, dust, etc). Residue accumulation may damage the air circuit.

- END OF SOWING SEASON

Empty and clean with air pressure both the hopper and the dispenser, making sure that there are no residual products,

If washing the machine, make sure no residual products remain, as they may damage the machine if left to dry.

Repaint any metallic component which has lost its paint due to wear. To store the planter properly, cover it with tarpaulin and keep it in a dry place.

Thoroughly check all components of the planter and replace the ones which are damaged or worn.

A careful maintenance of the machine ensures proper functioning and long service life of the machine.



BEFORE PERFORMING THESE OPERATIONS, THE PLANTER'S ENGINE MUST BE TURNED OFF AND THE IGNITION KEY REMOVED.

The next table shows the maintenance operations to be performed on the machine along with their (GUIDANCE) frequency:



AFTER THE FIRST 10 HOURS OF WORK, TIGHTEN THE SCREWS.

MAINTENANCE

INTERVENTION AREA	OPERATION TO BE PERFORMED	DAILY	WEEKLY	ANNUAL
Road lights and signs	Check light conditions and functioning	•		
	Make sure that the safety adhesives are in place and readable		•	
Hydraulic components	Check the condition of the hoses and hydraulic connectors, make sure there are no leaks		•	
	Check the oil filter status (only for turbines with an independent hydraulic circuit)		•	
Pneumatic system	Clean the dirt from the turbine's protective grille and check its condition	•		
	Check the condition of the spinning state of the turbine		•	
	Check the condition of the pipes and replace those that have cracks		•	
Rubber components and plastic pieces	Check its deterioration and if required replace the damaged components			•
Screws	Check the condition of the screws. Tighten all screws and bolts		•	
Endless dispenser	Clean the dispenser, don't leave any residual material	•		
Roller dispenser	Clean and check the status of the roller and sealing lip, don't leave any residual material	•		

